

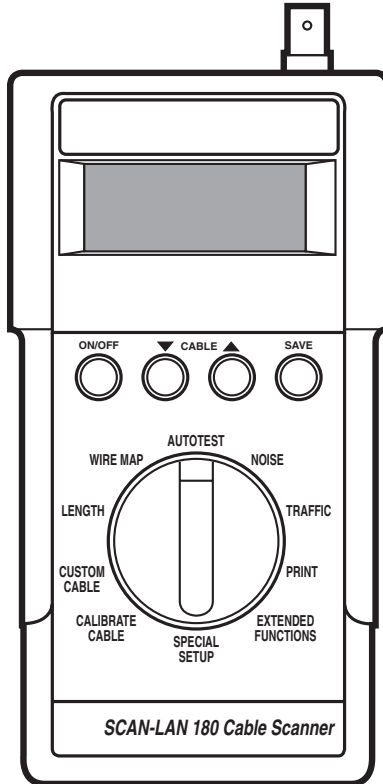

SCAN-LAN 180 Cable Scanner

SL 180 Token Ring Kit



**CUSTOMER
SUPPORT
INFORMATION**

Order toll-free in the U.S.: Call **877-877-BBOX** (outside U.S. call **724-746-5500**)
FREE technical support 24 hours a day, 7 days a week: Call **724-746-5500** or fax **724-746-0746**
Mailing address: **Black Box Corporation**, 1000 Park Drive, Lawrence, PA 15055-1018
Web site: www.blackbox.com • E-mail: info@blackbox.com

**FEDERAL COMMUNICATIONS COMMISSION
AND
INDUSTRY CANADA
RADIO FREQUENCY INTERFERENCE STATEMENTS**

This equipment generates, uses, and can radiate radio frequency energy and if not installed and used properly, that is, in strict accordance with the manufacturer's instructions, may cause interference to radio communication. It has been tested and found to comply with the limits for a Class A computing device in accordance with the specifications in Subpart J of Part 15 of FCC rules, which are designed to provide reasonable protection against such interference when the equipment is operated in a commercial environment. Operation of this equipment in a residential area is likely to cause interference, in which case the user at his own expense will be required to take whatever measures may be necessary to correct the interference.

Changes or modifications not expressly approved by the party responsible for compliance could void the user's authority to operate the equipment.

This digital apparatus does not exceed the Class A limits for radio noise emission from digital apparatus set out in the Radio Interference Regulation of Industry Canada.

Le présent appareil numérique n'émet pas de bruits radioélectriques dépassant les limites applicables aux appareils numériques de la classe A prescrites dans le Règlement sur le brouillage radioélectrique publié par Industrie Canada.

**NORMAS OFICIALES MEXICANAS (NOM)
ELECTRICAL SAFETY STATEMENT**

INSTRUCCIONES DE SEGURIDAD

1. Todas las instrucciones de seguridad y operación deberán ser leídas antes de que el aparato eléctrico sea operado.
2. Las instrucciones de seguridad y operación deberán ser guardadas para referencia futura.
3. Todas las advertencias en el aparato eléctrico y en sus instrucciones de operación deben ser respetadas.
4. Todas las instrucciones de operación y uso deben ser seguidas.
5. El aparato eléctrico no deberá ser usado cerca del agua—por ejemplo, cerca de la tina de baño, lavabo, sótano mojado o cerca de una alberca, etc..
6. El aparato eléctrico debe ser usado únicamente con carritos o pedestales que sean recomendados por el fabricante.
7. El aparato eléctrico debe ser montado a la pared o al techo sólo como sea recomendado por el fabricante.
8. Servicio—El usuario no debe intentar dar servicio al equipo eléctrico más allá a lo descrito en las instrucciones de operación. Todo otro servicio deberá ser referido a personal de servicio calificado.
9. El aparato eléctrico debe ser situado de tal manera que su posición no interfiera su uso. La colocación del aparato eléctrico sobre una cama, sofá, alfombra o superficie similar puede bloquea la ventilación, no se debe colocar en libreros o gabinetes que impidan el flujo de aire por los orificios de ventilación.
10. El equipo eléctrico deber ser situado fuera del alcance de fuentes de calor como radiadores, registros de calor, estufas u otros aparatos (incluyendo amplificadores) que producen calor.
11. El aparato eléctrico deberá ser conectado a una fuente de poder sólo del tipo descrito en el instructivo de operación, o como se indique en el aparato.

12. Precaución debe ser tomada de tal manera que la tierra física y la polarización del equipo no sea eliminada.
13. Los cables de la fuente de poder deben ser guiados de tal manera que no sean pisados ni pellizcados por objetos colocados sobre o contra ellos, poniendo particular atención a los contactos y receptáculos donde salen del aparato.
14. El equipo eléctrico debe ser limpiado únicamente de acuerdo a las recomendaciones del fabricante.
15. En caso de existir, una antena externa deberá ser localizada lejos de las líneas de energía.
16. El cable de corriente deberá ser desconectado del cuando el equipo no sea usado por un largo periodo de tiempo.
17. Cuidado debe ser tomado de tal manera que objetos líquidos no sean derramados sobre la cubierta u orificios de ventilación.
18. Servicio por personal calificado deberá ser provisto cuando:
 - A: El cable de poder o el contacto ha sido dañado; u
 - B: Objetos han caído o líquido ha sido derramado dentro del aparato; o
 - C: El aparato ha sido expuesto a la lluvia; o
 - D: El aparato parece no operar normalmente o muestra un cambio en su desempeño; o
 - E: El aparato ha sido tirado o su cubierta ha sido dañada.

Contents

Chapter	Page
1.0 Specifications	6
2.0 Introduction	6
2.1 Features/Functions	6
2.2 Testing Twisted-Pair Networks—IEEE and EIA/TIA 568	6
2.2.1 IEEE Tests	8
2.2.2 EIA/TIA 568 Tests	8
2.3 Controls	9
2.4 Connectors	11
2.5 Remote Unit	12
3.0 Cable Tests	13
3.1 Autotest	13
3.1.1 Cable Type Selection	13
3.1.2 Testing Twisted-Pair Cables	13
3.1.3 Testing Coax Cables	24
3.1.4 Checking Multiple Cables	29
3.2 Individual Cable Tests	30
3.2.1 Wire Map (Twisted-Pair Cables Only)	30
3.2.2 Length Test	31
3.2.3 Noise Test	33
4.0 Traffic Measurement	35
4.1 Traffic Test	35
4.2 Printing Traffic Reports	37
5.0 Printing Test Reports	40
6.0 Oscilloscope Scan	46
6.1 UTP Cables	46
6.2 Coax Cables	50
7.0 Cable Calibration	54
8.0 Custom Cable Types	56

Chapter	Page
9.0 Special Setup.....	59
9.1 Units of Length.....	59
9.2 Audible Tone.....	59
9.3 Circuit Identifiers.....	60
9.4 Fault Threshold.....	61
9.5 Noise Threshold.....	62
9.6 Saving/Resetting Changes.....	62
9.7 Resetting the Scanner to Factory Settings.....	63
10.0 Maintenance.....	65
10.1 Self-Test.....	65
10.2 Power.....	67
10.2.1 SCAN-LAN 180 Cable Scanner.....	67
10.2.2 Remote Unit.....	67
Appendix A: Standard Cable Types.....	68
Appendix B: Cable Test Pass/Fail Limits.....	70
B.1 Twisted-Pair Cables.....	71
B.1.1 IEEE Test Limits.....	71
B.1.2 EIA/TIA 568 Test Limits.....	74
B.2 Coaxial Cables.....	78
Appendix C: Pinouts.....	81
C.1 Printer Connector.....	81
C.2 Serial Printer Cable.....	82
C.3 RJ-45 Clip-Lead Cable.....	82
Appendix D: Glossary.....	84
Index.....	90

TRADEMARKS

IBM® and AT® are registered trademarks of International Business Machines Corporation.

ARCNET® is a registered trademark of Datapoint Corporation.

Any other trademarks mentioned in this manual are acknowledged to be the property of the trademark owners.

1.0 Specifications

Display — 4 line LCD with 16 characters per line

Keys — (4) ON/OFF; ▲, ▼ for menu scrolling; SAVE

Function Select — 10 position rotary switch

Power — (2) 9-V alkaline batteries, 115 or 130 VAC (9 VDC, 300 mA) adapter

Size — 1.7"H x 4"W x 7.6"D (4.3 x 10.2 x 19.3 cm)

Weight — 1.2 lb. (0.5 kg)

2.0 Introduction

The SCAN-LAN 180 Cable Scanner is an easy to use, handheld tester for qualifying and troubleshooting coax and twisted pair local area network (LAN) cable installations.

Via Autotest, the Scanner measures critical performance characteristics of LAN cable installations, compares the results against IEEE LAN specifications, and gives a simple PASS/FAIL indication. The measurements are also compared against EIA/TIA 568 specifications with warnings for cables that fail to meet the specifications.

Up to 500 cable test results may be stored in the Scanner. The Scanner includes a printer port to allow you to print hardcopy results.

The Scanner may also monitor live network performance for Ethernet networks.

2.1 Features/Functions

- Cable length—using time domain reflectometry (TDR), the Scanner measures the length of the cable and displays up to three fault anomalies.
- NEXT—the Scanner measures near-end crosstalk (NEXT) on twisted-pair networks between 5 and 20 MHz.
- Attenuation—the Scanner measures cable attenuation on twisted-pair networks between 5 and 20 MHz.
- Wire Map—the Scanner tests that the cable is wired correctly for the selected network.
- Traffic monitoring—the Scanner displays the continuous percentage of use along with a bar-graph display of network activity.
- Printed reports—the Scanner can store up to 500 cable tests and one traffic test for printing.

2.2 Testing Twisted Pair Networks—IEEE and EIA/TIA 568

Increasingly, Unshielded Twisted Pair cabling (UTP) is being installed in LANs. There are presently two standards that specify the necessary performance of the twisted-pair cabling in LAN environments: (1) the specifications, developed by the Institute of Electrical and Electronics Engineers, collectively known as 802.3 and 802.5, and (2) the specifications, recently developed by the Electrical Industry Association and Telecommunications Industry Associations, known as EIA/TIA 568. The Autotest function of the Scanner measures important parameters of twisted

pair cabling such as cable length, NEXT, and attenuation and compares the readings against both specifications.

2.2.1 IEEE TESTS

The screen presented at the conclusion of the Scanner Autotest function indicates the results of comparing the cable length, attenuation, and NEXT against the applicable IEEE 802 specifications. Readings that fail to meet the IEEE specifications flash in the Autotest Results screen.

Pass	30'
NEXT:	26 dB
Attenuation:	3 dB
OK for 10BASE-T	

Fig. 2-1. Autotest Results Screen.

2.2.2 EIA/TIA 568 TESTS

The EIA/TIA 568 specifications recognize the categories of UTP cables for LAN environments shown in Table 2-1.

Table 2-1. Categories of UTP Cables for LAN Environments.

Cable Category	LAN Speeds Supported
category 3	Up to 10 Mbps (10BASE-T, 4-Mbps Token Ring)
category 4	Up to 16 Mbps (10BASE-T, 4/16-Mbps Token Ring)
category 5	Up to 100 Mbps (10BASE-T, 4/16-Mbps Token Ring, CDDI)

UTP cabling installed according to the wiring practices documented in EIA/TIA 568 that meet the transmission requirements for Category 4 cabling will support 10BASE-T and 4/16-Mbps Token Ring networks.

The Autotest function of the Scanner compares the measured cable attenuation and near-end crosstalk against EIA/TIA 568 standards based on the cable category selected. For example, if the cable type “10BASE-T Cat 4” has been selected, the Autotest function will compare the measured Attenuation and NEXT against EIA/TIA 568 Category 4 specifications.

If excessive attenuation or NEXT are measured when compared to the EIA/TIA 568 specifications, an EIA 568 Warning screen will be displayed.

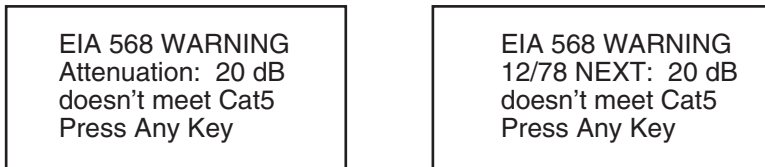

Fig. 2-2. EIA 568 Warning Screens.

2.3 Controls

The Scanner is operated with a rotary function selector and four pushbutton switches.

- Rotary Function Selector—selects the operating mode: Autotest, Special Setup, Noise, Calibrate Cable, Traffic, Custom Cable, Print, Length, Extended Functions, Wire Map.
- ON/OFF Button—turns the power to the Scanner on or off. When no activity has been detected for five minutes, the Scanner will automatically power down to conserve battery power.

SCAN-LAN 180 CABLE SCANNER

- ▼ ▲ Buttons—select the cable type from a list of preset and user-defined types. Also used to scroll through a list of selections.
- SAVE Button—saves test results in the Scanner's memory; also used to confirm choices.

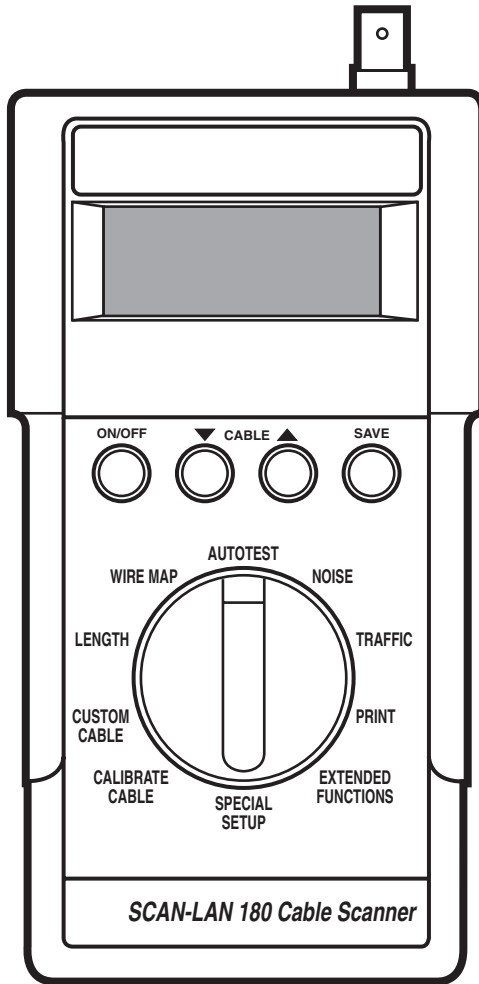

Fig. 2-3. SCAN-LAN 180 Cable Scanner.

2.4 Connectors

There are four connectors on the Scanner:

- BNC—shielded connector for coax cable.
- RJ-45—standard 8-pin modular jack for twisted-pair cable.
- PRINTER—DB9 male connector to interface to a printer via the standard IBM® AT® RS-232 serial printer cable included with the Scanner.
- 9 VDC 300 mA—power connector for the wall plug-in power supply that is included with the Scanner.

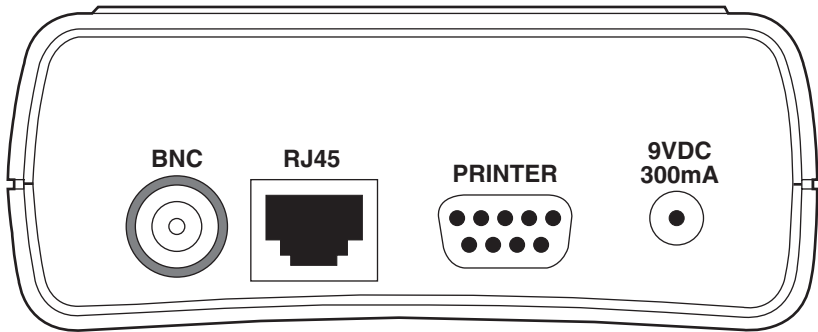

Fig. 2-4. Connectors on the Scanner.

2.5 Remote Unit

The Remote Unit is connected at the far end of the cable when using Autotest to test twisted-pair cable. The Remote Unit, when used with the Scanner, permits NEXT and attenuation measurements and allows connector wiring to be mapped. Power is supplied by a single 9-volt battery.

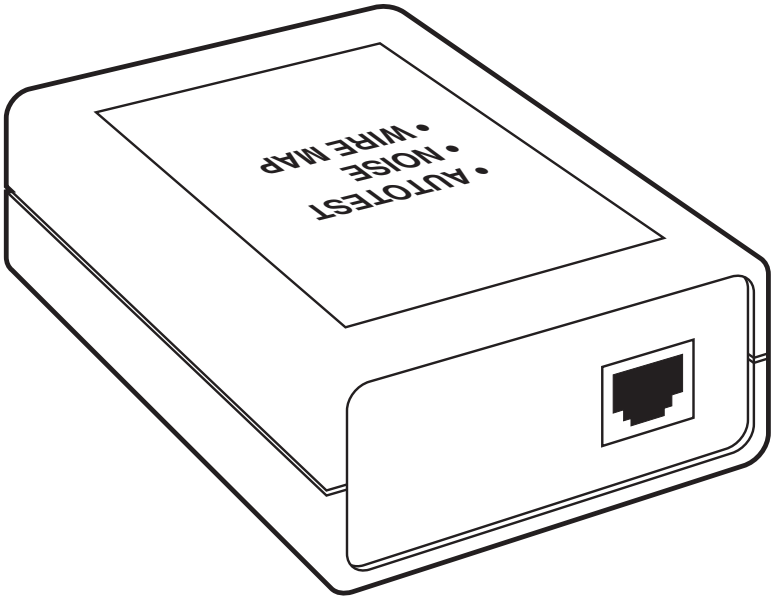

Fig. 2-5. Remote Unit.

3.0 Cable Tests

3.1 Autotest

The Autotest function will be the mode you will use most frequently when testing LAN cabling. Included with Autotest are all the necessary tests to qualify the cable type you have selected. Simply select Autotest mode, set the cable type, and plug in the cable to be tested. Any problems encountered will be reported on the Scanner's display. Extended test results for up to 500 cable tests can be saved for printing.

NOTE

The accuracy of cable length measurement depends upon the NVP value entered for the selected cable type. Although the preset values will give reasonably accurate readings in most cases, the NVP of your cable may be measured to achieve maximum accuracy. Refer to Chapter 7, Cable Calibration.

3.1.1 CABLE TYPE SELECTION

The correct cable type must be selected before performing any tests.

The Scanner is programmed with several preset cable types, which are listed in Appendix B. Two additional cable types may be custom defined and stored in nonvolatile memory—instructions for entering cable data are in **Chapter 8, Custom Cable Types**.

3.1.2 TESTING TWISTED-PAIR CABLES

Follow these steps to test twisted-pair cables.

- Set the rotary function selector to AUTOTEST. The display shown in Fig. 3-2 will appear. The currently selected cable type will be shown in the bottom line of the display.

Loopback Adapter
NOT CONNECTED!

10BASE-T Cat 3

Fig. 3-1. Currently Selected Cable Type.

SCAN-LAN 180 CABLE SCANNER

- Press the ▼ or ▲ button until the desired cable type is displayed.
- Plug one end of the cable to be tested into the RJ-45 connector on the Scanner.
- Plug the other end of the cable into the Remote Unit.
- Make sure that no other cable is plugged into the BNC connector.
- To test a cable that is wired to jacks, use the RJ-45 patch cables between the jacks and the Scanner and/or Remote Unit.

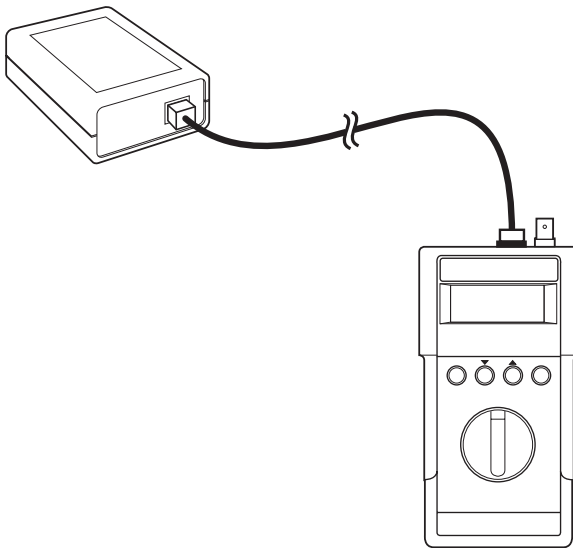

Fig. 3-2. Testing Twisted-Pair Cables.

During Autotest, the Scanner will execute the following cable tests:

- Background Noise
- Wire Map
- Length
- NEXT
- Attenuation
- Characteristic Impedance

Following are descriptions of each test.

Noise

The Noise test is performed first to determine if background noise is present on the cable. A display of the test results, shown in Fig. 3-3, will appear only if the test fails; however, the printed report will always include the measured noise level.

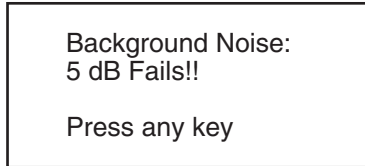

Fig. 3-3. Noise Test.

Wire Map

This test verifies correct wiring of all four pairs in a twisted-pair cable. Any shorts, opens, or incorrect wiring will be displayed. Following are example Wire Map displays.

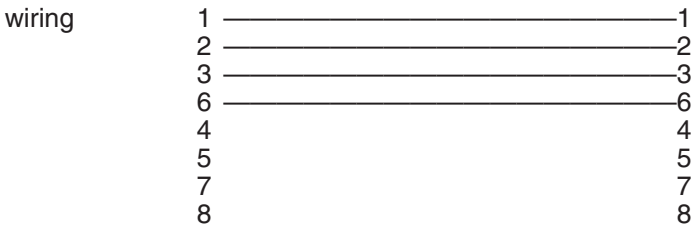
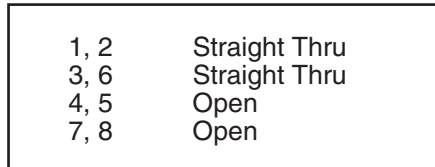
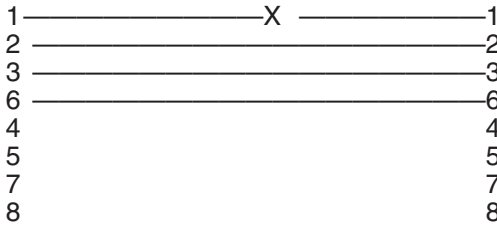

Fig. 3-4. Wire Map.

1, 2	Open
3, 6	Straight Thru
4, 5	Open
7, 8	Open

wiring



1, 2	Shorted
3, 6	Straight Thru
4, 5	Open
7, 8	Open

wiring

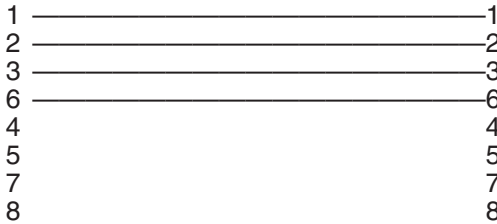

1, 2	Cross to 3,6
3, 6	Cross to 1,2
4, 5	Open
7, 8	Open

Fig. 3-4. Wire Map (continued).



1,2	Reversed
3,6	Reversed
4,5	Open
7,8	Open



1,2	?????
3,6	Straight Thru
4,5	Open
7,8	Open

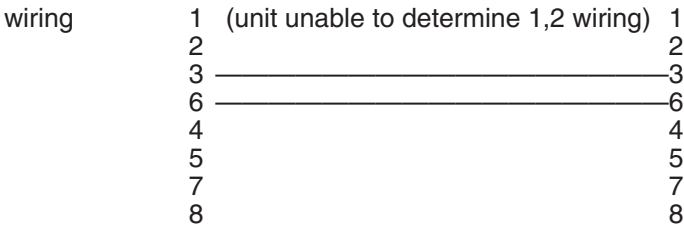

Fig. 3-4. Wire Map (continued).

The Scanner verifies that the transmit and receive pairs for the selected LAN environment are present. Following are the transmit and receive pairs.

Ethernet — 1,2 and 3,6

Token Ring — 3,6 and 4,5

If the wiring is incorrect for the selected LAN environment, the screen shown in Fig. 3-5 will be displayed.

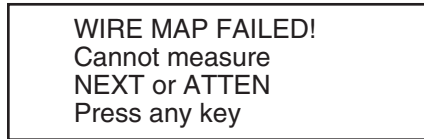

WIRE MAP FAILED!
Cannot measure
NEXT or ATTN
Press any key

Fig. 3-5. Incorrect Wiring Screen.

Because of faulty wiring, the Scanner cannot measure near-end crosstalk or attenuation. The Scanner will measure length and characteristic impedance. Press any key to continue with Autotest.

Length

Length of each pair, including distance to any anomalies, is measured using the NVP indicated on the display.

The display shown in Fig. 3-6 will appear while the length test is being performed.

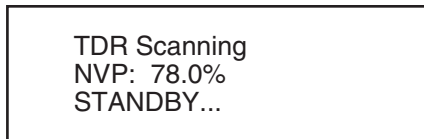

TDR Scanning
NVP: 78.0%
STANDBY...

Fig. 3-6. Length Test Display.

Length test results will be displayed briefly before proceeding.

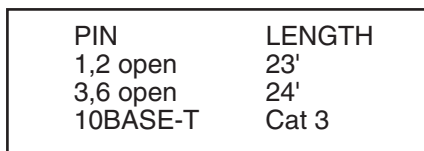

PIN	LENGTH
1,2 open	23'
3,6 open	24'
10BASE-T	Cat 3

Fig. 3-7. Length Test Results.

Any anomalies found will be flashed on the display. Anomalies are reflections from impedance discontinuities located between the Scanner and the end of the cable. They can be caused by a faulty punch down block connection (twisted-pair networks) or badly crimped cables (coax networks).

PIN	LENGTH
1,2 open	82'
3,6 anom1	43'
Press any key	

Fig. 3-8. Length Test Anomalies.

Near End Crosstalk (NEXT)

This test measures crosstalk between pairs from 5 to 20 MHz for Category 4 and 5 cables, and from 5 to 16 MHz for Category 3 cables. The largest measured crosstalk is shown in the final test display. The frequency of this measurement, along with the dB value, is included in the printed test report.

If excessive crosstalk (<20 dB) is detected between any pairs in the cable, a Split Pair Warning is displayed.

Split Pair!!
Pair: 3,6 splits
Pair: 4,5
Press any key

Fig. 3-9. Split Pair Warning Screen.

If excessive crosstalk compared to EIA/TIA specifications is measured between any pairs, an EIA Warning screen is displayed.

EIA 568 WARNING
12/78 NEXT: 20 dB
doesn't meet Cat5
Press any key

Fig. 3-10. EIA Warning Screen.

Attenuation

Signal loss over the length of the cable is measured between 5 and 20 MHz for Category 4 and 5 cables, between 5 and 16 MHz for Category 3 cables. The highest attenuation (greatest loss) over the frequency range will be displayed. Attenuation is measured in a loopback mode between the transmit and receive pairs, but is displayed as end-to-end loss. The frequency at which the greatest attenuation occurred is included in the printed test report.

If excessive attenuation compared to EIA/TIA 568 specifications is measured, an EIA Warning screen is displayed.

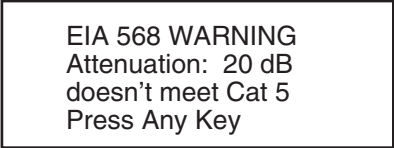
A rectangular box with a black border containing the following text:

EIA 568 WARNING
Attenuation: 20 dB
doesn't meet Cat 5
Press Any Key

Fig. 3-11. EIA Warning Screen.

Characteristic Impedance

Approximate characteristic impedance of the cable is measured. The following will be displayed if the test fails.

<p>Impedance: 130 Ω is Out of Range!! Press any key</p>
--

Fig. 3-12. Characteristic Impedance.

If measured impedance is within limits, the Scanner will not display the characteristic impedance. The measured impedance is included in the printed test report.

Test Results

After the Scanner has completed its cable tests, the unit displays a final screen with important measurements for twisted-pair cables.

Pass	24'
NEXT:	34 dB
Attenuation:	1 dB
OK for 10BASE-T	

Fig. 3-13. Test Results.

- A Pass/Fail indication will be displayed in the upper left corner. A Pass indicates that the cable meets or exceeds the IEEE specifications.
- Cable length is displayed in either feet or meters on the top line of the display. The units of length may be changed with the Special Setup function—see **Chapter 9, Special Setup**.
- NEXT measurement is displayed in dB units. A larger number is better, indicating lower crosstalk. A flashing NEXT reading indicates excessive NEXT.
- The maximum measured cable attenuation is displayed in dB. A smaller number is better, indicating lower attenuation. A flashing attenuation indicates excessive cable attenuation.
- The fourth line of the display indicates whether the cable will work in the selected LAN environment, 10BASE-T or Token Ring.

Printed Test Report

A typical printed report for Autotest twisted-pair cable is reproduced on the following page, with a description of the items on the report below.

1. SETUP—indicates the Scanner setup used during Autotest.
2. TEST RESULTS—Cable measurements performed by the Scanner including Length, Wire Map, Attenuation, and NEXT.
3. COMMENTS—Comments relating to each of the test results, including test limits and possible problems.
4. TEST SUMMARY—Pass or fail.
5. Date, Operator, Notes—Administrative information

SCAN-LAN 180 AUTOTEST REPORT #6

CIRCUIT IDENTIFIER: ----

SETUP:

Cable: 10BASE-T Cat3 (EIA/TIA 568 Category 3 Cable for 10BASE-T)

Connector: RJ-45 (10BASE-T) Tx=1,2 Rx=3,6

NVP: 62.0%

Fault Anomaly Threshold: 7%

TEST RESULTS:

Tx Length: 20 feet

Tx Cable Impedance:

COMMENTS:

Cable too short or no reflections

PASS: Cable too short to measure

Rx Length: 20 feet

Rx Cable Impedance:

Cable too short or no reflections

PASS: Cable too short to measure

Wire Map:

Pair 1,2 Straight through

Pair 3,6 Straight through

Pair 4,5 Straight through

Pair 7,8 Straight through

PASS: Required pair

PASS: Required pair

Not used

Not used

Attenuation: (± 2 dB) 0 dB @ 6.5 MHz

EIA check: (± 2 dB) 0 dB @ 16.0 MHz

PASS: 11.5 dB maximum expected, 5-10 MHz

PASS: 4 dB maximum expected, 5-16 MHz

NEXT: (Tx/Rx ± 2 dB) 47 dB @ 9.8 MHz

PASS: 30.6 dB @ 5 MHz, 26 dB @ 10 MHz min

EIA check, 5-16 MHz (± 2 dB accuracy)

Pairs 3,6 to 1,2 41 dB @ 15.4 MHz

Pairs 3,6 to 4,5 37 dB @ 15.8 MHz

Pairs 3,6 to 7,8 48 dB @ 15.4 MHz

Pairs 1,2 to 4,5 48 dB @ 16.0 MHz

Pairs 1,2 to 7,8 48 dB @ 15.4 MHz

Pairs 4,5 to 7,8 48 dB @ 16.0 MHz

PASS: 24 dB minimum expected

PASS: 23 dB minimum expected

PASS: 24 dB minimum expected

PASS: 23 dB minimum expected

PASS: 24 dB minimum expected

PASS: 23 dB minimum expected

Background noise: 64 dB

Signal/Noise Ratio: 47 dB

(SNR=NEXT-Attenuation)

PASS: Greater than 39 dB

PASS: 16 dB minimum expected, 5-10 MHz

TEST SUMMARY: Passes IEEE 802.3 10BASE-T Specifications

Date: Operator:

Notes:

Fig. 3-14. Autotest Report.

3.1.3 TESTING COAX CABLES

- Set the rotary function selector to AUTOTEST. The following display will appear. The currently selected cable type will be shown in the bottom line of the display.

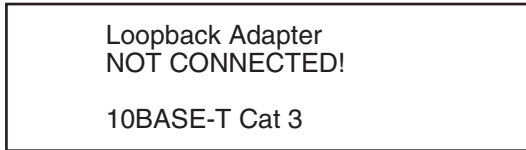

```
Loopback Adapter
NOT CONNECTED!

10BASE-T Cat 3
```

Fig. 3-15. Currently Selected Cable Type.

- Press the ▼ or ▲ button until the desired cable type is displayed.
- Attach one end of the cable to the BNC connector on the Scanner. Do not locate the Scanner in the middle of the cable.
- Attach a terminator of the correct value for the cable type to the other end of the cable.
- Make sure that no other cable is plugged into the RJ-45 connector.

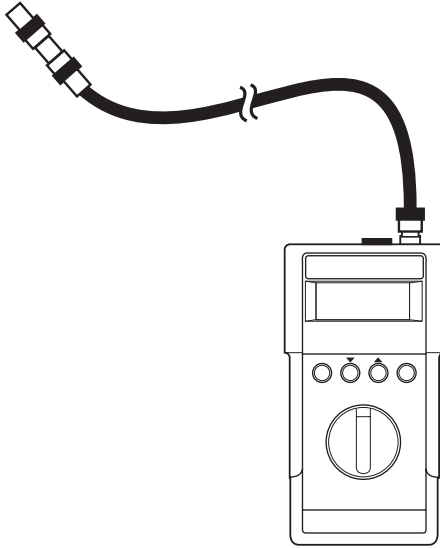

Fig. 3-16. Testing Coax Cables.

The Scanner performs the following tests during Autotest of coaxial cables:

- Background Noise
- Termination Resistance
- Characteristic Impedance
- Length and Anomalies

Following are descriptions of each test.

Background Noise

The Noise test is performed first to determine if background noise is present on the cable.

If the noise test fails, the display will appear as shown in Fig. 3-17.

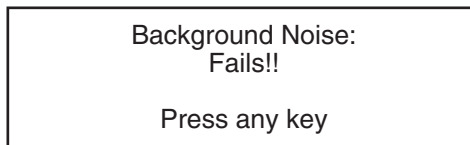

Fig. 3-17. Background Noise Screen.

Characteristic Impedance

The characteristic impedance of the cable is measured.

Termination Resistance

Termination resistance at the end of the cable is measured.

Length and Anomalies

The distance to opens, shorts, or anomalies are located. While the length test is being performed, the screen shown in Fig. 3-18 will be displayed.

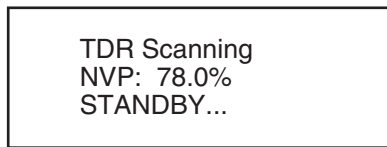

Fig. 3-18. Length Test Screen.

If an anomaly is located on the cable, the following will be displayed. Anomalies could be caused by cable stubs, damaged cables, or cable-type mismatches.

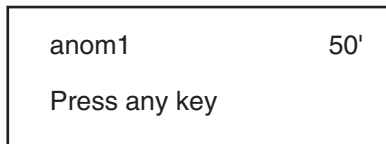

Fig. 3-19. Anomaly Screen.

Test Results

At the conclusion of the Autotest, the Scanner will display the following important measurements for coaxial cables.

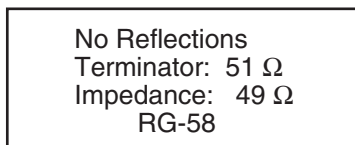

Fig. 3-20. Test Results.

- No Reflections will be displayed on the top line if the cable is terminated properly and no cable anomalies are present.
- Terminator value in ohms is displayed. A flashing “Terminator” indicates a bad terminator.

OPEN indicates a defective or missing terminator. SHORT indicates a shorted cable.

- Impedance value in ohms is displayed. A flashing impedance value indicates a characteristic impedance value that does not meet specifications for the selected cable type.

Determining Length Using Autotest

To measure the length of the coaxial cable segment using Autotest, remove the terminator from the end of the cable segment. The length of the cable segment will be indicated on the display.

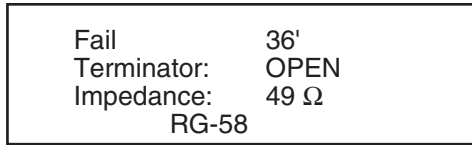

Fig. 3-21. Measuring the Length of the Coaxial Segment.

- Length of cable segment.

Printed Test Report

A typical Autotest coax printed report is reproduced in Fig. 3-22; the items on the report are described on the next page.

```

SCAN-LAN 180 AUTOTEST REPORT #1

CIRCUIT IDENTIFIER: ----

SETUP:
Cable: 10BASE2
Connector: BNC
NVP: 78.0%
Fault Anomaly Threshold: 7%

TEST RESULTS:
Length: 153 feet
Cable Impedance: 52 ohms
* Termination Resistance: open
Background Noise: 60 mV

COMMENTS:
PASS
PASS: 50 ohms nominal
FAIL: Underminated cable
PASS: 400 mV max

TEST SUMMARY: FAIL
<<<< * Fails + Caution >>>>

Date: Operator:

Notes:
    
```

Fig. 3-22. Autotest Report.

- **SETUP**—Indicates the Scanner setup used during Autotest.
- **TEST RESULTS**—Cable measurements performed by the Scanner including Length, Characteristic Impedance, Termination Resistance, and noise level.
- **COMMENTS**—Comments relating to each of the test results, including test limits and possible problems.
- **TEST SUMMARY**—Pass or Fail.
- **Date, Operator, Notes**—Administrative information.

Saving Test Results

Extended test results from up to 400 cable tests can be stored in the Scanner's nonvolatile memory and recalled later for printing.

- When the Autotest is complete, press the Save button.

The display will initially show a report number one higher than the last number used. If you want to save this test report with a different number, press the ▼ or ▲ button until the desired report number is displayed.

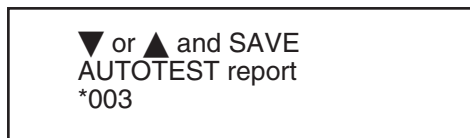

Fig. 3-23. SAVE AUTOTEST Report.

- Press the Save button to store the test results.

If Circuit Identifiers have been enabled (see **Chapter 9, Special Setup**), the Scanner will prompt for the four-character cable ID.

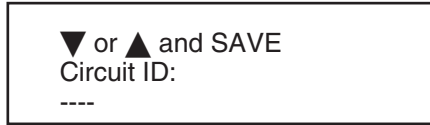

Fig. 3-24. Circuit ID.

- Press the ▼ or ▲ button until the desired character (A through Z, 0 through 9, hyphen (-) or blank) appears at the blinking cursor.
- Press the Save button to advance to the next character position, then select a character. Repeat until all four characters have been entered.

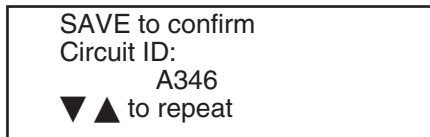

Fig. 3-25. Save Screen.

- The unit will prompt for confirmation. Press the Save button again to store the test results, or press the ▼ or ▲ button to re-enter the circuit ID.

Use the Print function to produce hard copies of test results.

3.1.4 CHECKING MULTIPLE CABLES

The Scanner senses when a change occurs in the cable connection and restarts the test. Use this feature to easily test many cables—just plug in the new cable, and the test results will appear in several seconds.

When no activity has been detected for five minutes, the Scanner will automatically power down.

3.2 Individual Cable Tests

Wiring, Cable Length, and Noise can each be tested separately by the Scanner. The individual tests run faster than the full Autotest function. These functions are especially useful when you need to check only wiring or cable length for a number of cables.

3.2.1 WIRE MAP (TWISTED-PAIR CABLES ONLY)

- Set the rotary function selector to Wire Map.
- Press the ▼ or ▲ button until the desired cable type is displayed.
- Connect the cable to the RJ-45 connector on the Scanner.
- Plug the other end of the cable into the Remote Unit.

Test results will be shown in the display, with the location of any wiring errors notes (refer to the Autotest section in this chapter). The Scanner will rerun the Wire Map test and update the display every two seconds.

1,2 Straight Thru
3,6 Straight Thru
4,5 Straight Thru
7,8 Straight Thru

Fig. 3-26. Wire Map Test.

3.2.2 LENGTH TEST

NOTE

The accuracy of cable length measurements depends upon the NVP value entered for the selected cable type. Although the preset values will give reasonably accurate readings in most cases, the NVP of your cable may be measured to obtain maximum accuracy. Refer to Chapter 7, Cable Calibration.

- Connect the cable to the appropriate connector on the Scanner.

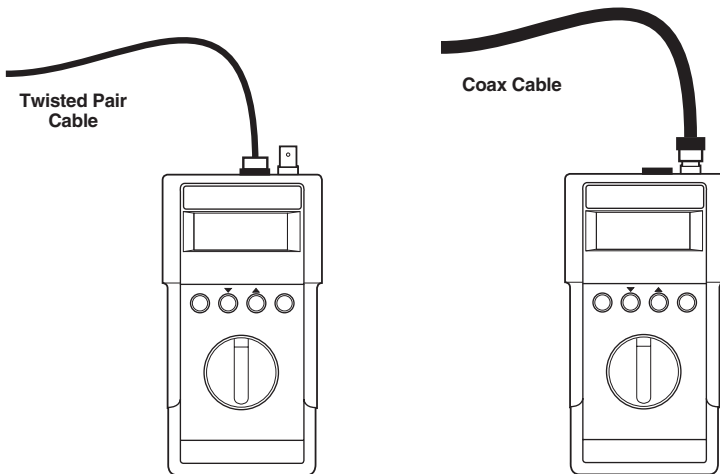

Fig. 3-27. Connecting the Cable to the Scanner.

SCAN-LAN 180 CABLE SCANNER

- Set the rotary function selector to LENGTH.
- Press the ▼ or ▲ button until the desired cable type is displayed.
- Make sure that any terminators are disconnected when testing coax cable. The Remote Unit is not required for testing length of twisted-pair cable.

At the completion of the Length measurement, the length of the cable will be displayed.

PIN	LENGTH
1,2 open	23'
3,6 open	22'
10BASE-T Cat3	

open at 62'
RG 58

Fig. 3-28. Length of the Cable.

Any anomalies found will be flashed on the display. Anomalies are reflections from impedance discontinuities located between the Scanner and the end of the cable. They can be caused by a faulty punchdown-block connection (twisted-pair networks) or badly crimped cables (coax networks).

PIN	LENGTH
1,2 open	23'
3,6 anom1	43'
10BASE-T Cat3	

anom1 at	62'
RG 58	

Fig. 3-29. Twisted Pair and Coax Cable Anomalies.

3.2.3 NOISE TEST

This test counts noise impulses (spikes) above a preset minimum threshold on an idle cable segment. The default noise threshold setting is 260 mV; refer to **Chapter 9, Special Setup**, if you want to change this value.

The Noise Test runs continuously until stopped by the user. Use of the wall plug-in supply is recommended if the test is to be run for an extended period.

- Connect the cable to the appropriate connector on the Scanner. The cable should not be connected to an active network; the test will record network traffic as noise impulses.

For most accurate measurements, the cable should be properly terminated. If testing twisted-pair cable, plug the far end of the cable into the Remote Unit. For coax cable, connect a terminator to the far end of the cable.

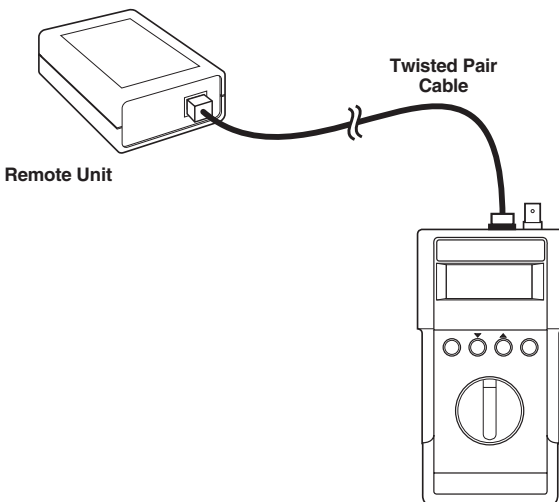

Fig. 3-30. Twisted-Pair Cable.

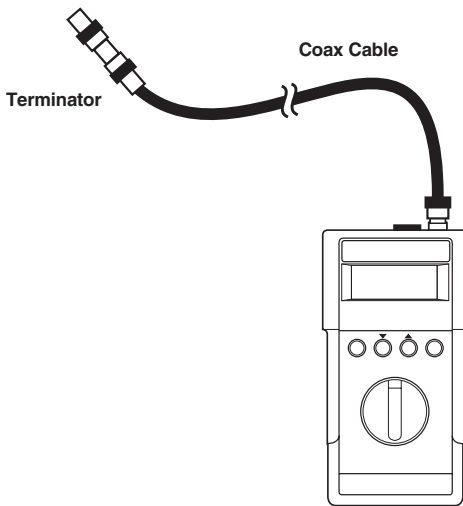

Fig. 3-31. Coax Cable.

- Set the rotary function selector to NOISE.
- Press the ▼ or ▲ button until the desired cable type is displayed.
- After 10 seconds, the display will give a PASS or FAIL result for the test.

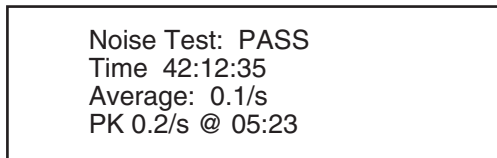

Fig. 3-32. Noise Test.

- Time shows the elapsed test time.
- Average shows the average noise impulses per second.
- PK (Peak) shows the worst case 1-second average noise and the time of occurrence since the start of the test in HH:MM format.

NOTE

For 10BASE-T cable, the maximum allowable impulse noise rate is 0.2/s with a 260 mV noise threshold.

4.0 Traffic Measurement

Live network traffic monitoring on 10BASE-T or coax Ethernet networks can be performed by the Scanner. Percentage of network use, peak traffic, and collisions are continuously shown in the display, along with a bar graph display of network activity. The unit also provides audio feedback of network activity.

The traffic test runs continuously. Use of the wall plug-in supply is recommended if the test is to be run for an extended period of time. Test results are saved in the Scanner's memory and can be printed when the test is completed. The printout includes a graph of network activity over time, showing average use, peak use, percentage of collisions, packet counts, and jabber conditions.

For 10BASE-T networks, the Scanner automatically generates link pulses to activate the hub and reports whenever a link state with the hub is lost.

4.1 Traffic Test

- Set the rotary function selector to TRAFFIC.
- Attach the network cable to the appropriate connector on the Scanner.
- If the presently selected cable type is not one of the following:
 - 10BASE-T Cat 3-5, 10BASE2, 10BASE5, RG-58, or RG-58 Foam,the Scanner will display:

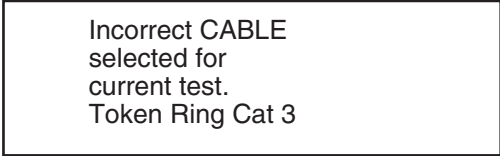

Incorrect CABLE
selected for
current test.
Token Ring Cat 3

Fig. 4-1. Traffic Test.

- If the correct cable type has not been previously selected, press the ▼ or ▲ button until the correct cable type is shown at the bottom of the display.

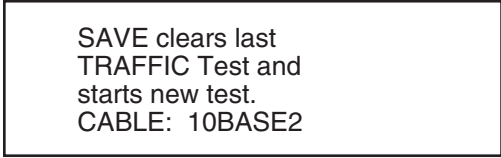

SAVE clears last
TRAFFIC Test and
starts new test.
CABLE: 10BASE2

Fig. 4-2. Traffic Test Screen.

- Press the SAVE button to clear the previous traffic test from memory and start a new test. Whenever there is traffic detected, an audible tone is generated; the pitch of the tone is proportional to the level of network use. The tone may be disabled using Special Setup.

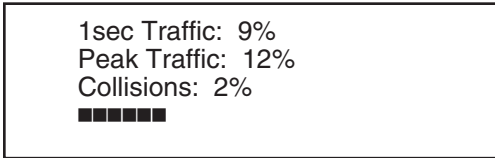

1sec Traffic: 9%
Peak Traffic: 12%
Collisions: 2%
■■■■■■

Fig. 4-3. Traffic Test.

The display will show a continuous reading of traffic conditions on the network.

- 1sec Traffic—shows the average network use over the last second and gives an indication of current traffic levels.
- Peak Traffic—the highest one-second average traffic over the duration of the test.
- Collisions—shows the current collision rate over the last second, expressed as a percentage of total packets transmitted. Collisions are counted when runt packets (shorted than a valid minimum packet length) are detected.
- bar graph—displays the instantaneous traffic level, scaled from 0 on the left side of the display to 60% on the right side.

For 10BASE-T networks, the bottom line will display “No link pulse” whenever link to the hub is lost, and will display “Wrong polarity” when reverse-polarity link pulses are detected.

If packets are detected that are longer than 20 msec, the display in Fig. 3-4 will be shown until the problem is cleared.

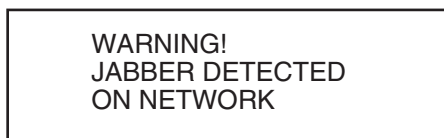

Fig. 4-4. Jabber Detected Display.

- Select another test or turn the unit off when you want to stop the traffic test. The traffic measurements will be automatically stored in memory and can be printed at a later time.

NOTE

Network throughput may be impaired when traffic levels exceed 25-28%. Collision rates exceeding 3% indicate possible network problems.

4.2 Printing Traffic Reports

The traffic report stored in the Scanner’s memory may be printed on a standard serial printer. Refer to **Chapter 5, Printing Test Reports**, for instructions on using a printer with the Scanner.

Printed traffic reports feature a graphic display of network activity. Each horizontal line represents traffic with average use, peak use, and collisions shown. Jabber conditions, loss of link connection (for 10BASE-T networks), and the number of packets per second are reported at the end of each line.

A typical traffic report is reproduced on the next page, followed by a description of the various items on the report.

SCAN-LAN 180 CABLE SCANNER

SCAN-LAN 180 NETWORK TRAFFIC REPORT

Start Time:

Date:

Operator:

Notes:

Cable: 10BASE-T

Time HH:MM:SS	Percent Network Utilization											Packet		
	0	5	10	15	20	25	30	35	40	45	50		75	100
00:00:00	+	+	+	+	+	+	+	+	+	+	+	C	Rate	1
00:00:01	-													0
00:00:02													0	
00:00:03													0	
00:00:04													0	
00:00:05	*_													42
00:00:06	*_													12
00:00:07													0	
00:00:08													0	
00:00:09													0	
00:00:10	-												0	0
00:00:11													0	
00:00:12													0	
00:00:13													0	
00:00:14	*_													1
00:00:15	**_C_												JABBER	51
00:00:16	**_													48
00:00:17													0	
00:00:18													0	
00:00:19	-													0
00:00:20													0	
00:00:21													0	
00:00:22													0	
00:00:23	*_												1	
00:00:24	***_													52
00:00:25	*C*****_													211
00:00:26	***C*****_													198
00:00:27	***C*****_													180
00:00:28	*****_C													219
00:00:30														143
00:00:31	*_												0	
00:00:32	*_												1	
00:00:33													0	
00:00:34													0	
00:00:35	-													0
00:00:36													0	
00:00:37	*_												22	
00:00:38	*_													10
00:00:39														0
00:00:40													0	
00:00:41	*_													1

Fig. 4-5. Network Traffic Report.

- **Time**—the elapsed time since the start of the test. The time scale is automatically compressed to ensure that the test report never exceed seven pages.
- **Average Utilization**—the average utilization of network bandwidth over the indicated time interval. An average utilization of greater than 30-40% indicates a heavily loaded network. A network bridge may be used to localize traffic and improve network response.
- **Peak Utilization**—the peak network utilization for any 20 msec interval within the indicated time interval.
- **% Collisions**—the percentage of transmitted packets resulting in a collision. A large percentage of collisions possibly indicates a faulty station, cable segment, or a cable segment that is too long.
- **Packet Rate**—the average packet rate over the indicated time interval.
- **NO LINK (10BASE-T networks only)**—indicates that there were no LINK pulses received from the 10BASE-T hub, possibly as a result of a faulty hub or cable segment leading to the hub.
- **JABBER**—indicates that an illegal packet of length greater than 20 msec was received during the time interval.

5.0 Printing Test Reports

One traffic report and 500 cable test reports can be printed from the Scanner's nonvolatile memory. The printed reports provide more extensive test results than are available from the display screen during Autotest.

The printer must have an RS-232 serial interface. Connect the printer to the Scanner with a standard IBM AT serial printer cable (equipped with a female DB9 connector at the Scanner end). The printer cable may be obtained from your Scanner dealer.

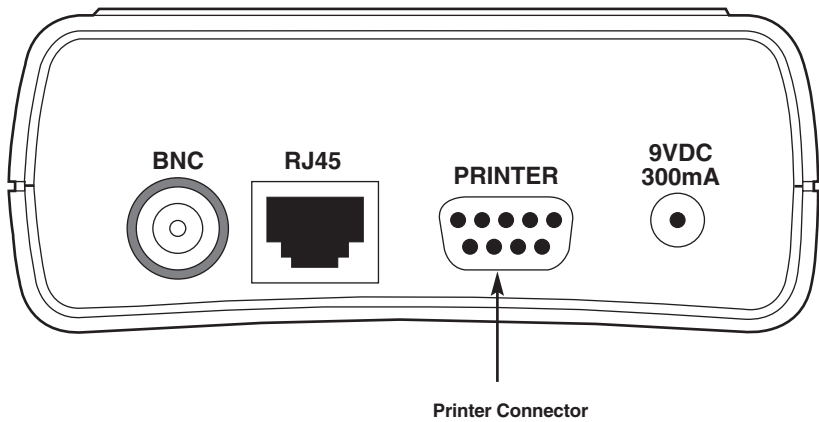

Fig. 5-1. Printer Connector.

- Set the rotary function selector to PRINT. The screen shown in Fig. 5-2 appears.



Fig. 5-2. Print Screen.

- Press the ▲ or ▼ button to select between All Reports, Traffic Report, or an individual Autotest.
- Press the SAVE button.
- Press the ▼ or ▲ button to select the bit rate that matches the printer setting (typically 9600 bps).

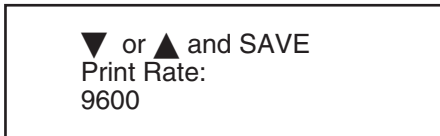

Fig. 5-3. Print Rate Screen.

- Press the SAVE button. Print data will be sent to the serial printer. To abort a printout, press any key.

NOTE

Make sure that the printer is set to the selected bit rate: 8 data bits, no parity, one or two stop bits, and DTR (hardware) flow control.

After printing is completed, the screen shown in Fig. 5-4 will be displayed.

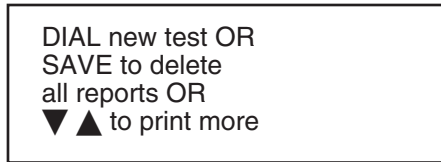

DIAL new test OR
SAVE to delete
all reports OR
▼ ▲ to print more

Fig. 5-4. Printing Complete.

- Press the SAVE button to delete all test reports from memory, press the ▼ or ▲ button to print another report, or dial a new test with the rotary function selector to exit printing mode without deleting test results.

If you press the SAVE button, the Scanner will prompt for confirmation before deleting the test results.

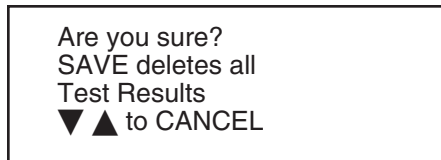

Are you sure?
SAVE deletes all
Test Results
▼ ▲ to CANCEL

Fig. 5-5. SAVE.

```
SCAN-LAN 180 AUTOTEST REPORT #1

CIRCUIT IDENTIFIER: —

SETUP:
  Cable: 10BASE2
  Connector: BNC
  NVP: 78.0%
  Fault Anomaly Threshold: 7%

TEST RESULTS:                COMMENTS:
  Length: 153 feet           PASS
  Cable Impedance: 52 ohms   PASS: 50 ohms nominal
  *Termination Resistance: open  FAIL: Unterminated cable
  Background Noise: 60 mV     PASS: 400 mV max

TEST SUMMARY: FAIL

<<<< * Fails                + Caution >>>>

Date:                          Operator:

Notes:
```

Fig. 5-6. Typical Printed Report #1.

SCAN-LAN 180 CABLE SCANNER

SCAN-LAN 180 AUTOTEST REPORT #6 CIRCUIT IDENTIFIER: —

SETUP:

Cable: 10BASE-T Cat3 (EIA/TIA 568 Category 3 Cable for 10BASE-T)

Connector: RJ-45 (10BASE-T) TX=1,2 RX=3,6

NVP: 62.0%

Fault Anomaly Threshold: 7%

TEST RESULTS:

COMMENTS:

TX Length: 20 feet

Cable too short or no reflections

TX Cable Impedance:

PASS: Cable too short to measure

Wire Map:

Pair 1,2 Straight through

PASS: Required pair

Pair 3,6 Straight through

PASS: Required pair

Pair 4,5 Straight through

Not used

Pair 7,8 Straight through

Not used

Attenuation: (± 2 dB) 0 dB @ 6.5 MHz PASS: 11.5 dB maximum expected, 5-10 MHz

EIA check: (± 2 dB) 0 dB @ 16.0 MHz PASS: 4 dB maximum expected, 5-16 MHz

NEXT: (TX/RX ± 2 dB) 47 dB @ 15.4 MHz PASS: 24 dB minimum expected

EIA check, 5-16 mHz (± 2 dB accuracy)

Pairs 3,6 to 1,2 41 dB @ 15.4 MHz PASS: 24 dB minimum expected

Pairs 3,6 to 4,5 37 dB @ 15.8 MHz PASS: 23 dB minimum expected

Pairs 3,6 to 7,8 48 dB @ 15.4 MHz PASS: 24 dB minimum expected

Pairs 1,2 to 4,5 48 dB @ 16.0 MHz PASS: 23 dB minimum expected

Pairs 1,2 to 7,8 48 dB @ 15.4 MHz PASS: 24 dB minimum expected

Pairs 4,5 to 7,8 48 dB @ 16.0 MHz PASS: 23 dB minimum expected

Background Noise: 64 dB

PASS: Greater than 39 dB

Signal/Noise Ratio: 47 dB

PASS: 16 dB minimum expected, 5-10 MHz

(SNR=NEXT-Attenuation)

TEST SUMMARY: Passes IEEE 802.3 10BASE-T Specifications

Date:

Operator:

Notes:

Fig. 5-7. Printed Report Example #2.

SCAN-LAN 180 NETWORK TRAFFIC REPORT															
Start Time:	Date:	Operator:													
Notes:															
Cable: 10BASE-T															
***Average Utilization			—Peak Utilization					c= % Collisions							
Percent Network Utilization															
Time	0	5	10	15	20	25	30	35	40	45	50	75	100	Packet	Rate
HH:MM:SS															
00:00:00	*											C	1		
00:00:01	-											0	0		
00:00:02											0	0			
00:00:03											0	0			
00:00:04											0	0			
00:00:05	*_-											0	42		
00:00:06	*_-											0	12		
00:00:07											0	0			
00:00:08											0	0			
00:00:09	NO LINK										0	0			
00:00:10	-											0	0		
00:00:11											0	0			
00:00:12											0	0			
00:00:13											0	0			
00:00:14	*_-											0	1		
00:00:15	**_-C_____											JABBER	51		
00:00:16	**_____											0	48		
00:00:17											0	0			
00:00:18											0	0			
00:00:19	-											0	0		
00:00:20											0	0			
00:00:21											0	0			
00:00:22											0	0			
00:00:23	*_-											0	1		
00:00:24	***_____											0	52		
00:00:25	*C*****_____											0	211		
00:00:27	***C***_____											0	198		
00:00:28	*****_____	C										0	180		
00:00:29	***_____											0	219		
00:00:30											143	0			
00:00:31	*_-											0	0		
00:00:32	*_-											0	1		
00:00:33											1	0			
00:00:34											0	0			
00:00:35	-											0	0		
00:00:37	*_-											0	0		
00:00:38	*_-											0	22		
00:00:39											10	0			
00:00:40											0	0			
00:00:41	*_-											0	1		

Fig. 5-8. Example Traffic Report #3.

6.0 Oscilloscope Scan

The Oscilloscope Scan function allows you to view a time-domain reflectometry scan on an oscilloscope. This advanced troubleshooting technique is intended for experienced TDR users.

6.1 UTP Cables

The accuracy of a cable scan depends upon correct TDR pulse-width settings. The following pulse widths are recommended for UTP cables:

Cables < 50 ft (15.2 m): 20 nsec

Cables between 50 ft. and 1250 ft (381 m):

80 nsec

Cables > 1250 ft.: 1.2 μ sec

- Refer to the Fig. 6-1. Using the supplied BNC patch cable, connect the Scanner to the oscilloscope input. The oscilloscope input impedance must be 1 megaohm or greater.
- Plug the UTP cable under test into the RJ-45 jack on the Scanner.

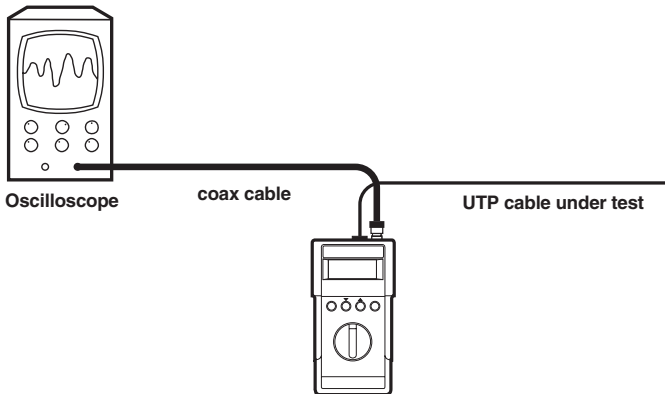

Fig. 6-1. Testing UTP Cables.

- Set up the oscilloscope as follows:

Trigger: rising edge, level=1 V

Timebase setting:

20 nsec TDR pulse-100 nsec/div

80 nsec TDR pulse-200 nsec/div

1.2 μ sec TDR pulse-5 μ sec/div

Vertical sensitivity: 1 V/div

- Set the rotary function selector to EXTENDED FUNCTIONS.
- Press the ▼ or ▲ button until “O’scope Scan” appears in the display, then press the SAVE button.

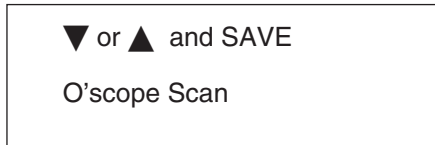

Fig. 6-2. O’scope Scan Screen.

- Press the ▼ or ▲ button to select the desired TDR pulse width, then press the SAVE button.

▲ or ▼ and SAVE
TDR pulse width:
20 nsec

Fig. 6-3. SAVE.

- Press the ▼ or ▲ button to select the pair to be scanned.

▼ or ▲ and SAVE
Scan pair:
1,2

Fig. 6-4. Scan Pair.

- Press the SAVE button to begin the test.
- The incident and reflected pulses will be displayed on the oscilloscope screen. Sample waveforms are shown in Figures 6-5 and 6-6.

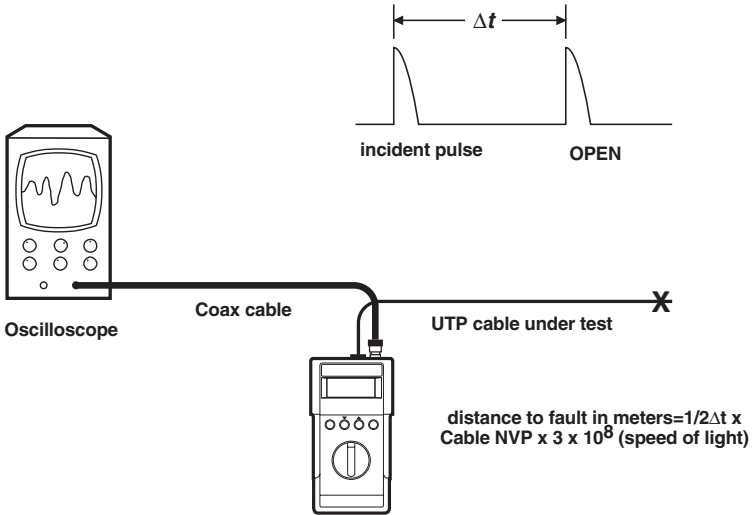

Fig. 6-5. Open.

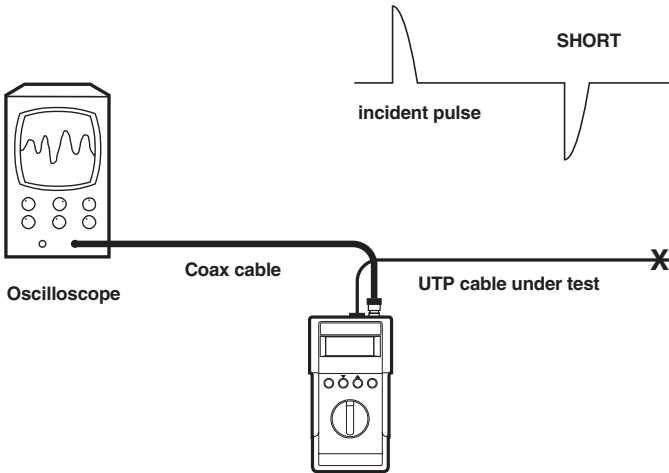

Fig. 6-6. Short.

6.2 Coax Cables

The accuracy of a cable scan depends upon correct TDR pulse-width settings. The following pulse widths are recommended for coax cables:

Cables < 50 ft (15.2 m): 20 nsec

Cables between 50 ft. and 1250 ft (381 m):

80 nsec

Cables > 1250 ft.: 1.2 μ sec

- Using the supplied BNC “T” adapter and BNC patch cable, connect the Scanner to the oscilloscope input. The oscilloscope input impedance must be 1 megohm or greater.
- Connect the coax cable under test to the BNC “T” adapter.

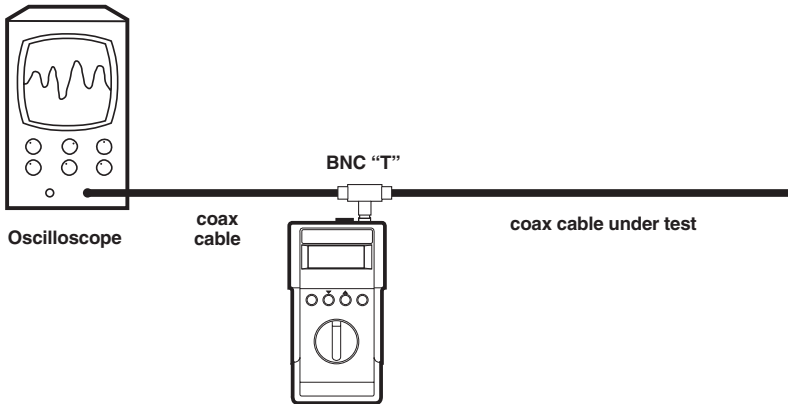

Fig. 6-7. Coax Cable.

- Set up the oscilloscope as follows:

Trigger: falling edge, level=-1 V

Timebase setting:

20 nsec TDR pulse-100 nsec/div

80 nsec TDR pulse-200 nsec/div

1.2 μ sec TDR pulse-5 μ sec/div

Vertical sensitivity: 1 V/div

- Set the rotary function selector to EXTENDED FUNCTIONS.
- Press the ▼ or ▲ button until O'scope Scan appears in the display, then press the SAVE button.

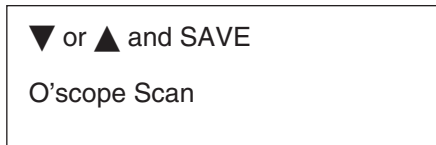

Fig. 6-8. O'scope Scan.

- Press the ▼ or ▲ button to select BNC cable type.

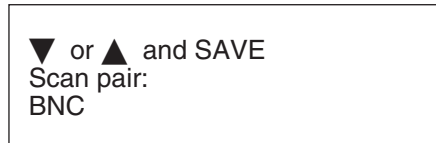

Fig. 6-9. BNC.

- Press the ▼ or ▲ button to select the desired TDR pulse width, then press the SAVE button.

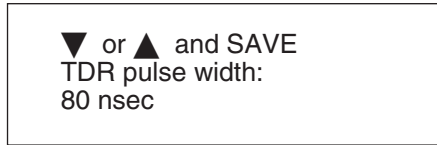

Fig. 6-10. TDR Pulse Width.

- Press the SAVE button to begin the test.
- The incident and reflected pulses will be displayed on the oscilloscope screen. Sample waveforms are shown in Figures 6-11 and 6-12.

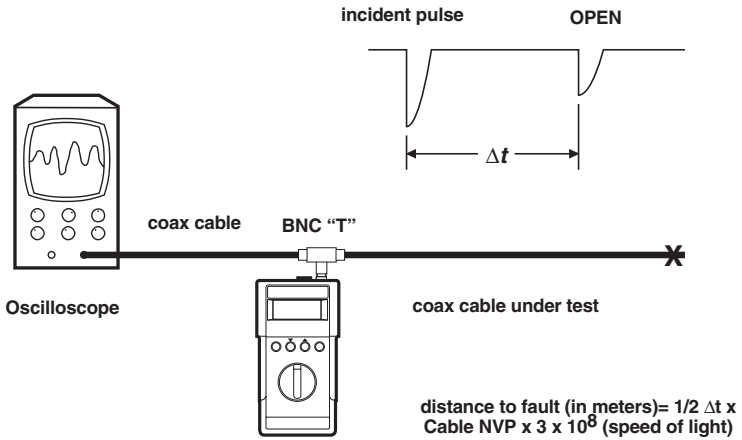

Fig. 6-11. Open.

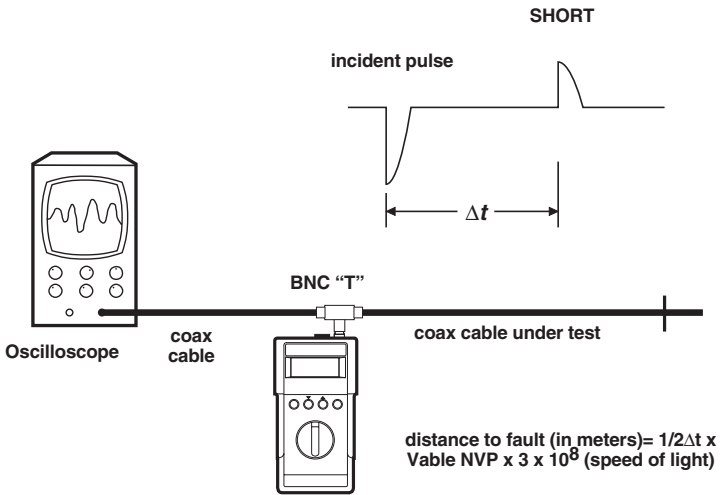

Fig. 6-12. Short.

7.0 Cable Calibration

Any custom or standard cable type may be calibrated for a specific cable spool. The calibrate cable function allows you to measure the NVP of a known length of cable and save it for additional measurements.

NOTE

The accuracy of cable length measurements depends upon the NVP value entered for the selected cable type. Although the preset values will give reasonably accurate readings in most cases, the NVP of your cable may be measured to achieve maximum accuracy.

- Connect an unterminated sample cable of known length to the appropriate connector on the Scanner. The cable must be at least 50 feet long (15.2 m) to get an accurate measurement. Longer lengths improve accuracy.

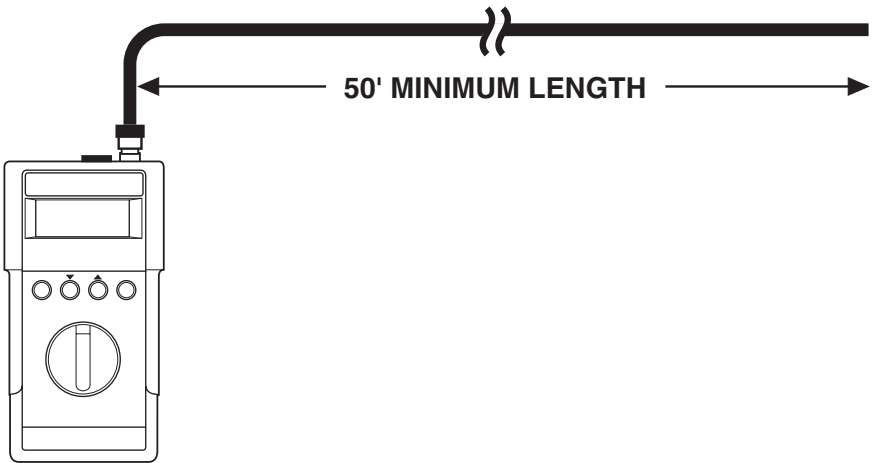
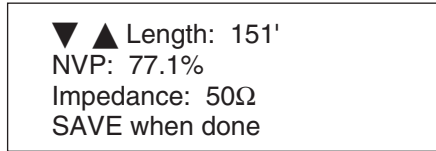

Fig. 7-1. Connecting a Cable to the Scanner.

- Set the rotary function selector to CALIBRATE CABLE.
- When the display shown in Fig. 7-2 appears, set the actual length of the cable with the ▼ or ▲ button, then press the SAVE button.



▼ ▲ Length: 151'
NVP: 77.1%
Impedance: 50Ω
SAVE when done

Fig. 7-2. Calibrate Cable.

- Press the ▼ or ▲ button to select the correct cable type, then press the SAVE button. The NVP and characteristic impedance settings are stored in nonvolatile memory and will be used for all subsequent tests of the selected cable type.

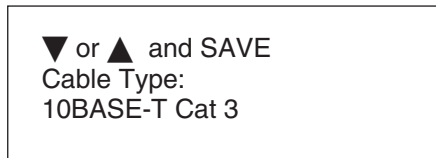

▼ or ▲ and SAVE
Cable Type:
10BASE-T Cat 3

Fig. 7-3. Cable Type.

8.0 Custom Cable Types

The Nominal Velocity of Propagation (NVP), characteristic impedance, and connector type for two custom cables may be defined and stored in nonvolatile memory.

- Set the rotary function selector to CUSTOM CABLE.
- Press the ▼ or ▲ button until the display shows the desired cable type, Custom #1 or Custom #2.

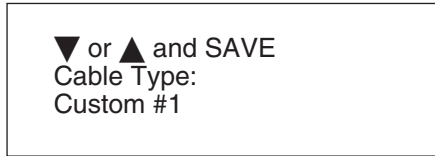

Fig. 8-1. Custom Cable.

- Press the SAVE button. The currently selected connector type will be shown in the display. Pin numbers for the transmit and receive pairs will be shown in the display if you select an RJ-45 connector type.

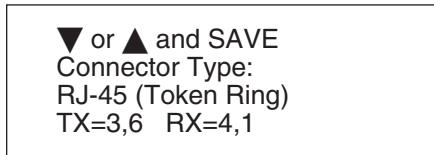

Fig. 8-2. Connector Type.

- Press the ▼ or ▲ button until the display shows the desired connector type: RJ-45 (10BASE-T), RJ-45 (Token Ring), or BNC.
- Press the SAVE button. The current characteristic impedance setting will be shown in the display.



Fig. 8-3. Characteristic Impedance.

- Press the ▼ or ▲ button to enter the correct characteristic impedance value.
- Press the SAVE button. The current NVP setting will be shown in the display.

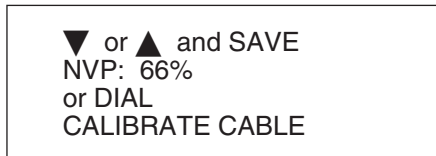

Fig. 8-4. Calibrate Cable.

- If you know the correct NVP value for your cable type, press the ▼ or ▲ button to change the NVP value. Press the SAVE button to store the NVP setting.
- If you do not know the correct NVP value, the Scanner can measure the cable's NVP using the CALIBRATE CABLE function—refer to **Chapter 7, Cable Calibration**.

- Set the rotary selector to a new test function to store the custom cable settings, press **SAVE** to abort any changes, or press the ▼ or ▲ button to revise the settings.

DIAL new test OR
SAVE to reset
parameters OR
▼▲ to repeat

Fig. 8-5. DIAL new test or SAVE to reset.

9.0 Special Setup

The units of length measurement, minimum fault threshold, and minimum noise threshold can be changed by the user. In addition, the audible warning tone and Circuit Identifiers for Autotest reports can be enabled or disabled from the Special Setup mode. Changes are retained after the unit is powered down.

9.1 Units of Length

- Set the rotary function selector to SPECIAL SETUP. The currently selected units, feet or meters, will be shown in the display.

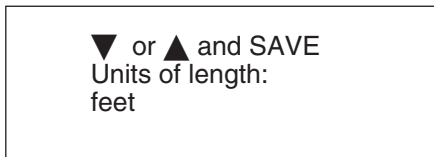

Fig. 9-1. Units of Length.

- Press the ▼ or ▲ button until the display shows the desired length units.
- Press the SAVE button to store the length-units setting.

9.2 Audible Tone

An audible tone can be enabled to alert the operator to test failures, network traffic during traffic tests, and noise during noise tests.

The current state of the audible tone, Enabled or Disabled, will be shown in the display.

- Press the ▼ or ▲ button to enable or disable the audible tone.
- Press the SAVE button to store the audible-tone setting.



▼ or ▲ and SAVE
Audible Tone:
Enabled

Fig. 9-2. Audible Tone.

9.3 Circuit Identifiers

This setting determines whether the Scanner will prompt for a four-character Circuit Identifier when saving an Autotest report.

The current state of the Circuit ID prompting, Enabled or Disabled, will be shown in the display.

- Press the ▼ or ▲ button to enable or disable the Circuit IDs.



▼ or ▲ and SAVE
AUTOTEST
Circuit IDs:
Disabled

Fig. 9-3. Circuit Identifiers.

- Press the SAVE button to store the Autotest circuit-ID setting.

9.4 Fault Threshold

The fault threshold is the minimum reflection level detected as an anomaly in the AUTOTEST or LENGTH test. Any reflections less than this threshold will be ignored by the Scanner. It is expressed as a percentage of the incident test pulse.

The currently selected fault threshold will be shown in the display. The default value is 7%, which corresponds to the worst-case allowable impedance discontinuity specified in IEEE 802.3 for coax cable. Anomalies that are greater than this threshold may impair network transmission.

- Press the ▼ or ▲ button until the display shows the desired fault threshold.
- Press the SAVE button to store the fault-threshold setting.



Fig. 9-4. Fault Threshold.

9.5 Noise Threshold

The noise threshold is the minimum detection level for noise impulses measured in the NOISE test.

The currently selected noise threshold will be shown in the display. The default value is 260 mV, which corresponds to the impulse noise specification for 10BASE-T.

- Press the ▼ or ▲ button until the display shows the desired noise threshold.
- Press the SAVE button to store the noise-threshold setting.



Fig. 9-5. Noise Threshold.

9.6 Saving/Resetting Changes

After all of the user-selectable settings have been entered, the Scanner will display the screen shown in Fig. 9-6.

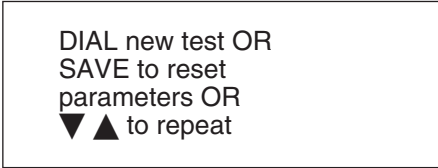

DIAL new test OR
SAVE to reset
parameters OR
▼ ▲ to repeat

Fig. 9-6. Saving/Resetting Changes.

- Set the rotary selector to a new test function to save the entered settings.
- Press the SAVE button to abort any changes and begin again.
- Press the ▼ or ▲ button to re-run Special Setup without deleting the changes just entered.

9.7 Resetting the Scanner to Factory Settings

The Scanner may be reset to factory settings using the RESET TO DEFAULT function. All settings, including the units of length, minimum fault threshold, minimum noise threshold, NVP, and characteristic impedance values for all cable types are reset to factory settings. In addition, all custom cable types are destroyed.

- Set the rotary selector to EXTENDED FUNCTIONS.

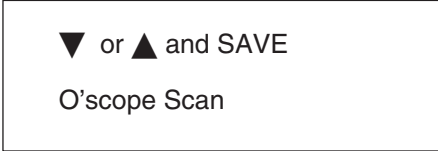

▼ or ▲ and SAVE
O'scope Scan

Fig. 9-7. Extended Functions.

- Press the ▼ or ▲ button to select the RESET TO DEFAULT function. Press the SAVE button.

Press SAVE to
reset all Scanner
parameters to
factory settings

Fig. 9-8. Reset to Default.

- Press the SAVE button to reset the Scanner to factory settings, or select another function using the rotary selector to abort.

10.0 Maintenance

10.1 Self-Test

The Scanner includes a self test function. Run this test periodically to assure that the unit is functioning properly.

- Set the rotary function selector to EXTENDED FUNCTIONS.
- Press the ▼ or ▲ button until Selftest is displayed.

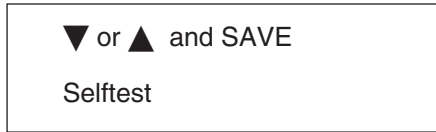

Fig. 10-1. Self-test.

- Press the SAVE button to start the self-test. Disconnect all cables from the Scanner, then press any button. The display shown in Fig. 10-2 will appear if all tests pass.

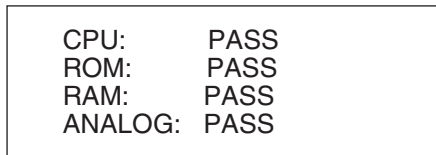

Fig. 10-2. All Tests Pass.

- If any test fails, the unit will beep twice, then display the fault.

CPU:	PASS
ROM:	PASS
RAM:	PASS
ANALOG:	FAIL

Analog failures:	
WIRE:	PASS
PLL:	PASS
OVL:	PASS

Analog failures:	
LINKPULSE:	PASS
MAXPULSE:	FAIL

Fig. 10-3. Fault Display.

- If the unit fails the self-test, replace the unit's batteries and rerun the test. If the unit continues to fail the self-test, note which tests fail and call Technical Support.

10.2 Power

10.2.1 SCAN-LAN 180 CABLE SCANNER

Power to the Scanner is supplied by two 9-volt alkaline batteries. The battery compartment is accessed by sliding off the cover on the bottom of the unit. The Scanner will typically operate for at least 8 hours on a pair of batteries. The unit continuously monitors battery voltage and will give the user a warning when the battery voltage is low.

The supplied wall plug-in power supply can power the Scanner to preserve battery life. Use the external supply when running extended duration tests, such as traffic monitoring or noise.

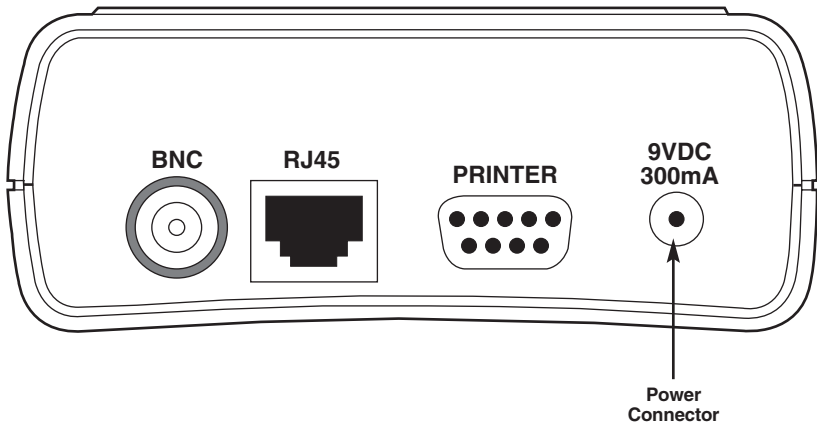

Fig. 10-4. Power Connector.

10.2.2 REMOTE UNIT

The Remote Unit, used for twisted-pair cable tests, requires one 9-volt alkaline battery. Slide off the cover to change the battery.

Power to the Remote Unit is applied only for brief intervals during cable tests, for minimal battery drain. The Scanner periodically tests remote operation and will warn you when the remote battery needs to be replaced.

If the units will remain unused for an extended period, remove the batteries to prevent damage from leakage.

Appendix A: Standard Cable Types

The cable types listed in Table A-1 are included in the standard cable library resident in the Scanner. Default NVP values may be altered with the CALIBRATE CABLE function.

Table A-1. Cable Types in the Scanner’s Library.

Designation	NVP	Impedance	Connector/ Pairs	Description
10BASE-T Cat 3	62%	100 ohms	RJ-45 1,2; 3,6	Category 3 unshielded twisted pair for 10BASE-T
10BASE-T Cat 4	66%	100 ohms	RJ-45 1,2; 3,6	Category 4 unshielded twisted pair for 10BASE-T
10BASE-T Cat 5	72%	100 ohms	RJ-45 1,2; 3,6	Category 5 unshielded twisted pair for 10BASE-T
Token Ring Cat 3	60%	100 ohms	RJ-45 3,6; 4,5	Category 3 unshielded twisted pair for Token Ring
Token Ring Cat 4	69%	100 ohms	RJ-45 3,6; 4,5	Category 4 unshielded twisted pair for Token Ring
Token Ring Cat 5	72%	100 ohms	RJ-45 3,6; 4,5	Category 5 unshielded twisted pair for Token Ring

Table A-1. Cable Types in the Scanner's Library (continued).

Designation	NVP	Impedance	Connector/ Pairs	Description
Token Ring STP	78%	150 ohms	RJ-45 3,6; 4,5	Category 5 unshielded twisted pair for Token Ring
10BASE2	80%	50 ohms	BNC	Thin Ethernet coax
10BASE5	78%	50 ohms	BNC	Non-plenum solid polyethylene core (Thicknet)
RG-58	66%	50 ohms	BNC	Non-plenum solid polyethylene core RG-58 coax
RG-58 Foam	78%	50 ohms	BNC	Foamed (cellular) polyethylene core RG-58 coax
RG-59	66%	75 ohms	BNC	Non-plenum solid polyethylene core RG-59 coax
RG-59 Foam	78%	75 ohms	BNC	Foamed (cellular) polyethylene core RG-59 coax
RG-62	84%	93 ohms	BNC	Semi-solid polyethylene core RG-62 (ARCNET®) coax

Appendix B: Cable Test Pass/Fail Limits

B.1 Twisted-Pair Cables

B.1.1 IEEE TEST LIMITS

The Scanner tests cables against IEEE specifications for the selected LAN environment (10BASE-T or Token Ring). The Autotest Results screen presented at the conclusion of Autotest indicates whether the cable meets IEEE specifications. See **Chapter 3, Cable Tests**, for further information.

Following are the IEEE test limits used by the Scanner while testing twisted-pair cabling.

Table B-1. 10BASE-T Pass/Fail Limits.

	10BASE-T Test Limits
Length	length < 100 meters
Background Noise	Background Noise > NEXT + 6 dB
SNR	SNR > 15 dB
Characteristic Impedance	Impedance = 100 ± 25 ohms
NEXT	Between 5 and 10 MHz, NEXT > 31 dB @ 5 MHz 27 dB @ 8 MHz 26 dB @ 10 MHz (NEXT > 26 - 15log(freq/10) where: freq = signal frequency in MHz)
Attenuation	Atten < 11.5 dB
Split Pair	NEXT < 20 dB

Table B-2. 4 Mbps Token Ring UTP Pass/Fail Limits.

	4 Mbps Token Ring Test Limits
Length	length < 100 meters
Background Noise	Background Noise > NEXT + 6 dB
SNR	SNR > 16 dB
Characteristic Impedance	Impedance = 100 ± 25 ohms
NEXT	Between 5 and 10 MHz NEXT > 31 dB @ 5 MHz 28 dB @ 8 MHz 26 dB @ 10 MHz
Attenuation	Between 5 and 10 MHz Atten < 7 dB @ 5 MHz 9 dB @ 8 MHz 10 dB @ 10 MHz
Split Pair	NEXT < 20 dB

Table B-3. 16 Mbps Token Ring Pass/Fail Limits.

	16 Mbps Token Ring Test Limits
Length	length < 100 meters
Background Noise	Background Noise>NEXT + 6 dB
SNR	SNR>21 dB
Characteristic Impedance	Impedance=100±25 ohms
NEXT	Between 5 and 20 MHz (16 MHz for Cat 3 cables) NEXT> 41 dB @ 5 MHz 38 dB @ 8 MHz 36 dB @ 10 MHz 33 dB @ 16 MHz 32 dB @ 20 MHz
Attenuation	Between 5 and 20 MHz (16 MHz for Cat 3 cables) Atten< 5 dB @ 5 MHz 6 dB @ 8 MHz 7 dB @ 10 MHz 9 dB @ 16 MHz 11 dB @ 20 MHz
Split Pair	NEXT<20 dB

Table B-4. 4/16 Mbps Token Ring STP Pass/Fail Limits.

	4/16 Mbps Token Ring Test Limits
Length	length < 100 meters
Background Noise	Background Noise>NEXT+6 dB
SNR	SNR>21 dB
Characteristic Impedance	Impedance=150 ±25 ohms
NEXT	TknRing4 Limit Between 5 and 10 MHz, NEXT>35 dB TknRing16 Limit Between 5 and 20 MHz, NEXT>35 dB
Attenuation	TknRing4 Limit Atten<10 dB TknRing16Limit Atten<10 dB
Split Pair	NEXT<20 dB

B.1.2 EIA/TIA 568 TEST LIMITS

In addition to testing cables against IEEE LAN specifications, the Scanner tests the measured cable attenuation and near-end crosstalk (NEXT) against applicable EIA/TIA Category specifications. If the cable fails to meet the EIA/TIA specifications for NEXT or attenuation, the Scanner will display an intermediate EIA/TIA Category Warning Screen. The measurements against the EIA/TIA Category Specifications can also be found in the Autotest printed report. See **Chapter 3, Cable Tests**, for further information.

EIA/TIA 568 and its supplement TSB36 specify the performance criteria for the cable itself and do not include the effects of connectors in the installed cable segment. Any installed cable will include some connecting hardware and will degrade from the cable specifications for attenuation and NEXT.

The Scanner takes into account that there will be several connectors in the installed cable segment by compensating for the resulting degradation from the cable specifications before comparing the measured segment attenuation and NEXT against 568 specifications. An additional 0.5 dB of attenuation and an additional 5 dB of NEXT have been included with the EIA 568 specifications to account for the connectors present in the cable segment.

Table B-5. EIA/TIA 568 Category Limits.

	Category 3 Limits
Attenuation	<p>Between 5 and 16 MHz Atten<the greater of 4 dB, or category limits (see below)+0.5 dB (connector losses)</p> <p>Category 3 limits 17 dB per 1000 ft @ 5 MHz 26 dB per 1000 ft @ 8 MHz 30 dB per 1000 ft @ 10 MHz 40 dB per 1000 ft @ 16 MHz</p>
NEXT	<p>Between 5 and 16 MHz, NEXT>category limits (see below)</p> <p>Category 3 limits 31 dB @ 5 MHz 28 dB @ 8 MHz 26 dB @ 10 MHz 23 dB @ 16 MHz</p>

Table B-5. EIA/TIA 568 Category Limits (continued).

	Category 4 Limits
Attenuation	<p>Between 5 and 20 MHz Atten<the greater of 4 dB, or category limits (see below)+0.5 dB (connector losses)</p> <p>Category 4 limits 13 dB per 1000 ft @ 5 MHz 19 dB per 1000 ft @ 8 MHz 22 dB per 1000 ft @ 10 MHz 27 dB per 1000 ft @ 16 MHz 31 dB per 1000 ft @ 20 MHz</p>
NEXT	<p>Between 5 and 16 MHz NEXT>category limits (see below)+5 dB (2 connector NEXT)</p> <p>Category 4 limits 46 dB @ 5 MHz 42 dB @ 8 MHz 41 dB @ 10 MHz 38 dB @ 16 MHz 36 dB @ 20 MHz</p>

Table B-5. EIA/TIA 568 Category Limits (continued).

	Category 5 Limits
Attenuation	<p>Between 5 and 20 MHz Atten<the greater of 4 dB, or category limits (see below)+0.5 dB(connector losses)</p> <p>Category 5 limits 13 dB per 1000 ft @ 5 MHz 18 dB per 1000 ft @ 8 MHz 20 dB per 1000 ft @ 10 MHz 25 dB per 1000 ft @ 16 MHz 28 dB per 1000 ft @ 20 MHz</p>
NEXT	<p>Between 5 and 16 MHz NEXT>category limits (see below)+ 5dB (2 connector NEXT)</p> <p>Category 5 limits >48 dB @ 5 MHz >48 dB @ 8 MHz 47 dB @ 10 MHz 44 dB @ 16 MHz 42 dB @ 20 MHz</p>

B.2 Coaxial Cables

Following are the Pass/Fail limits used by the Scanner while testing coaxial cables.

Table B-6. 10BASE2 Pass/Fail Limits.

	Test Limit
Length	185 meters
Background Noise	400 mV peak
Characteristic Impedance	50+15 ohms
Termination Resistance	Characteristic Impedance \pm 15 ohms

Table B-7. RG58 Pass/Fail Limits.

	Test Limit
Length	185 meters
Background Noise	400 mV peak
Characteristic Impedance	50+15 ohms
Termination Resistance	Characteristic Impedance \pm 15 ohms

Table B-8. RG58 Foam Pass/Fail Limits.

	Test Limit
Length	185 meters
Background Noise	400 mV peak
Characteristic Impedance	50+15 ohms
Termination Resistance	Characteristic Impedance \pm 15 ohms

Table B-9. 10BASE5 Pass/Fail Limits.

	Test Limit
Length	500 meters
Background Noise	400 mV peak
Characteristic Impedance	50+15 ohms
Termination Resistance	Characteristic Impedance \pm 15 ohms

Table B-10. RG59 Pass/Fail Limits.

	Test Limit
Length	Not checked against length limit
Background Noise	400 mV peak
Characteristic Impedance	75+15 ohms
Termination Resistance	Characteristic Impedance \pm 15 ohms

Table B-11. RG59 Foam Pass/Fail Limits.

	Test Limit
Length	Not checked against length limit
Background Noise	400 mV peak
Characteristic Impedance	75+15 ohms
Termination Resistance	Characteristic Impedance \pm 15 ohms

Table B-12. RG62 Pass/Fail Limits.

	Test Limit
Length	Not checked against length limit
Background Noise	400 mV peak
Characteristic Impedance	93+15 ohms
Termination Resistance	Characteristic Impedance ± 15 ohms

Appendix C: Pinouts

C.1 Printer Connector

Figure C-1 shows a pin layout of the printer connector on the Scanner.

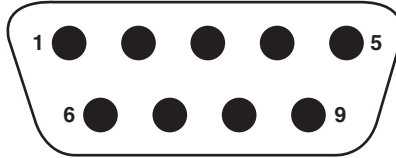

- 1 *no connection*
- 2 Receive Data (input)
- 3 Transmit Data (output)
- 4 Data Terminal Ready (output)
- 5 Signal Ground
- 6 *no connection*
- 7 *no connection*
- 8 Clear To Send (input)
- 9 *no connection*

Fig. C-1. Printer Connector Pinouts.

C.2 Serial Printer Cable

This cable is equivalent to a standard IBM AT serial printer cable.

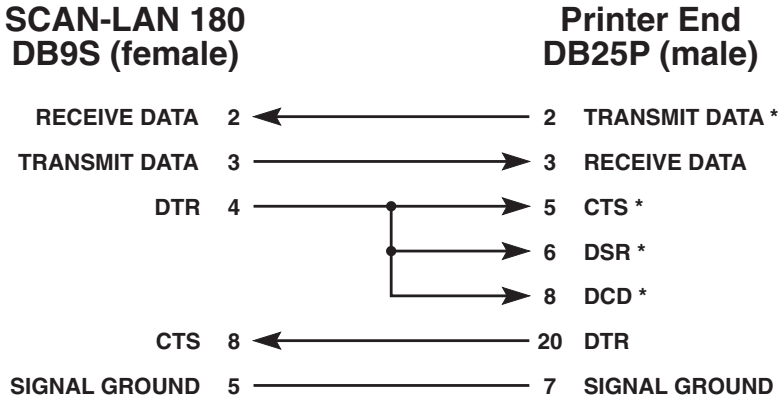

* Optional signals. Consult printer manual.

Fig. C-2. Serial Printer Cable Pinouts.

You may order the serial printer cable from your dealer.

C.3 RJ-45 Clip Lead Cable

Pin #	Wire Color	or	Pin #	Wire Color
1-----	Green		1-----	Orange
2-----	Red		2-----	Orange White
3-----	Black		3-----	Blue
6-----	Yellow		6-----	Blue White

Fig. C-3. RJ-45 Clip Lead Cable Pinouts.

NOTE

When using the RJ-45 clip- lead cable to measure unterminated cable, set the cable type to a 10BASE-T cable type (10BASE-T Cat 3-5) or use a custom cable type defined with an RJ-45 (10BASE-T) connector type.

Appendix D: Glossary

10BASE2—An IEEE standard for Thin Coax Ethernet networks—10-Mbps transmission, baseband signaling, 185 meters per coax segment. Also known as ThinNet or Cheapernet.

10BASE-T—An IEEE standard for unshielded twisted-pair Ethernet networks—10-Mbps transmission, baseband signaling, unshielded twisted-pair cable. Maximum allowable cable length is 100 meters.

Anomaly—An impedance discontinuity causing an undesired signal reflection on a transmission cable. *Inverted anomaly*—Reflection caused by a lower-impedance discontinuity, such as a short. *Non-inverted anomaly*—Reflection caused by a higher-impedance discontinuity, such as an open.

ARCNET—Acronym for Attached Resource Computer NETwork. A token-bus local area network standard developed by Datapoint Corporation. ARCNET runs on RG62 coax, twisted-pair, or fiberoptic cable with a basic signaling rate of 2.5 Mbps.

Attenuation—A reduction in the strength of a signal expressed in dB.

BNC—A coaxial cable connector, used with Thin-wire (10BASE2) Ethernet networks.

Characteristic Impedance—Resistance to AC current flow presented by a long cable. An AC parameter, not related to DC resistance.

Coax—Coaxial cable. A type of cable in which the inner conductor is surrounded by a tubular conductor, which acts as a shield. Coaxial cables typically have a wide bandwidth.

Collision—The result of two stations simultaneously attempting to transmit data, resulting in a runt packet.

Crossed Pair—A wiring error in twisted-pair cabling where a pair on one connector of the cable is wired to a different pair on the other end of the cable.

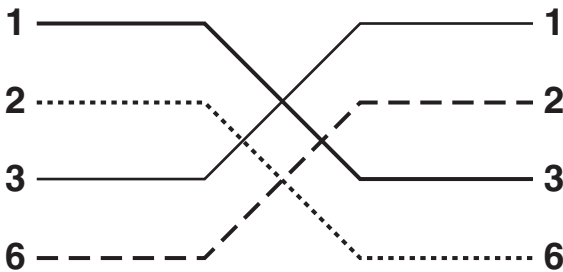

Fig. D-1. Crossed Pairs.

Crosstalk—Noise coupled between pairs of wire in twisted pair cable.

dB—Abbreviation for “decibel”—a logarithmic unit of measure expressing the amplitude ratio between two signals.

$$dB=20\log(V_{out}/V_{in})$$

EIA568—A wiring standard for commercial building telecommunications, established by the Electronic Industries Association. Specifies maximum cable lengths, installation practices, and performance specifications for generic building wiring.

Ethernet—A high-speed local area network using Carrier Sense Multiple Access with Collision Detection (CSMA/CD). Ethernet is available with four cabling alternatives: thin coaxial cable, standard (thick) coaxial cable, twisted pair, and fiberoptic cable.

Jabber—A network fault condition where one station is continuously transmitting data (for more than 20 milliseconds).

Link Pulse—A single bit test pulse transmitted by stations every 2-150 milliseconds during idle periods on 10BASE-T link segments. Used to verify link integrity.

NEXT—Near-end crosstalk; noise coupled between two twisted pairs measured at the same end of the cable as the disturbing signal source.

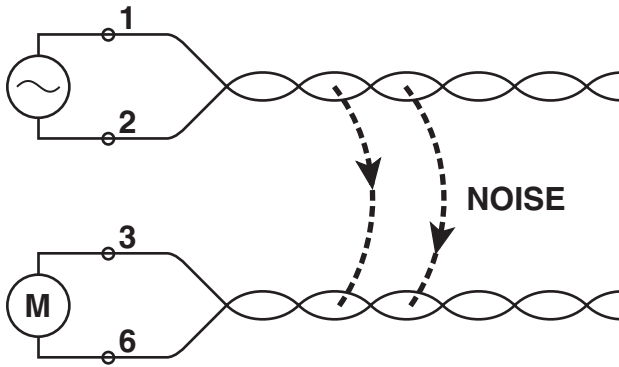

Fig. D-2. NEXT.

NVP—Nominal Velocity of Propagation—the speed of signal propagation through a cable, expressed as a percentage of the speed of light in a vacuum.

Open—A break in the continuity of a circuit, preventing signal transmission.

Packet—A group of bits in a defined format, containing a data message that is sent over a network.

Plenum cable—Cable that has been certified for installation in air ducts and open spaces over suspended ceilings without conduit. Plenum cable is fire-resistant and does not emit toxic fumes when burned.

Reversed Pair—A wiring error in twisted-pair cabling where the pins on a pair are reversed between connectors on each end of the cable.



Fig. D-3. Reversed Pair.

RJ-45—An 8-position telephone-type modular connector used with twisted-pair cable.

Runt Packet—An Ethernet data packet that is shorter than the valid minimum packet length (64 bytes). Usually caused by a collision.

Segment—A network cable terminated at both ends.

Shielded Twisted Pair—Twisted-pair cable encased in an outer metallic sheath. The sheath is grounded to shield the wire pairs from external noise.

Short—A near-zero-resistance connection between two wires of a circuit.

Signal/Noise Ratio—The ratio of received signal level to noise level, measured at the receiver input (expressed in dB). The S/N ratio may be expressed as NEXT (dB)-Attenuation (dB), provided idle channel background noise is low. Higher S/N ratios provide better channel performance.

Split Pair—A wiring error in twisted-pair cabling where a balanced circuit uses one wire from one pair and the other wire from a different pair. The cable may have correct pin-to-pin continuity between ends, but because the transmission circuit is split between two twisted pairs, excessive crosstalk occurs.

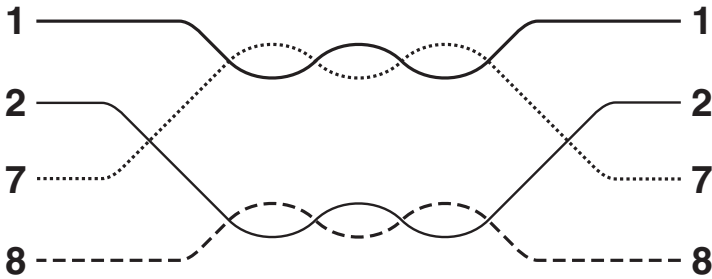

Fig. D-4. Split Pairs.

TDR—Time-Domain Reflectometry—a technique for measuring cable lengths by timing the duration between an incident test pulse and the reflected pulse from an impedance discontinuity on the cable (such as an open at the end of the cable). The length of the cable may be calculated by knowing the velocity of propagation of the pulse through the cable:

$$\text{length} = t/2t \times \text{NVP} \times C$$

where:

t =round-trip time between incident and reflected pulses

NVP=nominal velocity of propagation of electrical signals in the cable

C =speed of light in a vacuum

Terminator—A resistor connected to the end of a coax cable that is intended to match the characteristic impedance of the cable. Signals propagating down the cable are dissipated in the terminator, eliminating reflections from the end of the cable.

Token Ring—A local area network with ring topology, which uses token passing to control access.

Twisted Pair—A communication cable using a pair of wires that are twisted together. The twist reduces susceptibility to external interference.

10BASE-T, 6, 22, 36, 37, 39, 41, 57,
59, 64
10BASE2, 37
10BASE5, 37

A

Anomalies, 4, 18, 25, 26, 33, 63
Anomaly, 26, 45
Attenuation, 4, 5, 6, 10, 13, 17, 20,
22
Autotest, 5, 13, 17, 22, 24, 25, 27,
31, 42, 43, 61, 62, 63

B

Background Noise, 25
Bit rate, 43
BNC, 9, 12, 24, 48, 52, 53, 59

C

Cable Length, 5, 22
Calibrate Cable function, 56, 60
Characteristic Impedance, 13, 21,
25, 26, 59
Circuit Identifier, 61, 62
Coax, 37
Collisions, 38, 39, 41

D

dB, 87
DB9 connector, 42
DTR (hardware) flow control, 43

E

EIA/TIA 568, 4, 5, 6, 19, 20
Ethernet, 17

F

Fault threshold, 63

I

IEEE 802, 5
Impedance, 18

J

Jabber, 37, 39, 41

L

Length, 13, 17, 18, 22, 25, 26, 31,
33
LENGTH, 63
LINK, 41
Loopback mode, 20

M

Megohm, 52
Minimum fault threshold, 61
Minimum noise threshold, 61

N

Near End Crosstalk (NEXT), 4, 5,
6, 10, 13, 17, 19, 22
Noise, 13, 31, 34, 64, 68
Noise threshold, 64
Nominal Velocity of Propagation
(NVP), 11, 17, 32, 56, 57, 58, 59
Nonvolatile memory, 42, 58

O

Open, 14, 27, 54
Oscilloscope, 48, 49, 50

P

Parity, 43

R

RG-58, 37

RG-58 Foam, 37

RJ-45, 9, 24, 48, 58

RS-232 serial interface, 42

S

Serial printer cable, 9

Short, 14, 27, 55

T

Termination Resistance, 25, 26

Throughput, 39

Time-Domain Reflectometry

(TDR), 4, 48, 49, 52, 54

Token Ring, 6, 17, 22, 59

Traffic, 38, 39, 43

Traffic monitoring, 68

U

Utilization, 41

UTP, 48

W

Wire Map, 4, 13, 14, 22, 31



© Copyright 1993. Black Box Corporation. All rights reserved.

1000 Park Drive • Lawrence, PA 15055-1018 • 724-746-5500 • Fax 724-746-0746