

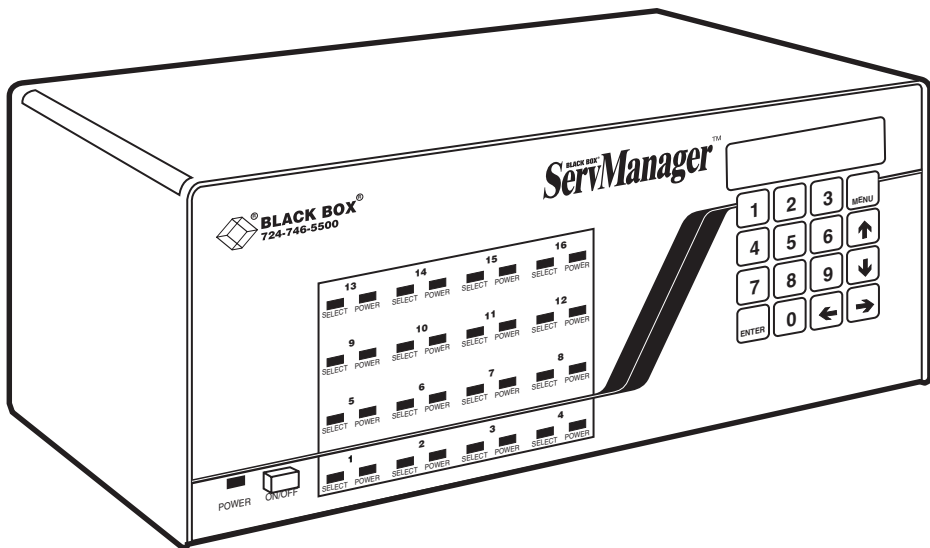

JULY 1997
SW995A-R2
SW995AE-R2
SW996A-R2
SW996AE-R2
SW997A-R2
SW997AE-R2
SW998A-R2
SW998AE-R2

ServManagers



**CUSTOMER
SUPPORT
INFORMATION**

Order toll-free in the U.S. 24 hours, 7 A.M. Monday to midnight Friday: 877-877-BBOX
FREE technical support, 24 hours a day, 7 days a week: Call 724-746-5500 or fax 724-746-0746
Mail order: Black Box Corporation, 1000 Park Drive, Lawrence, PA 15055-1018
Web site: www.blackbox.com • E-mail: info@blackbox.com



**FEDERAL COMMUNICATIONS COMMISSION
AND
INDUSTRY CANADA
RADIO FREQUENCY INTERFERENCE STATEMENTS**

This equipment generates, uses, and can radiate radio frequency energy and if not installed and used properly, that is, in strict accordance with the manufacturer's instructions, may cause interference to radio communication. It has been tested and found to comply with the limits for a Class A computing device in accordance with the specifications in Subpart J of Part 15 of FCC rules, which are designed to provide reasonable protection against such interference when the equipment is operated in a commercial environment. Operation of this equipment in a residential area is likely to cause interference, in which case the user at his own expense will be required to take whatever measures may be necessary to correct the interference.

Changes or modifications not expressly approved by the party responsible for compliance could void the user's authority to operate the equipment.

This digital apparatus does not exceed the Class A limits for radio noise emission from digital apparatus set out in the Radio Interference Regulation of Industry Canada.

Le présent appareil numérique n'émet pas de bruits radioélectriques dépassant les limites applicables aux appareils numériques de classe A prescrites dans le Règlement sur le brouillage radioélectrique publié par Industrie Canada.

NORMAS OFICIALES MEXICANAS (NOM) ELECTRICAL SAFETY STATEMENT**INSTRUCCIONES DE SEGURIDAD**

1. Todas las instrucciones de seguridad y operación deberán ser leídas antes de que el aparato eléctrico sea operado.
2. Las instrucciones de seguridad y operación deberán ser guardadas para referencia futura.
3. Todas las advertencias en el aparato eléctrico y en sus instrucciones de operación deben ser respetadas.
4. Todas las instrucciones de operación y uso deben ser seguidas.
5. El aparato eléctrico no deberá ser usado cerca del agua—por ejemplo, cerca de la tina de baño, lavabo, sótano mojado o cerca de una alberca, etc.
6. El aparato eléctrico debe ser usado únicamente con carritos o pedestales que sean recomendados por el fabricante.
7. El aparato eléctrico debe ser montado a la pared o al techo sólo como sea recomendado por el fabricante.
8. Servicio—El usuario no debe intentar dar servicio al equipo eléctrico más allá a lo descrito en las instrucciones de operación. Todo otro servicio deberá ser referido a personal de servicio calificado.
9. El aparato eléctrico debe ser situado de tal manera que su posición no interfiera su uso. La colocación del aparato eléctrico sobre una cama, sofá, alfombra o superficie similar puede bloquea la ventilación, no se debe colocar en libreros o gabinetes que impidan el flujo de aire por los orificios de ventilación.
10. El equipo eléctrico deber ser situado fuera del alcance de fuentes de calor como radiadores, registros de calor, estufas u otros aparatos (incluyendo amplificadores) que producen calor.
11. El aparato eléctrico deberá ser conectado a una fuente de poder sólo del tipo descrito en el instructivo de operación, o como se indique en el aparato.

12. Precaución debe ser tomada de tal manera que la tierra física y la polarización del equipo no sea eliminada.
13. Los cables de la fuente de poder deben ser guiados de tal manera que no sean pisados ni pellizcados por objetos colocados sobre o contra ellos, poniendo particular atención a los contactos y receptáculos donde salen del aparato.
14. El equipo eléctrico debe ser limpiado únicamente de acuerdo a las recomendaciones del fabricante.
15. En caso de existir, una antena externa deberá ser localizada lejos de las líneas de energía.
16. El cable de corriente deberá ser desconectado del cuando el equipo no sea usado por un largo periodo de tiempo.
17. Cuidado debe ser tomado de tal manera que objetos líquidos no sean derramados sobre la cubierta u orificios de ventilación.
18. Servicio por personal calificado deberá ser provisto cuando:
 - A: El cable de poder o el contacto ha sido dañado; u
 - B: Objetos han caído o líquido ha sido derramado dentro del aparato; o
 - C: El aparato ha sido expuesto a la lluvia; o
 - D: El aparato parece no operar normalmente o muestra un cambio en su desempeño; o
 - E: El aparato ha sido tirado o su cubierta ha sido dañada.

Contents

Chapter	Page
1. Specifications	7
2. Introduction	10
2.1 The Complete Package	10
2.2 Operating Features	10
2.3 The Front Panel	12
2.4 The Rear Panel	14
2.5 Cable Requirements	16
2.6 Equipment Requirements	16
3. Installation	17
3.1 Quick Setup Guide	17
3.2 Installation Procedure	18
3.3 Cascading in ServManager Systems	23
4. Operation	29
4.1 Guidelines for Using the ServManager with Your Equipment	29
4.2 Keyboard-Command Summary	36
4.3 The Commands in Detail	38
4.4 Using the Front-Panel Display and Keypad	54
4.5 Using the RS-232 Port	64
5. Troubleshooting	69
5.1 Diagnostic Information	69
5.2 Restoring Factory-Default Settings	70
5.3 Common Problems	71
5.4 Calling Black Box	77
5.5 Shipping and Packaging	77
Appendix A: NVRAM Factory Defaults	78
Appendix B: Product Codes for Cables	80
Appendix C: Error Messages	82
Appendix D: Pinout of RS-232 Port	83
Trademarks Used in This Manual	84

1. Specifications

- Compliance** — FCC Class A, DOC Class/MDC classe A
- Standards** — With original Serv cabling: VGA (color or monochrome/page white) video;
With original Serv cabling (minimal) or coaxial cabling (recommended): SVGA video;
With coaxial cabling: XGA (color or monochrome), Macintosh, or Sun video
- Interfaces** — CPU and MONITOR/KEYBOARD/MOUSE Ports:
Proprietary composite of:
 - IBM AT, IBM PS/2, Macintosh, or Sun keyboard;
 - RS-232, PS/2, ADB, or Sun mouse; and
 - Video (standards listed above);
RS-232 Port: Proprietary variant of EIA RS-232D using RJ-12 (“6-wire RJ-11”) connectors, DTE
- Resolution** — With original Serv cabling: Up to 1024 x 768 noninterlaced;
With coaxial or special cabling: Up to 1280 x 1024 noninterlaced
- Protocols** — RS-232: Asynchronous
- Data Formats** — RS-232: 8 data bits, 1 stop bit, no parity (fixed)
- Speed** — RS-232: 9600 or (for firmware update only) 57,600 bps
- Max. Distance** — Depending on the CPU, monitor, and video resolution (see **Section 4.1.3**), either:
25 ft. (7.6 m) of total original Serv cable from the keyboard, monitor, and mouse to any CPU, including up to 5 ft. (1.5 m) from any ServManager to any other Serv unit (submaster) attached to it; or
20 ft. (6.1 m) of coaxial cable—possibly as much as 100 ft. (30.5 m), depending on CPUs—from any ServManager to any device attached to it;

Max. Distance

(cont'd) — Also, 50 ft. (15.2 m) of serial cable from any ServManager's RS-232 port to a non-local computer

User Controls —

Keyboard commands;
Front-mounted ON/OFF pushbutton;
Front-mounted 16-key keypad;
On-screen menu (with optional overlay board
SW720C-R3 only)

Indicators —

All models: (1) Front-mounted 2 x 20 vacuum-fluorescent display panel;
SW995 models: (5) Front-mounted LEDs:
(1) POWER [unit], (2) SELECT, (2) POWER [CPU];
SW996 models: (9) Front-mounted LEDs:
(1) POWER [unit], (4) SELECT, (4) POWER [CPU];
SW997 models: (17) Front-mounted LEDs:
(1) POWER [unit], (8) SELECT, (8) POWER [CPU];
SW998 models: (33) Front-mounted LEDs:
(1) POWER [unit], (16) SELECT, (16) POWER [CPU]

Connectors —

All rear-mounted;
All models:
(1) 5-pin DIN female: POWER;
(1) RJ-12 female: RS-232 (for remote control);
(1) DB25 female: MONITOR/KEYBOARD/MOUSE;
SW995 models: (4) DB25 female: CPU;
SW996 models: (8) DB25 female: CPU;
SW997 models: (12) DB25 female: CPU;
SW998 models: (16) DB25 female: CPU;

Maximum Altitude —	10,000 ft. (3048 m)
Temperature Tolerance —	32 to 131° F (0 to 55° C)
Humidity Tolerance —	10 to 90% noncondensing
Enclosure —	Steel
Power —	<i>For 120-VAC, 60-Hz operation:</i> From wallmount power supply PS018: Optimal input: 117 VAC, 60 Hz, 400 mA; Output: 16.5 VAC CT, 1.45 amps; Consumption: Up to 23.9 VA; <i>For 230-VAC, 50-Hz operation:</i> From desktop power supply PS018E: Optimal input: 230 VAC, 50 Hz, 255 mA; Output: 16 VAC CT, 2.5 amps; Consumption: Up to 23.9 VA
Size —	5.5"H x 13.5"W x 4.9"D (14 x 34.3 x 12.4 cm)
Weight —	Net: 10 lb. (4.5 kg); Shipping: 12 lb. (5.4 kg)

2. Introduction

Your new ServManager will simplify your job by helping you organize your multiple-computer application. Because it lets you use one keyboard, monitor, and mouse to access and control a number of IBM® PC, Apple® Macintosh®, Sun Microsystems®, or compatible computers, you can significantly reduce your equipment overhead and end keyboard and monitor clutter.

The rest of this chapter describes everything that comes with the ServManager, the external and operating features of the ServManager, and the cabling you'll need for the ServManager.

2.1 The Complete Package

Your ServManager package includes the ServManager unit, its power supply, and this manual. If you didn't receive everything, or if anything arrived damaged, contact Black Box.

2.2 Operating Features

Some of the useful features of your ServManager:

- Access up to 256 IBM PC, Mac®, Sun®, or compatible CPUs with one keyboard, monitor, and mouse.*
- Microprocessor-controlled keyboard and mouse switching.
- Mouse can be PS/2®, Microsoft® serial, PC Mouse® (Mouse Systems®) serial, serial 8-bit, Apple, or Sun type.*
- Supports IBM, Apple, and Sun (Type 5 or higher) compatible keyboards, including all modes of IBM PS/2 and AT® compatible keyboards.*
- Supports Apple; Sun; SVGA; and color or monochrome XGA or VGA video at resolutions up to 1280 x 1024 noninterlaced (although all video types except VGA require coaxial or special cables).
- Select desired CPU from keyboard, front panel, or RS-232 port.

*Supported peripheral types will depend on the CPU types. Refer to **Section 3.2.2**.

- Front-panel LEDs show selected CPU and its power-on state; with the front-panel keypad and display, you can reconfigure the unit directly and visually verify current settings.
- Remembers and restores Num Lock, Caps Lock, Scroll Lock, and keyboard mode of each CPU when switching.
- Screen-save function turns off video after 1 to 999 seconds of inactivity.
- Scan function can sequence between CPUs every 1 to 999 seconds.
- You can program IBM keyboards' typematic rate and delay.
- Custom settings for each CPU can be saved in nonvolatile memory.
- Flash memory allows updating firmware through serial port.
- Optional daughterboard (our product code SW720C-R3) adds an on-screen menu. Call Black Box for details.
- Rackmount kits are also available.

2.3 The Front Panel

The ServManager’s front panel features one pushbutton switch, several LED indicators, a touch-activated keypad, and a vacuum-fluorescent display. To familiarize yourself with these controls and indicators, refer to Figure 2-1 below and the descriptions that follow.

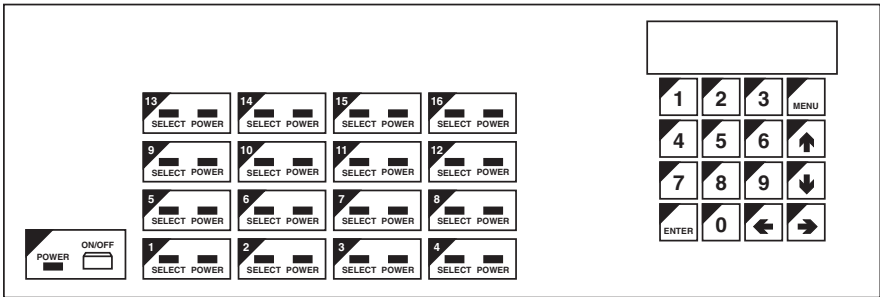

Fig. 2-1. The front panel of a 16 to 1 ServManager (SW998).

- POWER (left)** Power LED: Lights to indicate that unit is powered ON.
- ON/OFF** Power Button: Pressing this button turns the unit ON and OFF when the power supply is plugged into the unit and into a working outlet.
- CPU STATUS** CPU Status LEDs: Numbered pairs of LEDs indicate the statuses of the CPUs or submaster (cascaded) Serv devices connected to the corresponding ports on the rear panel:
 - SELECT (red)**
Lights if the corresponding port is the currently selected port.
 - POWER (green)**
Lights if the device on the corresponding port is powered ON.

NOTE

All models share the same chassis, which has 16 each of the SELECT and POWER slots. The extra LED slots in the chassis of the 4-, 8-, and 12-port models are left blank, but are protected by the chassis’ faceplate.

- DISPLAY** During normal operation, this two-line by twenty-character vacuum-fluorescent display shows the name and number of the currently selected CPU on the first line and the CPU's power status on the second line. When you access the MENU function on the keypad, other information will be displayed.
- KEYPAD** With this sixteen-key keypad, you can switch between CPUs sequentially (using the arrow keys) or directly (using the numeric and ENTER keys). Use the MENU key to view and change configuration settings.

2.4 The Rear Panel

All cable connections are made at the ServManager’s rear panel, as illustrated (in Figure 2-2) and described below.

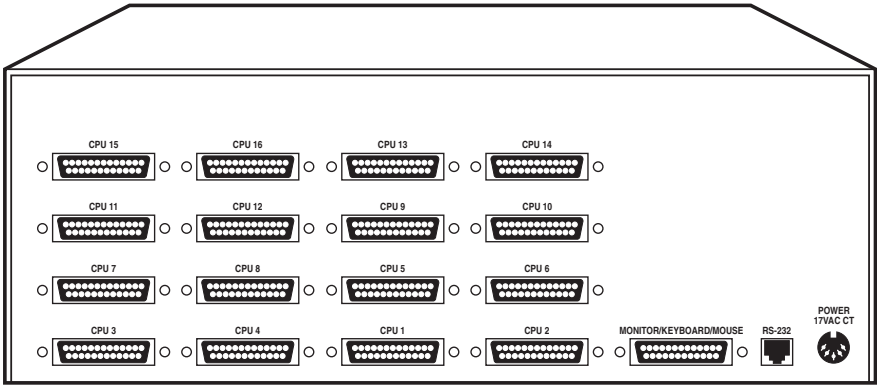

Fig. 2-2. The rear panel of a 1 to 16 ServManager (SW998).

Panel Label	Connector	Description
CPU <i>N</i> [<i>N</i> = a number from 1 to either 4, 8, 12, or 16, depending on which model you have]	DB25 F	Connect computers to these ports with “CPU Adapter Cables.” At the ServManager end, these cables have a DB25 male connector; at the other ends, they have appropriate connectors for plugging into your CPUs’ video, keyboard, and mouse ports. These cables take the signals that would normally pass between the CPUs’ ports and the monitor, keyboard, and mouse, and carry them between the CPUs’ ports and the ServManager instead. You can also connect “submaster” Serv type switches to these ports with “ServSwitch-to-ServSwitch Expansion Cables.” These cables have DB25 male connectors at both ends and carry all necessary signals from submaster units to master units.

Panel Label	Connector	Description
CPU <i>N</i> (continued)	DB25 F	For each submaster you plan to connect, you must have an Expansion Cable; you must have an Adapter Cable for each CPU you plan to connect. See Section 2.5 .
NOTE		
All models share the same chassis, which has 16 CPU <i>N</i> connector slots. The extra connector slots in the chassis of the 4-, 8-, and 12-port models are left blank, but are protected by material mounted inside the chassis.		
MONITOR/ KEYBOARD/ MOUSE	DB25 F	Connect the shared monitor, keyboard, and mouse to this port using an “MKM Adapter Cable.” At the ServManager end, this cable has a DB25 male connector; at the other ends, it has appropriate connectors to plug into your monitor, keyboard, and mouse cables. Only one MKM Adapter Cable is needed. See Section 2.5 .
RS232	RJ-12 F	If you connect a more distant computer or terminal to this RS-232 serial port, you’ll be able to send switching commands to the ServManager from a secondary location. You would also connect a computer to this port to load firmware upgrades into the ServManager.
POWER	5-pin DIN F	Connect the ServManager’s power-supply cord here. This is <i>not</i> a keyboard input. Power transformers are available for 110 VAC or 230 VAC. They have center-tapped output of 17 VAC at 1.4 amps.

2.5 Cable Requirements

To connect CPUs to the ServManager, you need one “CPU Adapter Cable” for each CPU. This cable reaches the CPU’s video-output, keyboard, and mouse ports.

Likewise, to connect “submaster” (slave) ServSwitches to the ServManager, you need one “ServSwitch-to-ServSwitch Expansion Cable” for each subsidiary unit.

Lastly, you can connect the ServManager to the shared monitor, keyboard, and mouse with a single “Monitor/Keyboard/Mouse (MKM) Adapter Cable.”

The exact variety or varieties of these cables that you’ll need will depend on the equipment you are connecting for your application. Refer to **Section 4.1** for information on equipment that requires special cables, and to **Appendix B** for the available types of stock cables and the corresponding product codes. Also refer to **Chapter 1** or the first Caution notice on page 19 for information about maximum cabling distances.

NOTES

SVGA (over longer distances) and XGA video place special demands on cabling that the regular MKM Adapter Cables and CPU Adapter Cables typically cannot meet. For these applications, you should use coaxial cables that can carry video signals not only farther but also at higher resolutions. See Appendix B and the first Caution notice on page 19.

To share a 9515, 9517, or 9518 monitor, you will need special cabling. Call Black Box for technical support; we can give you a quote on these types of cable.

2.6 Equipment Requirements

If the CPUs you are controlling through the ServManager are not all of the same type—especially if they are completely different hardware platforms (IBM, Mac, etc.)—you will have to be careful to choose a common monitor, keyboard, and mouse that adequately support all of the CPUs. For full details, see **Section 4.1**.

3. Installation

3.1 Quick Setup Guide

Figure 3-1, below, shows a basic example of connecting a CPU, a submaster, a keyboard, a monitor, and a mouse to a ServManager unit. IBM PC equipment is shown, but the basic principles will be similar for all equipment types. Connectors will vary depending on the types of equipment you are installing.

Fig. 3-1. Basic system setup for a 16-port (SW998) unit.

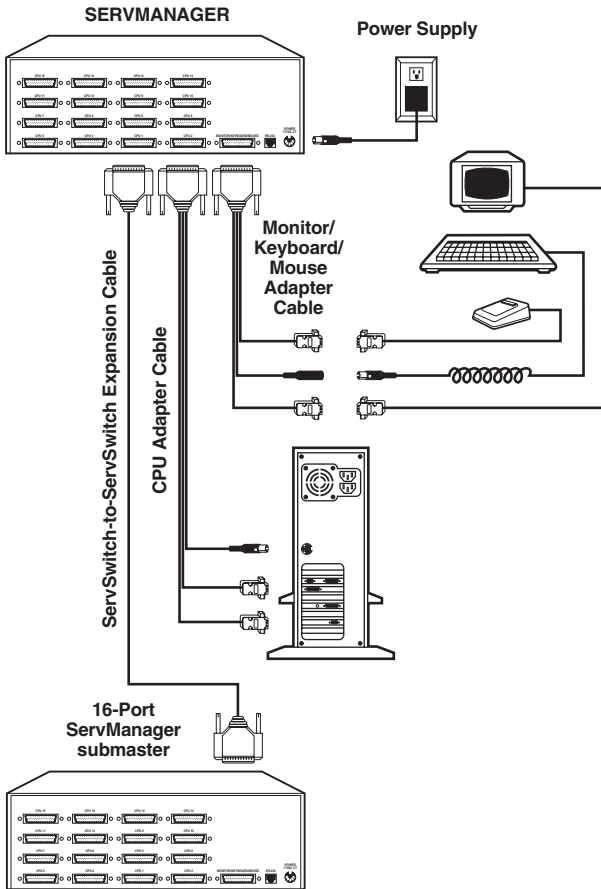

3.2 Installation Procedure

This section provides complete basic instructions for the hardware setup of a single ServManager. (For detailed instructions on the capabilities and concerns involved in installing a cascaded ServManager system, see **Section 3.3**; to make troubleshooting the installation easier, we recommend that you check the master and each submaster as it is installed, rather than installing all units, then checking the entire cascade.) For an illustrated example of the elements of a basic setup, see Figure 3-1 on the previous page.

3.2.1 RACKMOUNTING (OPTIONAL)

If you want to mount the ServManager in a 19" rack, you will need a ServSwitch Rackmounting Kit (our product code SW728). The ServManager is pre-drilled to accept the Kit's rackmounting screws. If you want to mount the ServManager in a 23" or 24" rack, call Black Box Technical Support for a special quote on a 23" or 24" Kit.

3.2.2 CONNECTING THE MONITOR, KEYBOARD, AND MOUSE

A Monitor/Keyboard/Mouse (MKM) Adapter Cable connects your monitor, keyboard, and mouse to the ServManager. Because various styles of electrical connectors are used by different classes of equipment, we supply this cable in various styles to match (see **Appendix B**). This cable also comes in the different lengths supported by different applications (see **Section 4.1.3**, **Appendix B**, and the first Caution notice on the next page).

CAUTION!

Make sure that your monitor, keyboard, and mouse can meet the demands of your application. You might also need a special MKM Adapter Cable if you are mixing platforms. See Section 4.1. Also, note that the ServManager does *not* support dongles at the time of this writing.

1. After you verify that the ServManager is turned OFF, plug the DB25 male connector of the MKM Adapter Cable into the port labeled MONITOR/KEYBOARD/MOUSE on the ServManager's rear panel.
2. If your common equipment is IBM type, plug the cables from your shared monitor, keyboard, and mouse into the corresponding connectors on the other ends of the MKM Adapter Cable. If your common equipment is Mac or Sun type, plug the mouse cable into the keyboard, and plug the monitor and keyboard cables into the corresponding connectors on the other ends of the MKM cable.

3.2.3 CONNECTING CPUs

CPU Adapter Cables run from the ServManager to the keyboard port, mouse port, and video-output port of each CPU you want to directly attach to it. Different types of this cable fit the connectors on different computers (see **Appendix B**). This cable also comes in the different lengths supported by different applications (see **Section 4.1.3**).

CAUTION!

Avoid routing cable near fluorescent lights, air-conditioning compressors, or machines that may create electrical noise. Total length of original Serv cable from the keyboard, monitor, and mouse to any given CPU should not exceed 25 ft. (7.6 m). For typical equipment and video resolutions, length of coaxial cable should not exceed 20 ft. (6.1 m) from a ServManager to any attached device (keyboard, monitor, mouse, CPU, or submaster). However, we do provide coaxial cable in lengths up to 100 ft. (30.5 m), because some CPUs can drive and receive keyboard and mouse signals at greater distances than others; consult with the manufacturers of your CPUs about this. To go even farther, you might want to use Station Extenders (see Appendix B) if your common keyboard and mouse are IBM type.

1. After you verify that the ServManager is turned off and unplugged, plug the DB25 male connector of the first CPU's CPU Adapter Cable into the lowest-numbered CPU port on the ServManager's rear panel that isn't going to be occupied by a submaster Serv type switch. Use consecutively higher-numbered ports for the rest of the CPUs. For example, if you planned to put three submasters and three CPUs on an 8-port master ServManager, you would put the submasters on ports CPU 1 through CPU 3 (see **Section 3.2.4**), and you would plug the three CPUs into ports CPU 4 through CPU 6.
2. Plug the CPU Adapter Cable's video-, keyboard-, and mouse-port connectors into the corresponding ports on the CPU. The CPU should be OFF when you do this; the ServManager will automatically adjust to the keyboard mode of IBM compatible CPUs when you power up the CPU. Avoid plugging CPUs into the ServManager if they are already ON; if you accidentally do so, see **Section 4.3.7** to make sure the ServManager is set for the proper keyboard mode.

CAUTION!

Do not attach docking stations for ThinkPad® or other portable computers, no matter what type or make, to the ServManager. At the time of this writing, the ServManager does not support docking stations; your ServManager system might not function properly if any are attached.

3.2.4 CONNECTING SUBMASTERS (OPTIONAL)

To connect a submaster ServManager, Matrix ServSwitch, original ServSwitch, etc., to a master ServManager, run a ServSwitch-to-ServSwitch Expansion Cable (our product code EHN055 for original cable or EHN274 for [recommended] coaxial cable) from one of the master ServManager's CPU ports to (one of) the submaster's MONITOR/KEYBOARD/MOUSE port(s). Connect the first submaster to the ServManager's CPU 1 port and use consecutively higher-numbered ports (CPU 2, CPU 3, and so on) for the rest of the submasters. If you are connecting each of several Matrix ServSwitches to two master ServManagers (see **Section 3.3**), connect one master to each Switch's MONITOR/KEYBOARD/MOUSE A port and the other master to each Switch's MONITOR/KEYBOARD/MOUSE B port.

Before installing an advanced configuration, please call Black Box and discuss your application with a technician.

NOTE

Because ServManagers don't have bus-mouse ports and can't carry the bus-mouse signal, they can't function adequately as masters for submaster ServSwitches BusM.

3.2.5 CONNECTING THE SERVMANAGER'S POWER SUPPLY

Making sure the connected CPUs and any connected submasters are OFF (powered down), take the output cord of the ServManager's power supply and plug its 5-pin DIN male connector into the power jack on the rear panel of the ServManager. Plug the power supply (115 VAC) or its input cord (230 VAC) into a working outlet.

3.2.6 CONFIGURING THE SERVMANAGER

Unless you are using an IBM PC style keyboard and a PS/2 mouse as the common keyboard and mouse, are using all IBM PC type CPUs, and are not cascading, you will have to configure the ServManager. To do so, use its front-panel display and keypad:

1. Push the ON/OFF button on the front of the ServManager to power up the unit, and wait for a few seconds for the unit to complete its power-up procedure. The display should show the firmware revision and some diamonds as it performs its power-up tests, then should connect the keyboard, monitor, and mouse to the CPU on port CPU 1. The default name "CPU 1" should be shown on the first line of the display, and that CPU's power status should be shown on the second line.

2. Press the MENU key to access the configuration menu. A configuration option will appear; the order in which options appear will depend on the revision level of the unit's firmware. Press the up-arrow to cycle through the available options. When you reach the Max Ports option, enter the maximum number of ports in your system if it will differ from the displayed default.
3. Press the up-arrow until you get to the Keyboard option. Press the ENTER key to access the available settings for the Keyboard option. Use the up-arrow to scroll through the choices of PC, Mac (Apple), or Sun. Use the ENTER key to select the proper setting once you've scrolled to it. The selected setting should now appear on the top line.
3. If you are using a PC keyboard but are not using a PS/2 mouse, press the up-arrow again. The Mouse option should appear (at the time of this writing, "PS/2" is the default). Press the ENTER key to access the available settings for the Mouse option. Use the up-arrow to scroll through the available choices (see **Section 4.4.2.E**). Use the ENTER key to select the proper setting once you've scrolled to it. The selected setting should now appear on the top line.
4. If not all of your CPUs are IBM PC type, press the up-arrow again. The CPU Keyboard/Mouse option should appear. Press the ENTER key to access the available settings for the this option. Use the arrow keys to scroll through the available choices for each CPU (see **Section 4.4.2.F**). Use the ENTER key to select the proper setting once you've scrolled to it. The selected setting should now appear on the top line. To exit this option, press the MENU key.
5. If you are cascading, press the up-arrow until you get to Width, then Units, setting each in turn. See **Sections 4.4.2.I** and **4.4.2.J**.
6. Use the menu key to exit the menu. You are prompted to save the configuration menu. Press the ENTER key to save the new keyboard setting. Power the unit OFF.

3.2.7 POWERING UP THE SYSTEM

1. Push the ON/OFF button on the front of the ServManager to power up the ServManager.
2. Power up the directly connected CPUs and any connected submasters one by one, giving each CPU time to boot completely before turning ON the next one. When the CPUs are powered up after the ServManager, the ServManager emulates all keyboard and mouse functions for automatic boot-up, although you might have to issue the Mode command **Mn** (see **Section 4.3.7**) to get proper keyboard communication.
3. Power up any CPUs connected to submasters one by one, giving each CPU time to boot completely before turning ON the next one.

3.2.8 SWITCHING BETWEEN CPUs

Your ServManager is now ready for operation using its default settings. To take full advantage of the ServManager's features, refer to **Chapter 4**; it gives detailed information about the ServManager's front-panel keypad/ display and the ServManager's keyboard commands, describing each command's function and keystroke sequence. (For your convenience, the keyboard-command information is summarized in **Section 4.2**.)

It's fairly simple to begin switching immediately, however.

- If you are switching from your keyboard, just press and release the keyboard's left Control Key ([CTRL]), then—within the next two seconds—type in your desired port number with the regular number keys (*not* the numeric keypad). (This procedure is slightly more complicated if there are more than nine CPUs in your ServManager system; refer to **Section 4.3.1**.)
- If you are switching from the ServManager's front panel, use the up- and down-arrow keys on the keypad to sequence through the CPUs, or use the number keys to type in the port number of a specific CPU and either press the ENTER key to switch to that CPU immediately, or wait two seconds and the ServManager will switch automatically. Selected CPUs' names, numbers, and power status will appear in the display.

3.3 Cascading in ServManager Systems

In a normal cascaded ServManager system, the shared monitor(s), keyboard(s), and mouse (mice) are directly attached to one or more “master” ServManagers, while all the CPUs are indirectly attached through “submasters” (other ServManagers, Matrix ServSwitches, original ServSwitches, etc.) that provide port expansion but may or may not perform any control functions of their own. When you cascade in this way, you can expand your system to include up to 256 ports (sixteen 16-port submasters on a 16-port master unit).

CAUTION!

If you use any ServSwitch or Matrix ServSwitch units as submasters, do not attach any CPUs to them that are not IBM PC compatible; these CPUs must output VGA video and must support either PS/2 or serial mice. All of the CPUs attached to any submaster must support the same type of keyboard and mouse.

Submasters can be added to your ServManager system as you need them. For each submaster you add to the system, you add as many ports as are on that submaster, minus one port on each ServManager “above” it that’s now occupied. Refer to Figure 3-2 on the next page:

- Connecting one 4-port submaster to a 4-port master ServManager (top view) gives you a total of 7 ports: 4 on the submaster and another 3 (4 minus the one that the submaster is attached to) on the master.
- Connecting four 4-port submasters to a 4-port master ServManager (bottom view) gives you a total of 16 ports, 4 on each submaster. (All 4 ports on the master are now occupied.)

When you use Matrix ServSwitches as submasters, the setup is a little more complicated. Refer to Figure 3-3 on page 25: Connecting two 4-port Matrix ServSwitch submasters to a 4-port ServManager gives you a total of 10 ports on that ServManager. (Each of the ServManagers in Figure 3-3 can access 10 ports, but CPU 9 and CPU 10 on either ServManager can only be accessed by the monitor, keyboard, and mouse on that ServManager.) Adding a third 4-port submaster unit gives you a total of 13 ports, and so on.

3.3.1 CABLE REQUIREMENTS FOR EXPANSION

To connect submaster units to a ServManager, you’ll need one ServSwitch-to-ServSwitch Expansion Cable for each submaster unit. You will also need a CPU Adapter Cable for each CPU you will be connecting to the submaster’s CPU ports. (Remember that one MKM Adapter Cable is required to connect the ServManager to your keyboard, monitor, and mouse.) See **Sections 3.2.2 through 3.2.4**.

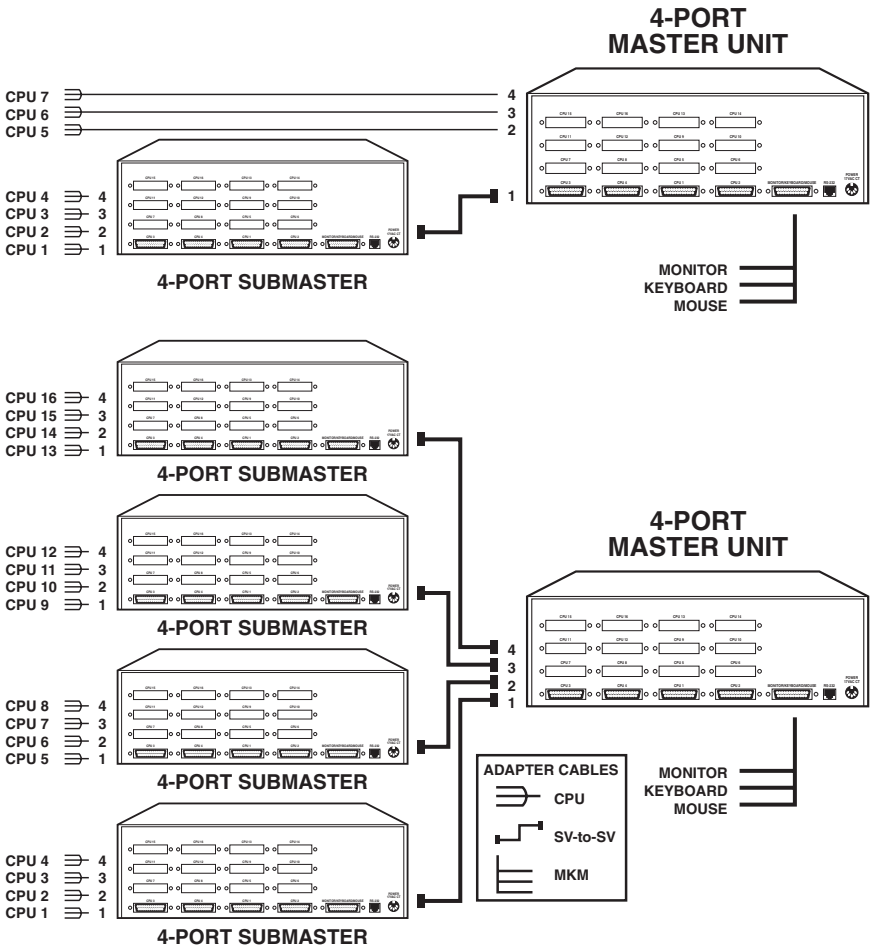

Fig. 3-2. Basic ServManager cascading.

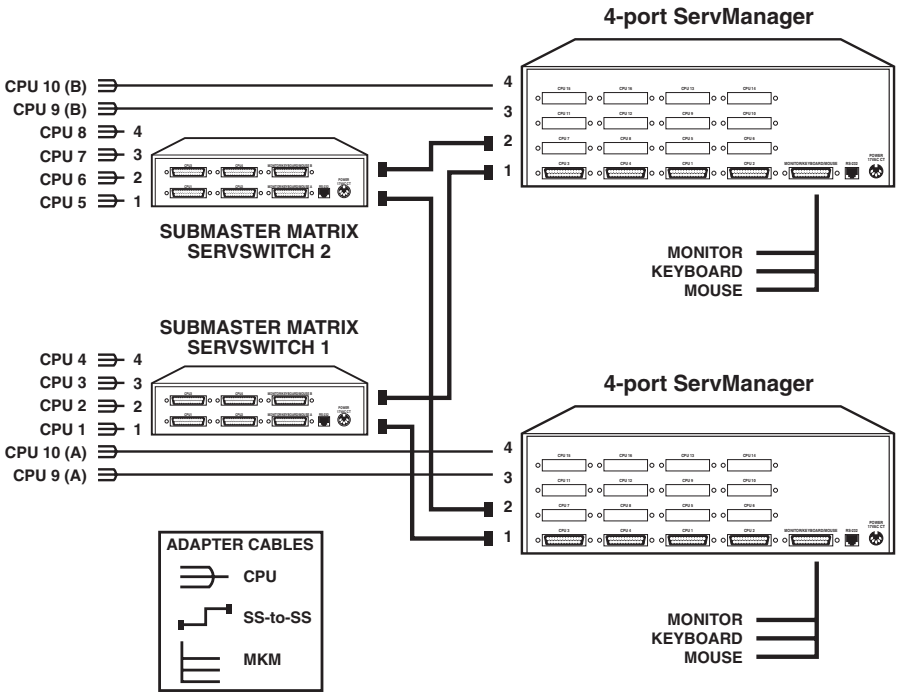

Fig. 3-3. Cascading 4-port Matrix ServSwitches with 4-port ServManagers.

3.3.2 INSTALLING A CASCADE

Laying out your ServManager system prior to installation will make the installation process go more smoothly. It will also help you to keep the port-selection numbers you'll use in keyboard commands in a rational sequence. Figure 3-2 on the previous page and Figure 3-3 above illustrate the proper layout and numbering of your submasters and CPUs.

Keep these restrictions in mind when you design your ServManager system:

- If you use original Serv cables, the total distance from any CPU to any monitor, keyboard, and mouse should not exceed 25 ft. (7.6 m). Depending on your application, this distance might be less; see Section 4.1.3.

- If you use coaxial cables, the maximum recommended distance from the ServManager to the attached monitor, keyboard, and mouse is 20 ft. (6.1 m) with typical monitors and video resolutions, but see the first Caution notice on page 19. For typical CPUs, this is also the maximum recommended distance from any submaster to any attached CPU. Depending on your application, this distance might vary; see **Section 4.1.3**.
- The distance between any ServManager and any submaster plugged into one of its ports must not exceed 20 ft. (6.1 m) of original Serv cable. For coaxial cable, the maximum recommended distance is 20 ft. (6.1 m), but see the first Caution notice on page 19.
- The total number of CPU ports accessible by any ServManager master unit must not exceed 256.
- You must not use older (“-R2” product code or earlier) 2- or 4-port (SW721 or SW722 model) ServSwitches as submasters. Their cascading logic and command language is different from that of all other Serv type units.
- You must not cascade submasters to more than one “layer.” That is, you may connect submasters to the CPU ports of one or two ServManagers, but do not connect any submasters to *submasters’* CPU ports. To illustrate this restriction, let’s say you’ve installed a four-port submaster on a four-port ServManager and you have a four-port submaster yet to install. You must install the second submaster on the ServManager’s CPU 2 port, not on the first submaster’s CPU 1 port. A third submaster would have to go on the ServManager’s CPU 3 port, a fourth on the CPU 4 port. If it becomes necessary to attach more CPUs after “maxing out” on submasters, you must upgrade your ServManager or submasters.
- If you are attaching more than one submaster to a master ServManager, we strongly recommend that all of the submasters have the same number of ports. This is because the ServManager’s Width command/parameter—the value it uses to calculate how many ports each attached submaster has (see **Section 4.3.9**)—is *global* rather than *port-specific*. In other words, a master ServManager always expects *every* submaster attached to it to have the number of ports specified in Width.

For example, if you attach one 4-port submaster and one 8-port submaster to a master ServManager, then set Width to 4 (and Units to 2 and Max Ports to 12—see **Sections 4.3.8** and **4.3.10**), you will be unable to scan or switch to the upper 4 ports on the 8-port submaster—the ServManager has no way of knowing they are even there. On the other hand, if you set Width to 8 (and Units to 2 and Max Ports to 16), your system will include 4 “phantom” ports (nonexistent ports 5 through 8 on the 4-port submaster) that the ServManager will think are there and will try to scan or switch to, displaying a blank screen.

When you’re ready to begin hooking up the actual units, follow these steps:

1. If this hasn’t already been done, connect the monitor(s), keyboard(s), and mouse (mice) to the MONITOR/KEYBOARD/MOUSE port(s) of your master device(s) as outlined in **Section 3.2.2**.
2. Use ServSwitch-to-ServSwitch Expansion Cables (see **Section 3.2.4**) to connect all the submaster units to the CPU ports of your master(s), beginning with the master port labeled CPU 1 and continuing with CPU 2, CPU 3, etc. (Avoid installing submasters with different numbers of CPU ports on the same master; if possible, every Serv unit in your cascade should have the same number of ports.)
3. Using CPU Adapter Cables, attach your computers to available CPU ports: the first computer to the port identified as CPU 1, CPU #2 to its port, etc. (see **Section 3.2.3**). The computers should all be OFF; do *not* turn them ON yet.
4. Attach the power supplies to the master(s) and to the submasters. Plug in the power supplies, but do *not* turn the master(s) or submasters ON.
5. Turn ON all of the submaster units, then the master unit(s).
6. Turn ON the computer identified as CPU 1. Wait until the boot process is complete, then turn ON CPU 2, wait until it boots, turn ON CPU 3, etc., until all of your computers are powered up.

(continued on next page)

NOTE

In the next three steps, “[CTRL]” represents pressing and releasing the left Control Key, “[ENTER]” represents pressing and releasing the Enter or Return Key, and “xxx” represents a number consisting of one to three ASCII digits.

7. Set each master’s Units, Width, and Maximum Ports values, so that it can scan correctly and properly control the interplay of the submaster units. On ServManager masters, you can do this with the front-panel keypad and display (see **Section 4.4**), or you can send these keyboard commands (see **Sections 4.3.8** through **4.3.10**):
 - The Units command, to tell the master how many submasters there are: [CTRL] Uxxx [ENTER]
 - The Width command, to tell the master how many CPU ports are on each submaster: [CTRL] Wxxx [ENTER]
 - The “Maximum Ports” command, to tell the master the total number of ports available in the system: [CTRL] Pxxx [ENTER]
8. You might need to set any or all of each master’s remaining configuration parameters, especially the keyboard mode for some of your ports. To do this with the keypad and display, see **Section 4.4**; to do this with keyboard commands, see **Sections 4.3.4** through **4.3.7** and **4.3.11**.

NOTE

Configuring a master ServManager while submaster ServManagers are attached automatically configures the submasters as well; they disable their own front-panel configuration functions when they detect their submaster status. If you attach submaster ServManagers after configuring a master ServManager, cycling through the master’s entire front-panel configuration menu will automatically configure them.

9. To save the “Units,” “Width,” and “Maximum Ports” numbers you entered to the master unit’s nonvolatile memory, along with any of the other configuration settings you might have changed, enter the “Keep Settings” command, [CTRL] K [ENTER].

Your cascaded ServManager system should now be ready for operation.

4. Operation

The first part of this chapter, **Section 4.1**, gives you some guidelines that you should follow to make sure your ServManager works properly with your equipment. **Section 4.2** summarizes the ServManager's keyboard commands, and **Section 4.3** describes these commands in detail. **Section 4.4** details how to use the ServManager's front-panel keypad and display. **Section 4.5** describes a complex application that illustrates the ServManager's flexibility. **Section 4.6** outlines how you can select ports or upgrade firmware from an optional computer or terminal connected to the ServManager's RS-232 port.

NOTES

With the optional overlay board SW720C-R3 installed, your ServManager can be controlled through an on-screen menu. Call Black Box for details.

To start any ServManager keyboard command, you must press and release the left Control Key ([CTRL]). Pressing and releasing [CTRL] cues the ServManager to expect command characters from the keyboard. You then have two seconds in which to start entering a valid command. If no command is begun within two seconds or if an invalid command is entered, the ServManager aborts the command.

When entering commands that contain numbers or math symbols, use only the numeral keys located at the top of your alphanumeric keyboard. Numbers and symbols entered from the numeric keypad to the right will not be recognized as valid.

4.1 Guidelines for Using the ServManager with Your Equipment

4.1.1 CPUs

- IBM type: Use only IBM AT or PS/2 or 100% compatible machines. The ServManager does not support IBM PC/XT™ or compatible machines.
- Apple or Sun type: Since the basic hardware design has remained backward-compatible for these CPUs, the ServManager supports all Apple and Sun machines.

4.1.2 MOUSE AND KEYBOARD

When you power up your ServManager system, make sure that your CPUs, mouse (mice), and keyboard(s) are properly cabled to the ServManager (or to the appropriate master or submaster unit). When you boot up the CPUs, the ServManager(s) and/or submasters to which they are connected should already be ON. Unless it's absolutely necessary, don't disconnect and reconnect a mouse or keyboard from a ServManager while the ServManager is ON; if you *have* to do this, issue the Reset command ([CTRL] R—see **Section 4.3.10**) after you reconnect the mouse or keyboard.

Though the ServManager can convert any supported keyboard or mouse protocol to any other, this is not enough to overcome all of the vast differences between input devices. If all of your CPUs are of the same type, we recommend that you use the corresponding type of keyboard and mouse. If your CPUs are of different types, certain limitations tend to favor the use of certain keyboard and mouse types:

Standard PC keyboards have 101 keys; standard Apple keyboards have 105 keys; and standard (Type 5 or higher) Sun keyboards have 118 keys as well as keyclick and beep features. We have mapped several of the “extra” Apple and Sun keys to the PC keyboard (see Table 4-1 on page 32), but many of the Sun keys simply cannot be mapped to IBM or Apple keyboards. Similarly, standard Apple mice have one button; standard PC mice have two or three buttons; and standard Sun mice have three buttons. At this time there is no way for a one- or two-button mouse attached to the ServManager to emulate a mouse with more buttons.

For these reasons, we recommend that you use Sun Type 5 or higher keyboards and Sun mice for mixed-platform applications that include Sun CPUs. For applications that include IBM and Apple CPUs but no Sun CPUs, we recommend that you use IBM keyboards and mice, because the IBM keyboard can emulate all of the Apple keyboard functions, but the one-button Apple mouse simply can't effectively operate IBM applications that lean heavily on the center or right mouse button.

Other concerns:

- The ServManager supports a variety of IBM PC type mice; for more details, see **Section 4.3.6**.

- If you are using a PC mouse as the common mouse, make sure that the IBM PC CPUs use only the generic Microsoft mouse driver `MOUSE.COM`, version 4.0 at least and preferably version 9.01 or higher. If you're running Windows®, this driver must be loaded in Windows as well as in the base operating system. Do not, on any of your switched IBM PC CPUs, run any programs or TSRs, or enter any DOS commands, that change the settings of the mouse port after the driver has been loaded.
- When you first switch between CPUs, especially CPUs of different platforms, you might notice wide variations in mouse sensitivity (how far or fast the mouse moves) from CPU to CPU. This is normal. All three of the major platforms supported by the ServManager (IBM, Apple, and Sun) have ways to adjust the sensitivity of the mouse. (This is usually handled through some kind of software “control panel,” but the specifics vary depending on the operating system and [in IBM applications] on the mouse driver.) To optimize mouse movement, adjust the sensitivity on each CPU according to your individual preference.
- Although the ServManager resists minor transient surges that can be caused by rapidly cycling power, certain keyboards are sensitive to such transients. Since your shared keyboard's power is provided by the ServManager, wait at least three seconds after powering down the ServManager before powering it up again, or the keyboard might not reset correctly.
- For IBM applications, the ServManager is designed to support IBM PC compatible 101-key keyboards and IBM PC keyboard-scan modes 1, 2, and 3, and it's designed to work with PC-type CPUs/keyboards that use 5-pin DIN or 6-pin mini-DIN keyboard connectors. The ServManager might not work properly with PC-type keyboards that have proprietary keys or connectors or use proprietary keyboard-scan modes.
- For Sun applications, if your Sun CPUs are looking for an older (Type 3) keyboard or a keyboard language other than standard US, you will have to set the Sun keyboard type or language with the front-panel display and keypad (see **Section 4.4.2.L**); there is no keyboard command to do this. Note that all of your Sun CPUs must be able to accept this single Sun keyboard type/language setting.

Table 4-1. Keyboard Mapping

Generally, the ServManager interprets keys by their positions on the keyboard, so any keys that occupy more or less the same positions and perform more or less the same functions across platforms will map one-to-one. However, certain keys available on certain keyboards do not correspond well or are not available on other types of keyboards, so the ServManager maps the more important of these as shown below.

On the Sun Keyboard, the: Control key Alt key Command (◆) keys Compose key Alt Graph key Power (○) key	Emulates the PC Keyboard's: Left Ctrl key Left Alt key N/A Right Alt key Right Ctrl key N/A	Emulates the Apple Keyboard's: Control keys Option (alt) keys Command (⌘) keys Option (alt) keys Control keys Power (⏻) key
On the IBM Keyboard, the: Left Ctrl key Left Alt key Right Alt key Right Ctrl key	Emulates the Apple Keyboard's: Control keys Command (⌘) keys Option (alt) keys Power (⏻) key	(Should not be used to emulate the Sun keyboard.)
On the Apple Keyboard*, the: Control keys Option (alt) keys Command (⌘) keys Power (⏻) key	Emulates the PC Keyboard's: Ctrl keys Alt keys N/A N/A	(Should not be used to emulate the Sun keyboard.)

*You should not use the Apple keyboard to emulate an IBM keyboard unless the operating systems and applications running on your system's IBM CPUs do not require the right mouse button and do not differentiate between left and right Ctrl and Alt keys.

4.1.3 MONITOR

NOTE

No keyboard/video switch can provide perfect video. You will see at least a little fuzziness on your monitor no matter how close to ideal your ServManager system is.

If all of your CPUs are of the same type, we recommend that you use the corresponding type of monitor. If your CPUs are of different types, the monitor *must* be a multisync model, able to sync to every CPU's video-output frequencies, and compatible with all of the CPUs' video cards. Also, while PC-type CPUs and VGA monitors normally use two separate leads to send/receive sync signals, one lead for horizontal sync and one for vertical sync, Mac and Sun CPUs/monitors normally send/receive a composite sync signal on a single lead. This means that either your monitor *must* be capable of accepting both H/V and composite-sync input, or you will have to use a sync converter and special cables to convert H/V to composite sync or vice versa (call Black Box Technical Support for a special quote).

For maximum compatibility, we recommend a 17" or larger, high-quality multisync monitor capable of (a) displaying a maximum resolution of not less than 1280 x 1024 at a maximum refresh rate of not less than 75 Hz, and (b) accepting both relevant types of sync input (H/V and composite). The NEC Multisync 5SG is one such monitor, and others are available from NEC, Sony®, CTX®, etc. (However, since these monitors usually have a DE15 [also called "DB15HD" or "HD15"] video-input connector, you will need a special M/K/M Adapter Cable to use them with Mac or Sun keyboards and mice—call Black Box Technical Support for a special quote.) The higher the resolution you use, the less distance you can run; see Tables 4-2 and 4-3 on the following pages.

Other concerns specific to IBM PC systems:

- The ServManager is designed to support standard VGA video, including VGA monochrome ("page white"). It does not support PCs that use proprietary versions of VGA that depart from the original specifications. Consult your PC's manual, and if that doesn't tell you whether or not the PC uses standard VGA, consult with the PC's or the video card's manufacturer.
- The ServManager is also designed to support SVGA, although it doesn't handle higher resolutions or longer distances very well without coaxial cabling (see the next two pages). With coaxial cables, it will also support XGA.

The ServManager will support SVGA (Super VGA) video, but with the original Serv cables for IBM PC applications, the video quality will decrease markedly at higher resolutions and distances. Table 4-2, below, illustrates this. The distances in the table are total cable lengths measured from the CPU to the monitor. The table assumes that one ServManager is between the CPU and monitor; in a cascaded application with a ServManager and a submaster between the CPU and monitor, video quality will always be lower.

Table 4-2. Video Quality vs. Distance for Original Serv Cables

Resolution \ Distance	5' (1.5 m)	10' (3 m)	15' (4.6 m)	20' (6.1 m)	25' (7.6 m)
640 x 480	3	3	3	3	3
800 x 600 noninterlaced	3	3	3	2	2
1024 x 768 interlaced	3	3	2	2	2
1024 x 768 noninterlaced	3	2	2	2	2
1280 x 1024 interlaced	2	1	1	1	1
1280 x 1024 noninterlaced	2	1	1	1	1

Quality 3 = Near perfect; screen defects are not conspicuous

Quality 2 = Good to very good; images are clear; there are small reflections around text lettering depending on the color; screen defects are sometimes conspicuous

Quality 1 = Fair to poor as distance increases; images run from slightly fuzzy to badly smeared; text runs from fuzzy but readable to completely washed out

By contrast, coaxial cables (standard for Apple and Sun applications, required for XGA applications) do much better at maintaining video quality, as shown in Table 4-3 below. (For the meaning of quality numbers **3**, **2**, and **1**, see the bottom of page 34.) As before, the distances in the table are total cable lengths measured from the CPU to the monitor. Also as before, the table assumes a single ServManager is between the CPU and monitor; if there is a submaster as well, video quality will always be lower.

Table 4-3. Video Quality vs. Distance for Coaxial Cables

Resolution \ Distance	10 ft. (3 m)	20 ft. (6.1 m)	30 ft. (9.1 m)	50 ft. (15.2 m)	75 ft. (22.9 m)	100 ft. (30.5 m)	150 ft. (45.7 m)	200 ft. (61 m)
640 x 480	3	3	3	3	3	3	2	2
800 x 600 noninterl.	3	3	3	3	3	3	2	2
1024 x 768 interlaced	3	3	3	3	3	3	2	2
1024 x 768 noninterl.	3	3	3	3	2	2	2	1
1280 x 1024 interlaced	3	2	2	2	2	1	1	1
1280 x 1024 noninterl.	3	2	2	1	1	1	1	1

CAUTION!

Some CPUs can't drive or receive keyboard and mouse signals across longer runs of coaxial cable. Consult with the manufacturers of your CPUs before installing this cable in lengths greater than 20 ft. (6.1 m).

For CPU-to-monitor distances over 200 feet (61 m), Station Extenders might be required. Call Black Box for technical support.

One last note of caution about video: The IBM 9515, 9517, and 9518 monitors that come with some PS/2 systems are not normal VGA monitors and require special cabling in order for video to be correctly sized and synchronized. Call Black Box for technical support if you want to use one of these monitors.

4.2 Keyboard-Command Summary

Table 4-4 below and on the next two pages summarizes the commands that can be sent to the ServManager. To enter any command at the shared keyboard, first press and release the left Control Key, represented by “[CTRL].” (This cues the ServManager to look for commands from the keyboard.) Then enter the command followed by any arguments you wish to specify (the port number, for example).

Letter commands are not case-sensitive; they are all shown in uppercase for clarity only.

When you enter numeric commands or arguments, use only the numbered keys at the top of your alphanumeric keyboard. Numbers entered from the numeric keypad to the right will not be recognized as valid commands.

All of these commands have a two-second timeout between characters. This means that if you begin entering a command, but you stop for more than two seconds at any time before you type the final character, the command is aborted and the ServManager returns to normal operation. This keeps the ServManager from getting stuck waiting for you to finish the command.

The [CTRL] character is always passed through to the CPU. The command characters and operands, however, are absorbed by the ServManager and are not sent to the CPU.

Table 4-4. The ServManager’s Keyboard Commands

Command	Keystroke Sequence	Description
Select Port	[CTRL] xxx (xxx = a 1- to 3-digit port number)	Connects your shared monitor, keyboard, and mouse to the specified port.
Switch to the Next Port	[CTRL] +	Switches to the next port in sequence. (You can also do this by pressing the ↑ button on the ServManager’s front-panel keypad.)
Switch to the Previous Port	[CTRL] -	Switches to the previous port in sequence. (You can also do this by pressing the ↓ button on the ServManager’s front-panel keypad.)
Scan ON	[CTRL] S	Turns Scan mode ON, causing the ServManager to start scanning sequentially from the current port through the remaining ports and then begin again at Port 1.

Command	Keystroke Sequence	Description
Scan OFF	[CTRL] X	Turns Scan mode OFF (the port being scanned at the time the command is entered is given access to the shared monitor, keyboard, and mouse). Note: Scan can also be stopped by entering a Select Port command.
Keep Settings	[CTRL] K	Enter this command after you enter any of the following eight commands (it saves new settings to nonvolatile memory):
Set Scan-Delay Time	[CTRL] Txxx [ENTER] (xxx = delay in seconds from 1 to 999)	Sets the time, in seconds, that the ServManager will pause at each port when scanning.
Set Keyboard Mode or Mouse Type	(Select port, then:) [CTRL] Mx [ENTER] (x = 1, 2, or 3)	Tells the ServManager the keyboard mode and mouse type of the CPU on the given port. Issue this command to force a port to operate in a given mode, or before any time you attach an already-booted CPU to the ServManager.
Set Name	[CTRL] [F12] (CPU must be at a prompt or be otherwise able to display text)	Tells the ServManager the names of any attached CPUs, starting with the currently selected CPU.
Set Maximum Number of Ports	[CTRL] Pxxx [ENTER] (xxx = a 1- to 3-digit number from 2 to 256)	Tells the ServManager the total number of ports to which devices are (or will be) connected. Issue this command when you're not using all of the ports on a unit with 4 or more ports, or when you cascade units.
Set Width of Submasters	[CTRL] Wxxx [ENTER] (xxx = a 1- to 3-digit number from 2 to 255)	Tells the ServManager how wide all of the attached submasters are (that is, how many CPU ports each submaster has).
Set Units	[CTRL] Uxxx [ENTER] (xxx = a 1- to 3-digit number from 0 to 255)	Tells the ServManager how many submasters are attached to it.
Set Screen Saver's Delay Time	[CTRL] Vxxx [ENTER] (xxx = delay in seconds)	Sets the time of inactivity, in seconds, after which the ServManager will blank the shared monitor's screen. (The monitor is reactivated when the PS/2 mouse is moved or any key on the shared keyboard is pressed.)

Table 4-4. The ServManager's Keyboard Commands (cont'd.)

Command	Keystroke Sequence	Description
Set Keyboard Typematic	[CTRL] Axxx [ENTER] (xxx = a decimal value from 0 to 127)	Sets the keyboard typematic (automatic key-repeat) function of the currently selected CPU. This command works only with PC-type CPUs that have standard 101-key keyboards and CMOS that allows users to program the typematic function.
Reset	[CTRL] R	Resets and enables the keyboard and mouse; also refreshes the monitor. Issue this command to correct your keyboard or mouse if one of them malfunctions or gets stuck.
Send Null Byte	[CTRL] N	Causes the ServManager to send a null byte to the CPU's PS/2 mouse port. Issue this command to correct the current CPU if it gets "out of sync" with the PS/2 mouse (see Section 4.3.13).
Identify ROM	[CTRL] I	Causes the ServManager to report the version of ROM it is using. Issue this command if you are asked to do so by a technical-support person.

4.3 The Commands in Detail

4.3.1 SELECTING A PORT FROM THE SHARED KEYBOARD

To select a port from your keyboard, press and release your keyboard's left Control Key ([CTRL]), then type in the port number:

If "Maximum Ports" is set to 1 to 9: The ServManager will immediately switch to the desired port when you press the one-digit number's numeral key.

If "Maximum Ports" is set to 10 to 99: The ServManager will immediately switch to the desired port when you press the two-digit number's second numeral key. For single-digit ports, you can enter the number by including a leading zero ("01" for port 1) or by pressing [ENTER] after you press the single numeral key. If you press the key of only one digit, and do not follow it with [ENTER], the ServManager will wait two seconds for you to press [ENTER] or another numeral key; then, if no key is pressed, it will switch immediately to the single-digit port.

If “Maximum Ports” is set to 100 to 256: The ServManager will immediately switch to the desired port when you press the three-digit number’s third numeral key. For single- and double-digit ports, you can enter the number by including one or two leading zeros (“001” for port 1 or “027” for port 27) or by pressing [ENTER] after you press the single or second numeral key. As noted above, the ServManager will wait two seconds for you to enter another digit, then will switch to the partially entered port number.

4.3.2 SWITCHING TO THE NEXT OR PREVIOUS PORT

From the keyboard you can go forward or backward through the ServManager’s ports by selecting either the next or the previous port respectively. To switch to the next port, press and release the left Control Key ([CTRL]), then press the plus key (the key at the top of the keyboard marked with [=] and [+]). To switch to the previous port, press and release [CTRL], then press the minus key (the key at the top of the keyboard marked with [-] and [_]). The command is not case-sensitive. Do *not* use the [+] and [-] keys on the keyboard’s numeric pad; the ServManager doesn’t recognize these.

You can also select the next or previous port manually from the ServManager’s front panel by pushing the button on the keypad labeled ↑ or ↓ respectively. Each time you press the button, the next or previous port in sequence is selected.

4.3.3 SCAN MODE

To enable scanning (switching from CPU to CPU in a continuous rotation) from the keyboard, press and release the left Control Key ([CTRL]), then press [S]. The ServManager will begin scanning sequentially from its currently selected port through the higher-numbered ports, then begin again at CPU Port 1. As it scans, it delays 1 to 999 seconds at each port. (This “Scan-Delay Time” is user-selectable; see **Section 4.3.5.**) To stop scanning, press and release [CTRL], then press [X]. You can also disable scanning by entering a Select Port command. ServManager letter commands are not case-sensitive: You can enter upper- or lower-case letters.

To enable scanning from the front panel of a single or master ServManager, use the menu to turn “Scan mode” ON (see **Section 4.4.2.**)

4.3.4 KEEP SETTINGS

The Keep Settings command saves the current state of the ServManager's configuration settings to nonvolatile memory (NVRAM), where they become the new default (loaded at power-up) settings. To enter the command, press and release the left Control Key, then type [K]. The eight configuration settings are described in the next eight sections.

4.3.5 SET SCAN-DELAY TIME

Issue the Set Scan-Delay Time command to set the time, in seconds, that the ServManager will pause at each of the CPU ports when it's scanning them. The factory-default setting is 5 seconds. To set a different delay time, press and release the left Control Key, type [T] followed by the new delay time in seconds (1 to 999), and press [ENTER]. Enter the Keep Settings command after you enter this.

If you issue this command with an argument of zero, the ServManager will set the scan-delay time to the default value most recently saved in NVRAM.

4.3.6 SET KEYBOARD MODE OR MOUSE TYPE

Unless all of your CPUs are IBM PC type and are set for Mode 2 keyboard input and PS/2 mouse input, you'll have to specify the type of keyboard and mouse interface required by each of your CPUs. This is fairly straightforward for Apple and Sun CPUs, because their keyboard and mouse interfaces are consistent across the board and do not vary from model to model. PCs, on the other hand, can have any of three different keyboard modes and several types of mouse interfaces. Each CPU attached to the ServManager can be configured for either Apple, Sun, or any mix of PC-type keyboard modes and mouse interfaces. The ServManager does not support using a keyboard from one platform with a mouse from a different platform (an Apple keyboard with a PC or Sun mouse, for example).

The following subsections explain keyboard modes and mouse interfaces in more detail and describe the command procedure and possible settings.

4.3.6.A Keyboard Modes

Keyboard “modes” are electrical signaling protocols that determine how a powered CPU and keyboard interact. A CPU and keyboard must use the same mode in order to work with each other. Of the three standard keyboard modes currently in use by IBM type computers, mode number 2 is the one used by the vast majority of CPUs. It is also the default state of all 101-key and PS/2 keyboards. Mode 1 is used primarily by certain PS/2 CPUs. Mode 3 is used by RS/6000® CPUs, some other UNIX® based computers, and certain specialized servers.

The ServManager supports all three of these modes: As it receives signals from the keyboard, it sends them to the currently selected CPU by emulating a keyboard of the appropriate mode for that CPU; as it receives signals for the keyboard from the currently selected or scanned CPU, it sends them to the keyboard by emulating a CPU of the appropriate mode.

Most CPUs that use keyboard mode 1 or 3 send a “mode command” to the keyboard at power-up, to put the keyboard in the proper mode. ServManagers and submaster ServSwitches can use these commands to automatically detect each such CPU’s keyboard mode when you turn on the CPU *after* it has been cabled to the ServManager. However, ServManagers don’t automatically save this value; unless you send them a Keep Settings command, they will forget the modes they have detected when they are turned OFF, then default to each port’s most recently saved setting when they’re turned ON again.

The ServManager can’t detect the CPU’s keyboard mode if your CPU doesn’t send “mode commands” (most CPUs that use mode 2 fall into this category) or if the CPU is already ON when you connect it to the ServManager (it shouldn’t be). In these situations, the ServManager tries to use the keyboard-mode setting stored in its nonvolatile memory for that port. The factory default is mode 2 for all ports. Send the Set Keyboard Mode command to change the keyboard mode for a port if:

- the CPU on that port uses mode 1 or 3,
- it uses mode 2, but the default setting of the port you want to connect it to has been changed, or
- you don’t know which mode the CPU uses or the port is set for, but the keyboard’s behavior makes you suspect that the port’s setting is wrong.

4.3.6.B Mouse Interfaces

IBM PC type computers have several types of mouse interfaces as well. The ServManager supports four: PS/2, Microsoft serial, PC Mouse (Mouse Systems), and 8-bit serial.

The PS/2 mouse interface uses a 6-pin mini-DIN connector and is similar to the PS/2 keyboard interface. The advantage of the PS/2 mouse is that it is built onto the motherboard and doesn't occupy any of the CPU's serial ports.

The serial mouse interfaces all use the EIA/TIA RS-232 serial standard, implemented on either a DB25 or a DE9 ("DB9") connector, and all of them communicate with the PC at a data rate of 1200 bps. Microsoft mice use a 3-byte/7-bit protocol; unlike the other three types of mice you can choose from, they do not support a third button. 8-bit serial mice use a 3-byte/8-bit protocol. PC Mouse (also known as Mouse Systems) serial mice use a 5-byte/8-bit protocol; many lower-cost mice have a switch that you can set for either Microsoft compatible operation or PC Mouse compatible operation.

4.3.6.C Command Procedure

Selecting the Apple or Sun keyboard/mouse combo only requires a single command; selecting an IBM type keyboard and mouse requires two commands—one for the keyboard and one for the mouse. When you issue a command to change from an Apple or Sun keyboard to an IBM type keyboard, the ServManager will automatically set the mouse interface to PS/2; until you make this keyboard change, any attempt to change from an Apple or Sun mouse to an IBM type mouse will be ignored.

To set the keyboard mode or mouse interface of the currently selected port on a single or master unit, take these steps:

- Press and release the left Control Key, then type [M];
- Referring to Table 4-5 on the next page, press the numeral key corresponding to the code of the keyboard or mouse type you want; and
- Press [ENTER].

For example, to choose the Sun keyboard and mouse, you would type [CTRL] [M] [4] [ENTER]. To choose a Mode 2 keyboard with a Microsoft serial mouse, you would type [CTRL] [M] [2] [ENTER] followed by [CTRL] [M] [7] [ENTER].

After you enter this command, enter the Keep Settings command to save the mode setting in NVRAM, so that the new setting becomes the default value (preserved during power-down and reloaded at power-up).

Before you can set the keyboard mode or mouse interface of the currently selected port on a submaster unit, you have to isolate it from the rest of the system. (Note that this step might be unnecessary if all of your CPUs are IBM type; the submaster should be able to automatically detect the keyboard mode when you turn ON CPUs that use mode 1 or 3, and mode 2—used by most IBM type PCs—is the default keyboard mode of the ServManager and the ServSwitches.) First disconnect the submaster from the ServManager, plug a keyboard into its MONITOR/KEYBOARD/ MOUSE port (this will require an MKM Adapter Cable), make sure the SCAN button is in the “out” position, and select the port as if the submaster were a single unit. Then issue the Set Keyboard Mode and Keep Settings commands as described in the previous paragraphs. Unplug the keyboard and reconnect the submaster to the master ServManager. The port’s keyboard mode should now be properly configured.

If most or all of the CPUs you’ll be connecting to your ServManager system use a keyboard mode other than 2 and a mouse type other than PS/2, you might want to change the defaults of their ServManager/submaster ports at installation time. This is because when power outages occur, the ServManager/submaster ports will return to their default keyboard mode when the power comes back on.

Table 4-5. Keyboard-Mode and Mouse-Interface Codes

Code	Selects
1	IBM PC keyboard mode 1
2	IBM PC keyboard mode 2
3	IBM PC keyboard mode 3
4	Apple keyboard and mouse
5	Sun keyboard and mouse
6	PS/2 mouse
7	Microsoft serial mouse
8	Other 8-bit serial mouse
9	PC Mouse (Mouse Systems) serial mouse

4.3.7 SET NAME

With this command, you can conveniently enter the CPU names that are displayed on the ServManager's front panel. You can always enter or change names using the front-panel keypad (see **Section 4.4**), but this way is much easier.

For the Set Name command to work, the currently selected CPU needs to be at some sort of operating-system prompt, or in some application such as a word processor or text editor which displays typed characters immediately:

- For an IBM type CPU, this could be the DOS or OS/2[®] command prompt, the DOS EDIT screen, the Windows Notepad, or any word processor or text editor.
- For a Macintosh CPU, this could be TeachText[®], Simple Text[®], or any word processor or text editor.
- For a Sun CPU, this could be the command tool prompt, boot prompt, or any word processor or text editor.

To set the name of the currently selected CPU, press and release the left Control key, then hit the [F12] key. A message that looks like this should appear on your computer screen:

```
Name    1 = CPU 1      Change Y/N/Esc?
```

The text displayed shows you the existing or default name of the currently selected CPU. (This example assumes that CPU 1 is the currently selected CPU and that its default name has not been changed from "CPU 1".) To change the name, enter "Y"; the name should be erased, leaving:

```
Name    1 =
```

You can type in the new name and confirm it by pressing [Enter], or you can hit [Esc] to abort the name change. You can use the [Backspace] key to correct any errors as you type. You can use the [Shift] key to change the case of letters or to enter shifted characters. Any character in the normal ASCII character set is available.

Once you hit [Enter], the ServManager will backspace over what you have typed and display the name it received, like this:

```
Name    1 = Mail server #1  Change Y/N/Esc?
```

The name is automatically stored in flash configuration memory. If the name is wrong, hit [Y] to re-enter it. If it looks OK, you can hit the [Esc] key to exit the name command or hit [N] to see the name of the next-higher-numbered port. In this manner you can view and change names on any CPU that you wish to. When you change the name of the port that is currently selected, the ServManager's front-panel display will be updated with the new name as soon as you hit the [Enter] key.

You can hit [Esc] at any time to quit the Set Name command. There is no automatic exit from this command, so be sure to hit [Esc] when you've finished configuring the names.

4.3.8 SET MAXIMUM PORTS

Use this command to tell a ServManager the total number of ports in its system (on that ServManager and all attached submasters) to which devices are or will be connected. This allows the scan function to cycle correctly with CPUs connected to more or fewer ports than the factory default for this option, which is the total number of ports on the ServManager ("4" for a 4-port unit, "8" for an 8-port, etc.). Although this command is used primarily for cascading, it can also be used to enable only some of the ports of a single ServManager.

To issue the Set Maximum Ports command to a single or master ServManager (*not* to any submasters), press and release the left Control Key, type [P] followed by the total number of ports accessible to that ServManager (from 1 to 3 digits), and press [ENTER]. Issue the Keep Settings command after you issue this command.

Maximum Ports can be set to any value from 2 to 256. We don't recommend attaching submasters with different numbers of ports to the same ServManager; if you do, you might have to count ports that do not actually exist (see **Section 3.3.2**). Also note that if you are sharing Matrix ServSwitch submasters between two ServManager masters in your system, the Maximum Ports value might have to be set differently for each ServManager.

4.3.9 SET WIDTH OF SUBMASTERS

Use this command to tell a ServManager how “wide” your submasters are (that is, how many ports each of your submasters has). If your submasters are all 8-port models, set the Width to 8; if they are all 12-port models, set the Width to 12; and so on.

Because initial configuration and reconfiguration would be complex and time-consuming otherwise, Width is an all-or-nothing proposition for the ServManager: One Width value is used for every port. Because this is true, we strongly recommend that all submasters you attach to a ServManager be the same size. If you must attach different-sized submasters, please recognize that you will probably either be unable to use some ports or will have to account for nonexistent ports when you calculate port numbers and when you scan. See **Section 3.3.2**.

Figure 4-1 on the next page is an illustration of why ServManagers need to know this value. Without a number for Width—even assuming that Units is set correctly to 4—if you were to select CPU 7 on either ServManager, they would not know whether CPU 7 was attached to the submaster on port 4, the one on port 2, or (in the non-included case of 8-, 12-, or 16-port submasters) on port 1. With Width, the ServManager knows to switch to port 4 and send the “switch to port 1” command if Width is 2, or to switch to port 2 and send the “switch to port 3” command if Width is 4.

The default setting for Width is 16. To issue the Set Width of Submasters command for a ServManager (which you may do at any time), press and release the left Control Key, type [W] followed by the number of ports on the attached submasters (from 1 to 3 digits), and press [ENTER]. Enter the Keep Settings command after you enter this command. Width can be set to any value from 2 to 255, but Width values higher than 16 (allowed in order to support future expansion capabilities) might cause the ServManager to behave unpredictably.

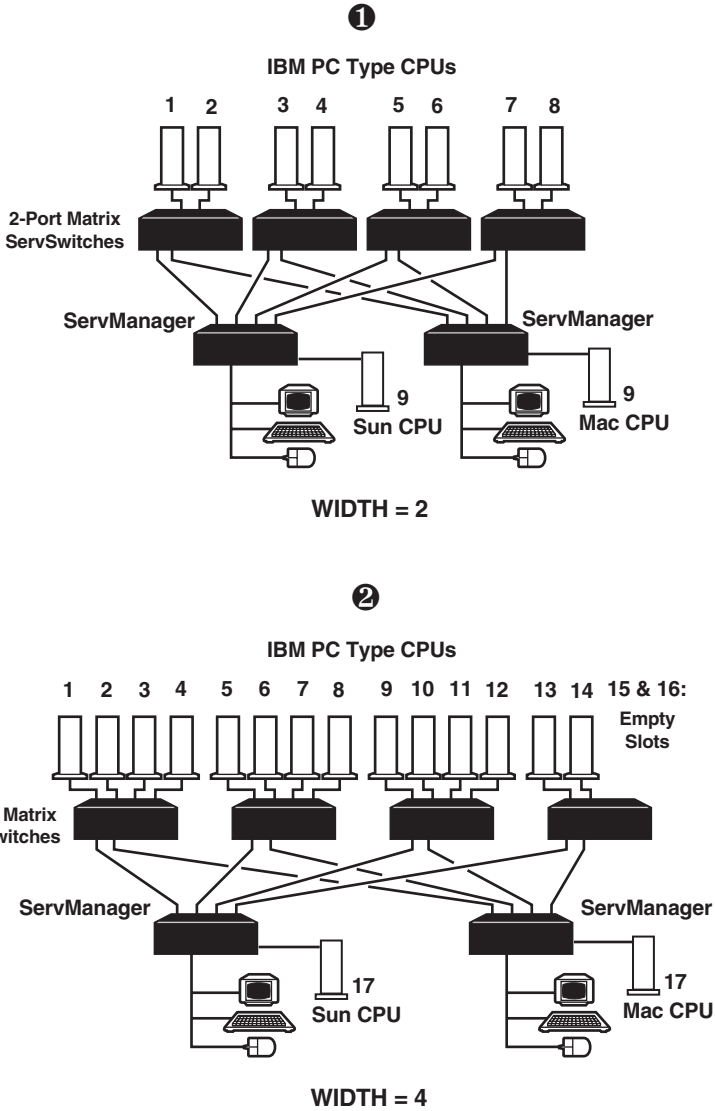

Fig. 4-1. Alternative configurations which the ServManager uses Width to help resolve.

4.3.10 SET UNITS

Use this command to tell a ServManager how many submasters (as opposed to CPUs) are directly attached to it. It doesn't matter what kind of ServSwitch device the submaster is. For example, if you were to take an 8-port ServManager and directly attach another ServManager, three Matrix ServSwitches, an original ServSwitch, and two CPUs, the ServManager would have five submasters on it, so you would set Units to 5.

CAUTION!

We strongly recommend that you do not attach submasters of different types to a master ServManager. If you must do so, make sure that all of the CPUs attached to any submaster Matrix ServSwitches or original ServSwitches are IBM type CPUs, and that all of the CPUs attached to each such submaster use the same type of keyboard and mouse input.

ServManagers use the Units value to find CPU ports. If you select a CPU that is directly attached to the ServManager, the ServManager can simply switch to that CPU port. However, if you select a CPU attached to a submaster, the ServManager has to switch to the submaster's port and issue switching commands to the submaster. The Units setting is the only way it knows where, for example, CPU 18 is, and how to go about accessing that port.

Figure 4-2 on the next page shows a typical pair of alternatives that the ServManager can't resolve properly unless Units is set correctly. The ServManager in the diagram can't tell merely from its hardware connections how many submasters it is attached to. Without a number for Units—even assuming that Width is set correctly to 4—if you were to select CPU 7 on that ServManager, it would not know whether CPU 7 was attached to a submaster on port 2 or directly attached on port 4. With Units, the ServManager knows to switch to port 4 if Units is 1 or to switch to port 2 and send the “switch to port 3” command if Units is 2.

The default value for Units is 0 (zero). To set Units for a ServManager (which you may do at any time), press and release the left Control Key, type [U] followed by the number of submasters (from 1 to 3 digits), and press [ENTER]. Enter the Keep Settings command after you enter this command. Units can be set to any value from 0 to 255, but Units values higher than the number of ports on your ServManager (allowed in order to support future expansion capabilities) might cause the ServManager to behave unpredictably.

Please note that if you are sharing Matrix ServSwitch submasters between two ServManager masters in your system, and especially if you have submasters of other types attached to one or both masters, the Units value might have to be set differently for each master.

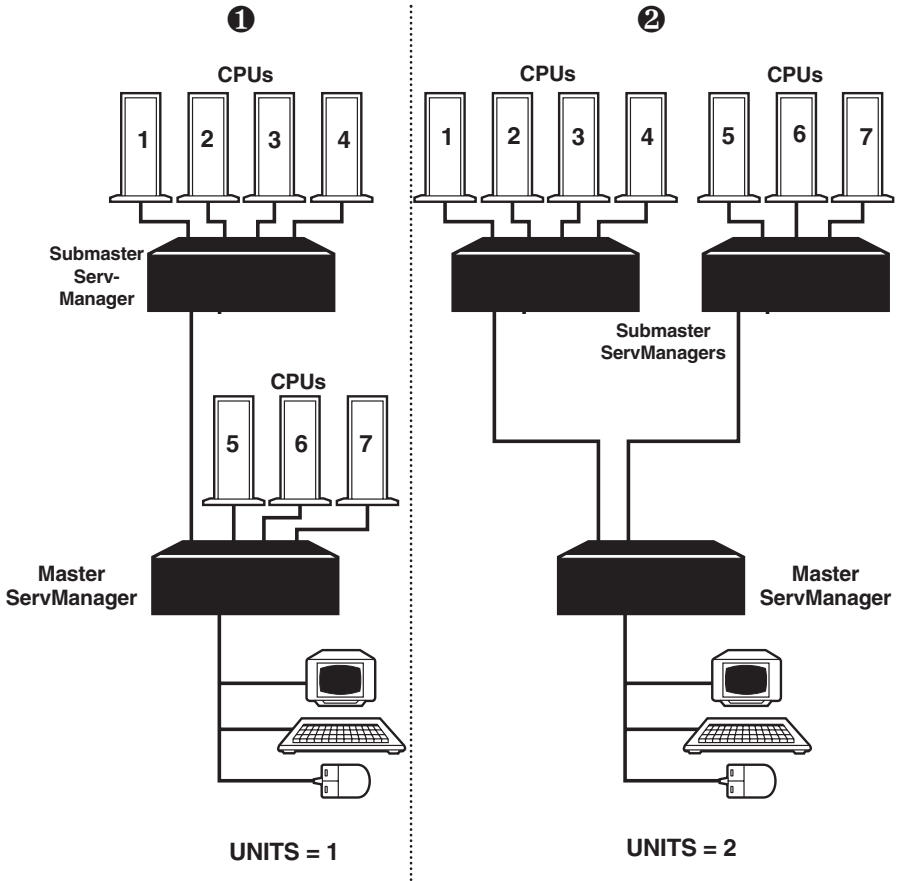

Fig. 4-2. Alternative configurations which the ServManager needs Units to resolve.

If you are having difficulty switching between ports or scanning, and one or more of your CPUs are receiving spurious data, check the Units setting of the ServManager you are using; you are probably seeing misdirected switching commands that the ServManager thinks it is sending to submasters.

4.3.11 SET SCREEN-SAVER INTERVAL

This feature reduces the wear on your shared screen and provides security for your system by blanking the screen when there has been no keyboard activity for a specified length of time. To set the screen-saver interval, press and release the left Control Key, type [V] followed by the interval time in seconds (1 to 999, or 0 to disable the screen saver), and press [ENTER]. Enter the Keep Settings command after you enter this command.

While the screen is blanked, the second line of the ServManager's front-panel display will read:

```
Status> Video off
```

To reactivate the screen when it's been blanked, press any key on the keyboard or move the mouse. The default setting of this option is 0 (screen saver disabled).

NOTE

When the ServManager is in the Screen-Saver state, all of its SELECT LEDs will be OFF.

4.3.12 SET KEYBOARD TYPEMATIC

Most IBM type keyboards have an internal seven-bit “typematic” setting, which governs the way the keyboard responds when you hold a key down to force it to repeat. (This command does not apply to Apple or Sun keyboards, because the ServManager does not support the typematic function for them at this time.) The five “low” bits of this setting represent the *rate* at which the key repeats; the two “high” bits represent the *delay* after you begin holding down the key before it begins to repeat.

Sometimes a keyboard’s typematic setting isn’t suitable for a given operator or for a given application. To change the shared keyboard’s typematic setting, issue the Set Keyboard Typematic command: Press and release the left Control Key, type [A] followed by the desired “typematic value,” and press [ENTER]. The “typematic value” is the decimal equivalent of the binary seven-bit typematic setting: While the typematic setting = delay bits + rate bits, the typematic value = *decimal* delay value + *decimal* rate value (see Table 4-6 below and Table 4-7 on the next page). For example, to set the shared keyboard to register a key 16 times per second after the key has been held down for half a second (typematic value = 7 + 32 = 39), type [CTRL] [A] [3] [9] [ENTER].

Table 4-6. Typematic Delay

Decimal Value	Binary Bit Values	Delay Before Key Repeats
0	00[xxxxx]	1/4 second (250 ms)
32	01[xxxxx]	1/2 second (500 ms)
64	10[xxxxx]	3/4 second (750 ms)
96	11[xxxxx]	1 second (1000 ms)

Table 4-7. Typematic Rate

Decimal Value	Binary Bit Values	Repeat Rate in Keys per Second
0	[xx]00000	30
1	[xx]00001	26.7
2	[xx]00010	24
3	[xx]00011	21.8
4	[xx]00100	20
5	[xx]00101	18.5
6	[xx]00110	17.1
7	[xx]00111	16
8	[xx]01000	15
9	[xx]01001	13.3
10	[xx]01010	12
11	[xx]01011	10.9
12	[xx]01100	10
13	[xx]01101	9.2
14	[xx]01110	8.6
15	[xx]01111	8
16	[xx]10000	7.5
17	[xx]10001	6.7
18	[xx]10010	6
19	[xx]10011	5.5
20	[xx]10100	5
21	[xx]10101	4.6
22	[xx]10110	4.3
23	[xx]10111	4
24	[xx]11000	3.7
25	[xx]11001	3.3
26	[xx]11010	3
27	[xx]11011	2.7
28	[xx]11100	2.5
29	[xx]11101	2.3
30	[xx]11110	2.1
31	[xx]11111	2

4.3.13 RESET

This command, along with the two commands described in the next two sections, comes in handy when certain problems arise. It will reset or refresh your shared equipment. Issue it if (a) your shared keyboard gets stuck or begins behaving oddly, (b) you need to send mouse data to a CPU which hasn't enabled the mouse (this can happen if you boot up the CPU while the ServManager is off or disconnected), (c) your video display has not been updated to show current conditions, or (d) while using a PS/2 type mouse, you unplug it, then plug it back in. To issue the Reset command, press and release the left Control Key, then type [R].

If you're using a PS/2 type mouse, don't issue this command to a CPU that doesn't have a mouse driver loaded. Many CPUs will crash if you send them unexpected mouse data.

4.3.14 SEND NULL BYTE

PS/2 type mice send control data to CPUs in three-byte increments. Sometimes, because of electronic transients, unusual power-up effects, or plugging and unplugging of cables from live equipment, the currently selected CPU in a ServManager system can lose one or two bytes of this control information and get "out of sync" with the shared mouse. In this situation, the mouse might seem to refuse to move the pointer or cursor, open windows for no reason, or exhibit other strange behavior. To get the CPU back in sync, send this command to tell the ServManager to send a "null byte" to the CPU's PS/2 mouse port (this has no other effect than getting the CPU "caught up"). To issue the Send Null Byte command, press and release the left Control Key, then type [N].

If the mouse still isn't right after you issue this command, the CPU must have been two bytes out of sync. Issuing the command again should do the trick.

The CPU will be thrown out of sync if it uses a PS/2 mouse and it's in sync when you issue this command. Issue this command two more times to get it back in sync again. This command has no effect on serial mice, or on CPUs that are not attached to your ServManager system through a PS/2 mouse port.

If you have version 9.01 or higher of the Microsoft mouse driver, the CPU should never get out of sync. Contact Microsoft if you would like to upgrade your Microsoft mouse driver.

4.3.15 IDENTIFY ROM

Unfortunately, as with all complex equipment, problems might arise with your ServManager that require the assistance of technical-support personnel. One of the things technicians might want to know when they attempt to diagnose and correct your problem is the revision level of your ServManager's ROM. This command causes the ServManager to send the three-character "x.x" ROM level to the currently selected CPU; these characters will be echoed back to the shared monitor if you are at some type of prompt. To issue the Identify ROM command, press and release the left Control Key, then type [I].

4.4 Using the Front-Panel Display and Keypad

Through the front panel you can do almost everything that can be done from the keyboard. The front panel is convenient for configuring and viewing all configuration items.

4.4.1 NORMAL OPERATION

4.4.1.A The Power-Up Display

Upon power-up, the display immediately shows the revision of the ServManager firmware. As the ServManager performs its power-up diagnostics, it displays a diamond for each step it successfully completes, then shows "OK" once all tests have completed successfully. If there are failures it will show an error message on display line 2. If you receive an error message, see **Appendix C** for an explanation of what it means.

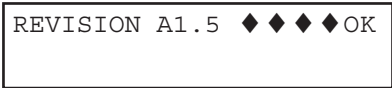

```
REVISION A1.5 ◆◆◆OK
```

4.4.1.B Normal Display

Once the power-up diagnostics have been completed successfully, the display for a single or master ServManager shows the name and number of CPU 1 and its power status. The status line may show “normal” or “no CPU power.” In this example, the default name “CPU 1” is shown on the left of line 1 and the CPU number is shown on the right.

```
CPU 1          1
Status> normal
```

In a cascaded system, this will also be displayed on a submaster ServManager attached to the master’s CPU port 1. All other submaster ServManagers will be notified by the master that they are not selected, and will display this:

```
Status> not selected
```

In a cascaded system, if you select a CPU port on the master to which a submaster is attached, and the submaster (a) has been turned OFF or physically disconnected since system power-up, or (b) is an older ServSwitch that doesn’t support power-status reporting, the status line might not report an accurate value; it might say “normal” even though power is OFF, or “no CPU power” even though power is ON.

4.4.1.C Switching CPUs from the Front Panel

Standard Procedure

To switch CPUs from the front panel, use the up- and down-arrows to scroll through the CPUs. This will switch to the CPUs in numeric sequence. You can also use the numeric keypad to enter the port number directly. Use the rules described in **Section 4.3.1** to determine how many digits to enter. If you have maximum ports set more than 9, as you enter the port number the display will show the number being entered on the top right of the display. You can use either the left- or right-arrow key as a backspace. As when entering from the keyboard, you have two seconds between keystrokes to enter a number.

Using Review Mode to Switch CPUs

You can use the left- and right-arrow keys to cycle through the CPUs by name and number before switching to one. Hitting the right-arrow key will show you the name of the next sequential CPU on the bottom line of the display. Hitting the left-arrow will show you the name of the previous CPU. Hitting ENTER will switch to the port you have scrolled to. Hitting any other key returns the display to normal mode.

4.4.1.D Display Blanking

After two hours of no keypad activity, the front-panel display is turned off to protect the display phosphors. Hit any key to restore the display.

4.4.1.E Keypad Repeat

The arrow keys on the front-panel keypad have a repeat function. If you hold down the key it will repeat, and after two repeats it will speed up. This is useful when you want to scroll through a large number of items, such as using review mode with many CPUs or configuring the CPU names from the front panel.

4.4.2 THE CONFIGURATION MENU

Hitting the MENU key causes you to enter the configuration mode.

4.4.2.A Scan Mode

The first item on the configuration menu to be displayed is scan mode.

```
Scan mode>  Off
Enter•select ↑↓•item
```

The bottom line is common to all menu items. Using the up- and down-arrows on the keypad will scroll through the possible items that can be accessed. Using the ENTER key will allow you to modify the item.

If you hit ENTER at scan mode, you will see the following display:

```
Scan mode>  Off
Choose↑↓ Off
```

You can use the up- and down-arrows to scroll between off and on. Hit ENTER to select your choice. If you turn scan mode on, it will not start until you leave the configuration menu.

4.4.2.B Scan Time

The next item on the menu is the scan time. It looks like this:

```
Scan time>  5
Enter•select ↑↓•item
```

Hitting ENTER will bring up the following display, where you may enter a new value between 1 and 999.

```
Scan time>  5
New value(1-999) ■
```

The ■ is a flashing cursor which directs you to enter a new value using the numeric keys followed by ENTER. The values in parentheses “(1-999)” tell you the range of values that you may enter. You can hit the MENU key at any time to abort the entry. If a new value is entered, then the value is displayed on the top line of the previous display, and you return to the main configuration menu, where you may continue to access menu items.

4.4.2.C Power-On Scan

The next item on the menu is the power-on scan. This setting determines if the ServManager will go into scan mode at the previously specified time interval when it is first powered on. Use the up- and down-arrows to choose between yes or no.

```
Power on scan> No
Choose↑↓ No
```

4.4.2.D Keyboard

The next item after power-on scan is:

```
Keyboard> PC
Enter•select ↑↓•item
```

This submenu allows you to enter the type of shared keyboard being used. If you hit ENTER at this point you will see the following display:

```
Keyboard> PC
Choose↑↓ PC
```

This item is directing you to use the up- and down-arrow keys to scroll through a list of choices. In this case you can choose PC, Mac, or Sun. As with the maximum ports, if a new value is entered, then the value is displayed on the top line of the previous display and you may continue to access menu items. Hitting ENTER also has the effect of resetting the keyboard.

4.4.2.E Mouse

The next submenu concerns changing the mouse interface. (If you have chosen Mac or Sun in the previous step, this item will not appear.)

```
Mouse>PS/2
Enter•select ↑↓•item
```

This submenu works similarly to the keyboard submenu described above. Your choices for mouse are PS/2, Microsoft serial, other 8-bit, and PC Mouse (Mouse Systems). Please refer to **Section 4.3.6** for more information about these choices. Hit ENTER to select your choice (this also has the effect of resetting the mouse).

4.4.2.F CPU Keyboard/Mouse

The next menu item allows you to change the keyboard and mouse for each CPU. It looks like this:

```
CPU keyboard/mouse
Enter•select ↑↓•item
```

Hitting ENTER at this item will bring up the following display:

```
Choose↑↓←→ CPU> 1
KB>PC2 MS>PS/2
```

The way this submenu works is different from the previous two. You can also use the left- and right-arrow keys, which allows you to move between the CPU, KB (keyboard) and MS (mouse) fields. Once you are in a field you can use the up- and down-arrow keys to scroll through the possible selections.

The choices for CPU are from 1 to the maximum number of ports. The choices for KB are PC1, PC2, PC3, Mac, and Sun. PC1, PC2, and PC3 refer to IBM type keyboard modes 1, 2, and 3. If you enter Mac or Sun for the keyboard, you cannot change the mouse setting. The choices for mouse are PS/2, Microsoft serial, other 8-bit serial, and serial PC Mouse. Please refer to

Section 4.3.6 for more information about the choices for keyboard and mouse. Once the keyboard and mouse are selected, you can hit ENTER at either field and that will save the setting. The cursor then goes back to the CPU field. (If you use the left- or right- arrow key to get back to the CPU field, then use the up- or down-arrow to change to a different CPU, this also saves the new setting.) Hitting the MENU key will bring you back to the main configuration menu.

4.4.2.G CPU Names

The next item on the menu allows you to change the name of a CPU displayed on the front panel. It looks like this:

```
CPU names
Enter•select ↑↓•item
```

Hitting ENTER at this item will bring up the following display:

```
Choose↑↓←→ CPU> 1
NameCPU 1
```

The method of navigating through this submenu is similar to that of the CPU keyboard and mouse submenu described above. When you first enter this menu, the cursor is pointing at the name of the currently selected CPU. Use the up- and down-arrows to cycle through the CPUs. To change the name of a CPU, use the left- and right-arrows to go to the character in the CPU name that you want to change. The cursor changes from a flashing block to an underscore. Use the up- and down-arrows to cycle through the ASCII characters. Hit ENTER while in the name field (while the cursor appears as an underscore) to save the name. The cursor then goes back to the CPU field. Hitting the MENU key will bring you back to the main configuration menu.

4.4.2.H Maximum Ports

The next item to be displayed is the maximum number of ports in the system.

```
Maximum ports> 16
Enter•select ↑↓•item
```

Hitting ENTER at this item will bring up the following display:

```
Maximum ports> 16
New value (2-256) ■
```

Enter the new value of the maximum ports followed by ENTER. This menu entry works the same way as all other menu items that require a numeric value (see **Section 4.4.2.B**).

4.4.2.I Expansion Width (Width of Submasters)

The next item on the menu is the expansion width. The Width setting determines how many CPU ports are on all attached submasters. Refer to **Section 4.3.9** for more information on Width. This menu entry works the same way as all other menu items that require a numeric value (see **Section 4.4.2.B**).

```
Expansion width> 16
New value (1-16) ■
```

4.4.2.J Expansion Units (Number of Submaster Units)

The next item on the menu is the expansion units. The Units setting is the number of submasters attached to the master ServManager. Refer to **Section 4.3.10** for more information on Units. This menu entry works the same way as all other menu items that require a numeric value (see **Section 4.4.2.B**).

```
Expansion units> 0
New value (1-16)  ■
```

4.4.2.K Video-Blank Time (Screen-Saver Interval)

The next item on the menu is the video-blank time. This setting determines whether ServManager will blank the monitor screen after a period of no keyboard or mouse activity, and, if so, how long the no-activity period has to be in seconds. This menu entry works the same way as all other menu items that require a numeric value (see **Section 4.4.2.B**).

```
Video blank time> 0
New value (1-999)  ■
```

4.4.2.L Keyboard Typematic Rate (PC Only) or Sun Keyboard Language (Sun Only)

What appears as the next menu item depends on which type of shared keyboard you've told the ServManager it is attached to (see **Section 4.4.2.D**):

If you entered "Mac," the menu skips to "Save configuration" (see **Section 4.4.2.N** on page 64).

If you entered "PC," you are prompted to set the keyboard's typematic rate. This setting determines how fast a keyboard key repeats when it is held down. This menu entry works the same way as all other menu items that require a numeric value (see **Section 4.4.2.B**). After you set this, you are prompted to set the keyboard's typematic delay (see **Section 4.4.2.M**).

```
KB rate keys/sec> 20
New value (2-30)  ■
```

If you entered “Sun,” you might be prompted to select the Sun keyboard type and language. (A future firmware upgrade will give the ServManager the ability to autodetect this; once your unit has this firmware, the menu will skip to “Save configuration” [see **Section 4.4.2.N** on the next page].) When Sun CPUs boot up, they query the keyboard for its type and language to determine which drivers and character sets to use; the ServManager responds to attached Sun CPUs with this value. The default value “33” corresponds to a Sun Type 4 or Type 5 keyboard and the standard U.S. keyboard language. Other values less than 127 also represent Type 4/Type 5 keyboards but correspond to different keyboard languages:

33 US (default)	39 Netherlands/Dutch	45 Swiss-German
34 US/UNIX	40 Norwegian	46 United Kingdom
35 French	41 Portuguese	47 Korean
36 Danish	42 Spanish	48 Taiwan
37 German	43 Swedish/Finnish	49 Japan
38 Italian	44 Swiss-French	50 French-Canadian

If your keyboard language isn’t shown here, consult your Sun manual.

If your CPUs expect an older Sun Type 3 keyboard, enter any value from 128 to 255 (Type 3 keyboards use only the standard US keyboard language).

This menu entry works the same way as all other menu items that require a numeric value (see **Section 4.4.2.B**).

After entering a new value here, reboot the Sun CPUs attached to the ServManager system to make them adjust to the new setting. Please note that this value will affect *all* of the Sun CPUs attached to this ServManager’s system.

```
Sun kb language> 33
New value (0-255)  ■
```

4.4.2.M Keyboard Typematic Delay (PC Only)

If and only if the shared keyboard has been identified as a PC type (see **Section 4.4.2.D**), the next item on the menu is the keyboard's typematic delay. This setting determines how long after pressing a key the key will start to repeat. This submenu works the same way as all others in which you scroll among possible choices. The available choices are slow (1 second), medium (750 ms), fast (500 ms), and fastest (250 ms).

```
KB delay> Fast
Enter•select ↑↓•item
```

4.4.2.N Leaving the Configuration Menu

To leave the configuration menu, hit the MENU key. If you have not changed any settings, you are returned to the normal display mode that shows the currently selected CPU and status. If you have changed a setting other than the scan mode, you will see the following display:

```
Save configuration
Enter choice↑↓ Yes
```

Hit ENTER to save the new settings in flash configuration memory. If you don't want to save the new settings permanently, use the up- and down-arrow keys to change to "No" and hit ENTER: The new settings will still be active, but will be lost if the unit is powered OFF.

4.5 Using the RS-232 Port

4.5.1 CONNECTING EQUIPMENT TO THE PORT

For your convenience, a computer or terminal with an RS-232 serial port can be connected to the RS-232 serial port (RJ-12 connector) on the ServManager's rear panel. (See **Appendix D** for a pinout of this connector.) This allows you to send switching commands from a non-local keyboard rather than from the shared keyboard, and is also necessary in order to download future firmware upgrades into the ServManager. You'll need a 6-wire straight-through-pinned twisted-pair serial cable with RJ-12 ("6-pin RJ-

11”) connectors plus the appropriate adapter: For IBM type PCs and most terminals, either DB25 female to RJ-12 female (our product code FA044) or DE9 (“DB9”) female to RJ-12 female (our product code FA043), depending on your computer/terminal. (If your computer is an Apple or Sun model, call Black Box for technical support.)

Take these steps:

1. Plug one end of the cable into the RS-232 serial port on the single or master ServManager’s rear panel, and the other end of the cable into the RJ-12 female connector on the appropriate adapter.

CAUTION!

Serial cabling in excess of 50 feet (15.2 m) should be routed with caution. The maximum cable length depends upon the construction of the cable and its routing. For extended runs, shielded cable should be used. Avoid routing near fluorescent lights, air-conditioning compressors, or machines that may create electrical noise. If you experience a lot of data errors, use shorter cables. The ServManager’s data rate of 9600 bps cannot be changed to alleviate this problem.

2. Connect the adapter to one of the computer’s (or terminal’s) COM ports.

4.5.2 SWITCHING PORTS REMOTELY (OPTIONAL)

To switch ports on a ServManager from a remote computer or terminal attached to the ServManager’s RS-232 port, take these steps:

1. Set your computer for serial communication at 9600 bps, no parity, 8 data bits, and 1 stop bit.
2. To switch the ServManager to a different port, type or send the desired port number followed by [ENTER] (a return).

NOTES

If the single or master ServManager is a very old unit, you might need to type or send a number *one less than* the desired port number (“0” for Port 1, “1” for Port 2, etc.).

If the master unit is a very old ServSwitch, you might need to type or send an “@” [“at sign”] character before typing or sending the port number.

If you type or send a “?” (question mark) rather than a port number, the single or master Serv unit will send the number of the currently selected port, in ASCII decimal format, back to the remote computer or terminal.

4.5.3 UPGRADING THE FIRMWARE (FLASH MEMORY)

The ServManager has flash memory, which means its firmware may be reloaded (upgraded) in order to support new features or fix any problems in its operation. (For firmware-revision information, and for how to obtain a copy of the most recent revision if necessary, call your supplier for technical support.) You have a choice of two data rates at which to load the flash file. Both require an 8-bit, no-parity data format. To perform the flash-loading procedure, you must press one of these front-panel keypad keys when you turn ON the ServManager:

- For a flash load at **57,600 bps (baud)**, press the **MENU** key at power-up.
- For a flash load at **9600 bps (baud)**, press the **1** key at power-up.

The display should show:

```
Waiting for file
at xxxxx baud
```

At this point, send the proper file from your computer to the ServManager through the ServManager's RS-232 port. (The computer must be attached to the ServManager with the proper cable and adapter—see **Section 4.5.1.**) If the computer is an IBM type PC running DOS, enter the command "COPY [filename] COM1" or "COPY [filename] COM2" depending on which of the PC's serial ports is connected to the ServManager. If the computer is another type, or if you are using a different operating system, use the procedure for sending or copying a file out of the serial port.

If the file is correct, this message will appear as the file is being loaded:

```
Receiving file
◆◆◆◆◆
```

The ◆'s are progress indicators that accumulate as the file is sent. Once the file is completely and successfully received, this message will appear:

```
Receive successful
Hit enter to program
```

Hitting ENTER will cause the following message to appear

```
Programming flash
◆◆◆◆◆
```

In this case, the ◆'s are progress indicators that accumulate as the flash is programmed. Once programming is complete, this message will appear:

```
Verifying flash
◆◆◆◆◆
```

In this case, the ◆'s are progress indicators that accumulate as the flash is verified. If programming and verifying are successful, this message appears:

```
Verify successful
Hit enter to boot
```

Hitting ENTER will cause the ServManager to power up in normal operation. Observe the new revision number as it powers up, to verify that the correct file was loaded.

You may receive any of the following error messages when the ServManager tries to receive the file:

```
Checksum error
Hit enter to proceed
```

```
Data error
Hit enter to proceed
```

```
Record error
Hit enter to proceed
```

If any of these errors occur, it means that either the RS-232 cable is bad, the file-transfer parameters aren't set correctly, the transmit or receive level is bad, or the computer or ServSwitch has a hardware problem.

NOTE

Normally only two wires are necessary to the ServManager, receive and ground. However, if you are using DOS to copy the configuration file to the ServManager, DOS *must* see a high DSR signal input (Pin 6 on PC COM ports, whether they are DE9 or DB25 type) in order for the copy command to work. The ServManager provides this signal using RTS (Pin 6) output from its RS-232 Port.

Hit ENTER to continue and you should get the following message.

```
Receive failed
Try again ?  Yes
```

You can hit the up- or down-arrow to change the "Yes" to "No." If you enter "Yes," you go back to the beginning of the receive-file procedure. If you enter "No," the ServManager proceeds with its normal power-up operation.

If verifying fails, you will get the following message:

```
Verify failed
Hit enter to program
```

At this point you can either hit ENTER and try again or turn OFF the ServManager and start over. (Make sure that what you are trying to load is the actual updated firmware program itself, and not an archived or compressed version of it.) Depending on what was loaded, it is possible that the ServManager's kernel (flash loading utility), program, or configuration data is corrupt. If you continue to get this error, then either the program file or configuration data is corrupt, or there is a kernel, flash-memory, or other software or hardware problem in the box; call Black Box for technical support.

5. Troubleshooting

The first two sections of this chapter discuss things to try when problems arise in a ServManager system. If the trouble you're having with the ServManager is something you haven't seen before, or if the trouble seems minor, try the procedures detailed in **Sections 5.1** and **5.2** before doing anything else.

The third section of this chapter suggests possible causes and solutions to frequently encountered problems; if the trouble is chronic, see **Section 5.3**.

Sections 5.4 and **5.5** discuss what's involved in calling Black Box and shipping your ServManager.

CAUTION!

We strongly recommend that you avoid opening the ServManager's cover. If for some reason you need to do this, be very careful to replace each screw in the same hole you took it from. There are three different lengths of screws involved, and putting a longer screw in a hole reserved for a shorter screw can ground the chassis to the circuit boards and cause serious damage.

5.1 Diagnostic Information

If you're having difficulty with the ServManager, there is always the possibility that it has accidentally been configured or set incorrectly. To receive diagnostic information from a ServManager, including the current settings of its parameters, take these steps:

1. Establish a remote-control connection with the ServManager as described in **Sections 4.5.1** and **4.5.2**. (If you want to be able to save or print this information, or even see the first part of it before it scrolls off the screen, you should connect the ServManager to a computer running a terminal-emulator program set to "capture" mode.)
2. Turn OFF the ServManager, then press and hold down the ENTER key on its front-panel keypad while you turn the ServManager back ON. The ServManager should immediately begin self-testing and sending ASCII text of a diagnostic report out of its RS-232 port.

You might want to compare the reported conditions with the default and possible settings listed in **Appendix A** and the command descriptions in **Sections 4.2** and **4.3**.

5.2 Restoring Factory-Default Settings

Something that often helps to clear up problems in a ServManager system is resetting the ServManager to its factory defaults. Follow these steps *carefully*:

1. Turn OFF the ServManager. Make sure all of the submasters attached to it and all CPUs directly or indirectly connected to it are turned OFF.
2. Press and hold down the → (right-arrow) key on the ServManager's front-panel keypad while you turn the ServManager back ON. The ServManager's display will eventually show:

```
Configuration reset
Hit enter to proceed
```

3. Press ENTER. One of the following messages will appear:

```
Reset successful
Hit enter to proceed
```

```
Reset failed
Hit enter to proceed
```

4. If the reset succeeded, hit ENTER and the ServManager will resume normal operation; go on to step 5. If the reset failed, you can hit ENTER to try again—the failure might have been a fluke. If several reset attempts all fail, however, go back to step 1 and start over. If there is a power-up error, or if your reset attempts continue to fail, the ServManager probably has a hardware problem; call Black Box to arrange for the unit to be repaired.
5. Select Port 1 on the ServManager. Power up the device on Port 1; if the device is a CPU, wait for it to go completely through its boot-up process. Then select Port 2, power up that device, and so on.
6. Starting with the lowest-numbered CPU and proceeding to the highest-numbered one, power up the CPUs on the ServManager's submasters one at a time, waiting for each to boot completely before going to the next.

Now reconfigure the ServManager to your desired settings. If you're still having difficulty, refer to **Section 5.3**. If it doesn't help you to solve your problem, call Black Box for technical support.

5.3 Common Problems

5.3.1 A CPU CONNECTED TO YOUR SERVMANAGER OR A SUBMASTER DOESN'T BOOT, AND YOU GET A KEYBOARD OR MOUSE ERROR

- A.** First make sure your ServManager and (if one is involved) your submaster are plugged in and powered up.
- B.** If the ServManager and submaster are ON, check the master's configuration. The keyboard or mouse might not be set correctly for that CPU.
- C.** If the configuration is OK, check your cables. Tighten any loose connections. For PS/2 type equipment, if the keyboard and mouse strands of either the CPU cable or the MKM cable have been reversed, plug them into the proper ports.
- D.** If you don't find a cable error, try swapping in different keyboards and/or mice one at a time. If the problem goes away when you substitute a device, the old one might have gone bad.
- E.** If swapping input devices doesn't solve the problem, begin swapping your cables one at a time. If the problem goes away when you substitute a cable, the old cable is probably defective.
- F.** If swapping cables doesn't solve the problem, try plugging the CPU into a different CPU port on the ServManager or submaster. If the CPU boots when it's connected to a different port, the old port is probably defective.
- G.** If swapping ports doesn't solve the problem, try plugging a known-good keyboard and mouse of the proper type directly into the CPU that's having the problem. If the CPU boots, the ServManager or submaster might be defective; call Black Box for technical support.
- H.** If the CPU still doesn't boot, the CPU's keyboard or mouse port (or other components) might be defective. (If the CPU's Power LED doesn't light, the fuse on the CPU's motherboard might be blown.) If you still have them, plug that CPU's original monitor, keyboard and mouse into it and try again. If the CPU does *not* boot with its original equipment, something in the CPU is defective; call the CPU's manufacturer. If the CPU *does* boot, there is some kind of unusual mismatch between that CPU and the shared monitor, keyboard, or mouse; call Black Box for technical support.

5.3.2 YOU CAN'T SWITCH PORTS FROM THE KEYBOARD

A. Can you do *anything* from the keyboard? If not, the keyboard might not be set properly for the currently selected CPU. Use the ServManager's front-panel display to make sure the proper "Keyboard" setting and the proper "CPU keyboard/mouse" setting are selected.

B. If the configuration is OK, the keyboard strand of your MKM Adapter Cable has probably come loose. Reconnect it.

C. The ServManager might have lost power for less than three seconds. (This can cause the keyboard to lock up.) Disconnect the keyboard and plug it back in.

D. The keyboard mode that the currently selected CPU port is set for doesn't match the mode that the CPU on that port expects. Issue the Set Keyboard Mode command, or use the front-panel keypad, to change the port's mode (see **Section 4.3.7**). Sometimes this situation can confuse the CPU or keyboard so badly that it is necessary to reboot the CPU or to reset the keyboard by unplugging it and plugging it back in.

E. For PS/2 type equipment, if the keyboard and mouse strands of either the CPU cable or the MKM cable have been reversed, plug them into the proper ports.

F. You might be using the keyboard incorrectly. Make sure to use the *left* Control key to start port-switching commands. Make sure to use the numeric keys at the top of the keyboard rather than the numeric keypad when you type in port numbers. Make sure to release the Control key before you start typing in a port number. Make sure you don't wait too long before you enter a port number. Make sure you don't accidentally hit keys such as Shift or Alt.

5.3.3 CHARACTERS THAT YOU TYPE COME UP WRONG OR MISSING

The keyboard mode that the currently selected CPU port is set for doesn't match the mode that the CPU on that port expects. See item D under the previous section.

5.3.4 YOUR MOUSE DRIVER DOESN'T LOAD

A. The mouse might not be set properly for that CPU. Use the ServManager's front-panel display to make sure the proper "Mouse" setting and the proper "CPU keyboard/mouse" setting are selected.

B. RS-232 serial mouse: Make sure that you're using the right COM port, and that the mouse driver is looking for the correct port.

C. PS/2 mouse: To recognize the mouse, the CPU must be directly connected to it, or indirectly connected to it through the ServManager and (if one is involved) the submaster, at boot-up time. Make sure that all cables are properly seated and that the ServManager and submaster are ON, then reboot the CPU.

D. IBM type mouse (PS/2 or serial): Your mouse driver might be old or incompatible with your mouse. Try the latest version of the Microsoft mouse driver.

5.3.5 YOU CAN'T ACCESS ALL THE FUNCTIONS OF YOUR MOUSE

A. What type of mouse is it? If it is any other type than a standard Apple or Sun mouse, or one of the PC mouse types listed in **Section 4.3.6.B** on page 42, chances are that the ServManager doesn't support it.

B. If your mouse is a Microsoft BallPoint, you need the latest version of the Microsoft mouse driver.

C. If your mouse is a Logitech™ mouse, the ServManager supports the two-button models but not the three-button models.

5.3.6 YOUR PS/2 MOUSE GETS OUT OF SYNC

Cabling might have been disturbed during mouse movement. Issue the Send Null Byte command (see **Section 4.3.14**) once or twice to get the mouse back in sync. You need the latest version of the Microsoft mouse driver to stop this from happening.

5.3.7 YOUR MOUSE DOESN'T MOVE THE POINTER/CURSOR

- A.** The mouse might not be set properly for that CPU. Use the ServManager's front-panel display to make sure the proper "Mouse" setting and the proper "CPU keyboard/mouse" setting are selected.
- B.** If your mouse is a PS/2 type, it might not have been connected to the ServManager when the ServManager was turned ON. It might also have been disconnected and reconnected after the ServManager was turned ON.
- C.** Your mouse must be connected to a powered ServManager when the CPUs are booted and when mouse applications are run. Try exiting and re-entering your application; if this doesn't work, issue the Reset command (see **Section 4.3.13**).

5.3.8 YOUR MONITOR DISPLAY IS FUZZY

- A.** Check the settings of your monitor, especially the sharpness control.
- B.** If you can't solve the problem by changing the monitor settings, you might have run cable too far. With IBM type equipment, maximum distance of original Serv cable from any CPU to the shared monitor, keyboard, and mouse is 25 ft. (7.6 m). With Apple or Sun equipment, maximum distance of standard coaxial cable from any ServManager to any attached device is 100 ft. (30.5 m). The distance you can run will be less than the maximum if you are using SVGA video on original Serv cables or if you are cascading submasters. If you're running IBM video, you might need to upgrade from original Serv cables to coaxial cables that carry the video signal better. If you are already using coax cables for IBM video, you might need to add Station Extenders (our product codes AC253 etc.); call Black Box for technical support. See **Section 4.1.3** and **Appendix B**.

5.3.9 YOUR VIDEO IS NOT SYNCHRONIZED OR IS THE WRONG COLOR

- A.** If you are trying to use an IBM 9515, 9517, or 9518 monitor, you need special cables to carry the video correctly. Call Black Box for technical support.
- B.** Check the settings of your monitor, especially the sync or color controls.
- C.** Your monitor might not be capable of synching to the selected video resolution or frequency (refresh rate). Try a lower resolution or frequency or a more powerful monitor.

- D.** If your CPU is producing composite sync and your monitor accepts only separate horizontal and vertical sync (or vice versa), try swapping in a matching monitor or CPU, or a monitor that will accept both sync types. If this is not an option, call Black Box for technical support; we might be able to give you a quote on a sync converter and special cabling.
- E.** If the video problem is not centered on the monitor, check the video strands of your cables. Tighten any loose connections.
- F.** If no cable connectors are loose, begin swapping your cables one at a time. If the problem goes away when you substitute a cable, the old cable is probably defective.
- G.** If swapping cables doesn't solve the problem, try plugging the CPU into a different CPU port on the ServManager or submaster. If the problem goes away when the CPU is connected to a different port, the old port is probably defective.

5.3.10 YOUR VIDEO IS OK IN LOW-RESOLUTION MODE, BUT YOU CAN'T GET INTO HIGH-RESOLUTION MODE

- A.** If you're using XGA, you *must* use coaxial cables (see **Section 4.1.3** and **Appendix B**).
- B.** Check your video driver. It might not be set up correctly for your desired resolution. This might be true even for Mac or Sun CPUs.

5.3.11 YOU CAN'T SEEM TO SCAN OR SWITCH TO ONE OR MORE OF YOUR CPUs

- A.** The Units value might not be set correctly. (If any of the CPUs you *can* access are receiving garbage characters, this is a good indicator.) Try setting it now (see **Section 4.3.10**).
- B.** The Maximum Ports or Width value might not be set correctly. Try setting it now (see **Sections 4.3.8** and **4.3.9**).

5.3.12 ONE OR MORE OF YOUR IBM COMPATIBLE CPUs LOCK UP WHEN YOU LOAD WINDOWS 3.X

The usual cause of this problem is that the affected CPUs are set to load a Logitech or other type of mouse driver when Windows starts up. Set the CPU to load the generic Microsoft mouse driver instead.

5.3.13 ONE OR MORE OF YOUR CPUs HAS PROBLEMS EXITING WINDOWS 3.X

If an IBM compatible CPU running Windows 3.x locks up or (if it's also running EMM386®) displays "EMM386 EXCEPTION ERROR #06" when you try to exit Windows, this is probably what causes it: Windows tries to unload its mouse drivers and reinstate any DOS drivers specified in AUTOEXEC.BAT and CONFIG.SYS. The ServManager sees this as a reboot and sends a [CTRL] [M] to the CPU to set the mouse driver for Microsoft mouse compatibility. If the CPU doesn't actually load a mouse driver in DOS, it will crash or at least display the EMM386 error when it receives the [CTRL] [M]. Make sure all of your CPUs load mouse drivers in *both* operating-system environments, even if you don't use a mouse in DOS.

5.3.14 THE SERVMANAGER DOESN'T WORK WITH YOUR IBM COMPATIBLE DOCKING STATION

At this time the ServManager does *not* support docking stations for IBM compatible portable computers.

5.3.15 THE SERVMANAGER DOESN'T WORK WITH YOUR DONGLE-PROTECTED SOFTWARE

At the time of this writing, the ServManager does *not* support dongles (the devices required to be inserted into the keyboard line by some software for copy protection).

5.4 Calling Black Box

If you determine that your ServManager is malfunctioning, *do not attempt to alter or repair the unit*. It contains no user-serviceable parts (and see the Caution notice on page 68). Call Black Box Technical Support at (724) 746-5500.

Before you do, make a record of the history of the problem. We will be able to provide more efficient and accurate assistance if you have a complete description, including:

- the nature and duration of the problem.
- when the problem occurs.
- the components involved in the problem.
- any particular application that, when used, appears to create the problem or make it worse.

5.5 Shipping and Packaging

If you need to transport or ship your ServManager:

- Package it carefully. We recommend that you use the original container.
- If you are shipping the ServManager for repair, make sure you include its power supply and the adapter cables you're using with it. If you are returning the ServManager, make sure you include its manual as well. Before you ship, contact Black Box to get a Return Materials Authorization (RMA) number.

Appendix A: NVRAM Factory Defaults

The table below shows, for the ServManager's saveable options, the default values stored in nonvolatile memory (NVRAM) when the ServManager is shipped from the factory. It also shows what commands or actions can change these settings for the ServManager's current operating period, as well as what commands or actions can save changed settings to NVRAM, so that they become the new defaults.

Option	Factory-Default Setting	To Change	To Save Changes
Caps/Scroll/ Num Lock	Num Lock ON (fixed)	Select port, then press the corresponding button on the keyboard	Can't be saved
Scan	OFF	Start/end scan with the ServManager's keypad or type [CTRL] S (to turn ON) or [CTRL] X (to turn OFF)	Can't be saved
Scan-Delay Time	5 seconds	Use the ServManager's keypad or type [CTRL] Txxx [ENTER] (xxx = 1 to 999, time in seconds)	"Save config." or [CTRL] K
Power-On Scan	Off	Use the ServManager's keypad (configuration menu)	"Save config."
Keyboard Type	PC	Use the ServManager's keypad (configuration menu)	"Save config."
Mouse Type	PS/2	Use the ServManager's keypad (configuration menu)	"Save config."
CPU Keyboard/ Mouse (Keyboard Mode)	PC Mode 2 / PS/2	Use the ServManager's keypad or select port, then type [CTRL] Mx (x = 1 to 9)	"Save config." or [CTRL] K
CPU Name	CPU xxx (xxx = port number)	Use the ServManager's keypad or (at CPU prompt or with CPU in text-display state) type [CTRL] [F12]	"Save config." or [CTRL] K

APPENDIX A: NVRAM Factory Defaults

Option	Factory-Default Setting	To Change	To Save Changes
Video-Blank Time (Screen Saver's Delay Time)	OFF (disabled, set to zero)	Use the ServManager's keypad or type [CTRL] Vxxx [ENTER] (xxx = any 1- to 3-digit number, time in seconds)	"Save config." or [CTRL] K
Keyboard Typematic	43 (delay of 1/2 second, rate of 10.9 characters per second)	Use the ServManager's keypad or type [CTRL] Axxx [ENTER] (xxx = 0 to 127; see Section 4.3.11)	"Save config." or [CTRL] K
Maximum Ports	No. of CPU ports on unit	Use the ServManager's keypad or type [CTRL] Pxxx [ENTER] (xxx = 2 to 256)	"Save config." or [CTRL] K
Width	16	Use the ServManager's keypad or type [CTRL] Wxxx [ENTER] (xxx = 2 to 255)	"Save config." or [CTRL] K
Units	0	Use the ServManager's keypad or type [CTRL] Uxxx [ENTER] (xxx = 2 to 255)	"Save config." or [CTRL] K

Appendix B: Product Codes for Cables

The table below and on the next page lists the product codes for all the types of cables we currently offer for use with the ServManagers. The four digits that follow the dash in each product code indicate how long each cable is in feet (one foot = 30.5 cm).

For some cables, xxx's are shown in place of the last three digits of the product code because the cables come in several stock lengths. For standard CPU adapter cables, these last three digits can be "005," "010," or "020" for 5-foot (1.5-m), 10-foot (3-m), or 20-foot (6.1-m) cables respectively. For coaxial cables, these last three digits can be "005," "010," "020," "050," "075," or "100" for 5-foot (1.5-m), 10-foot (3-m), 20-foot (6.1-m), 50-foot (15.2-m), 75-foot (22.9-m), or 100-foot (30.5-m) cables respectively.

The table also lists the product codes for the Station Extenders and their cables. Depending on your equipment—which must be IBM type—and the video resolution you're using, you might be able to use the Extenders to connect the ServManager to monitor/keyboard/mouse stations or CPUs as much as 200 ft. (61 m) away.

If your monitor/keyboard/mouse-sharing system has cabling requirements that can't be met by what you see here, call Black Box for a possible quote on custom cables or adapters.

Standard Monitor/Keyboard/Mouse Adapter Cables:

Monitor Type (Connector on Cable)	Keyboard Type (Connector on Cable)	Mouse Type (Connector on Cable)	Product Code
VGA (DE15 female)	IBM AT (5-pin DIN female)	Serial RS-232 (DE9 male)	EHN052-0001
VGA (DE15 female)	IBM PS/2 (6-pin mini-DIN female)	PS/2 (6-pin mini-DIN female)	EHN054-0001
Mac (DA15 female)	Mac (4-pin mini-DIN female)	N/A	EHN210-0001
Sun (D13W3 female)	Sun (6-pin mini-DIN female)	N/A	EHN200-0001

Coaxial Monitor/Keyboard/Mouse Adapter Cables:

Monitor Type (Connector on Cable)	Keyboard Type (Connector on Cable)	Mouse Type (Connector on Cable)	Product Code
VGA (DE15 female)	IBM AT (5-pin DIN female)	Serial RS-232 (DE9 male)	EHN270-0xxx
VGA (DE15 female)	IBM PS/2 (6-pin mini-DIN female)	PS/2 (6-pin mini-DIN female)	EHN273-0xxx

APPENDIX B: Product Codes for Cables

Standard CPU Adapter Cables:

Video Type (Connector on Cable)	Keyboard Type (Connector on Cable)	Mouse Type (Connector on Cable)	Product Code
VGA (DE15 male)	IBM AT (5-pin DIN male)	Serial RS-232 (DE9 female)	EHN048-0xxx
VGA (DE15 male)	IBM PS/2 (6-pin mini-DIN male)	PS/2 (6-pin mini-DIN male)	EHN051-0xxx
Mac (DA15 male)	Mac (4-pin mini-DIN male)	N/A	EHN215-0xxx
Sun (D13W3 male)	Sun (6-pin mini-DIN male)	N/A	EHN205-0xxx

Coaxial CPU Adapter Cables:

Video Type (Connector on Cable)	Keyboard Type (Connector on Cable)	Mouse Type (Connector on Cable)	Product Code
VGA (DE15 male)	IBM AT (5-pin DIN male)	Serial RS-232 (DE9 female)	EHN271-0xxx
VGA (DE15 male)	IBM PS/2 (6-pin mini-DIN male)	PS/2 (6-pin mini-DIN male)	EHN272-0xxx

Original ServSwitch-to-ServSwitch Expansion Cable: EHN055-0001

Coaxial ServSwitch-to-ServSwitch Expansion Cable: EHN274-0xxx

Station Extenders:

CPU to ServManager (RS-232 Mouse): AC254A

ServManager to Station (RS-232 Mouse): AC255A

CPU to ServManager (PS/2 Style Mouse): AC257A

ServManager to Station (PS/2 Style Mouse): AC258A

Station-Extender Cables: EHN250-0xxx, where "xxx" = 050, 100, 150, or 200

Appendix C: Error Messages

If any errors occur during power-up diagnostics, messages will appear on the ServManager's front-panel display. Here are the messages you might see and what they mean. If you ever see any of them, you'll probably need to call Black Box for technical support.

Message Displayed	Description and Necessary Actions
Kernel corrupted	Kernel portion of flash memory has wrong checksum. (It might be possible to flash-reload it.) The unit halts and must be repaired or reloaded.
Static ram bad	The static RAM (memory) chip is bad. The unit halts and must be serviced.
Program corrupted	Program portion of flash memory has wrong checksum. (It may be possible to flash-reload it.) The unit halts and must be repaired or reloaded.
Configuration bad	Configuration portion of flash memory has wrong checksum. (It may be possible to reset it to factory default using the reset-to-defaults procedure in Section 5.2 .)
Reset failed Hit enter to proceed	Configuration portion of flash memory cannot be reloaded. Hit ENTER to retry. If reload consistently fails, unit must be serviced.

Appendix D: Pinout of RS-232 Port

The table below shows the pinout of the ServManager's RJ-12 ("6-wire RJ-11") female RS-232 port.



Pin	Signal Name	Abbrev.	Direction	Description
1	Data Set Ready	DSR	Input	Reserved (not used)
2	Data Terminal Ready	DTR	Output	Pulled high with 1-K Ω resistor
3	Transmit Data	TXD	Output	Serial data from port
4	Signal Ground	SGND	N/A	DC ground reference
5	Receive Data	RXD	Input	Serial data to port
6	Request to Send	RTS	Output	Pulled high with 1-K Ω resistor

TRADEMARKS USED IN THIS MANUAL

Apple, Mac, Macintosh, and TeachText are registered trademarks of Apple Computer, Inc.

AT, IBM, OS/2, PS/2, RS/6000, and ThinkPad are registered trademarks, and PC/XT is a trademark, of IBM Corporation.

Logitech is a trademark of Logitech, Inc.

Microsoft and Windows are registered trademarks of Microsoft Corporation.

Sun Microsystems is a registered trademark of Sun Microsystems.

UNIX is a registered trademark of Unix System Laboratories, Inc.

All other trademarks are the property of their respective owners.

NOTES

NOTES



© Copyright 1997. Black Box Corporation. All rights reserved.

1000 Park Drive • Lawrence, PA 15055-1018 • 724-746-5500 • Fax 724-746-0746