

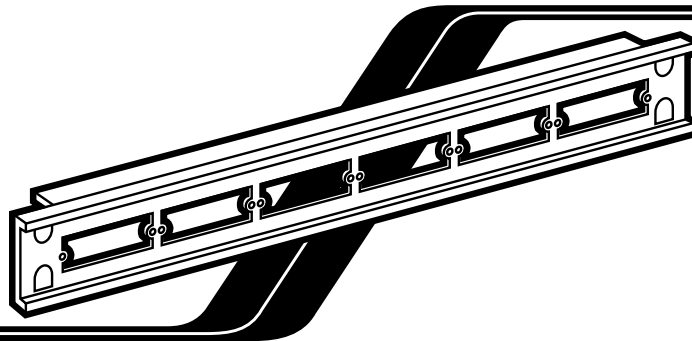

Rackmount Kit for ServSwitch™ Brand



Use this Rackmount Kit to mount as many as six Local Modules, Remote Modules, or Dual Remote Modules of a ServSwitch™ Brand CAT5 Broadcast Video System (product codes ACL8501A, ACL8502A, and ACL8503A respectively) in a 19" equipment rack.

To mount a Module in a rack using this Kit, first decide which way you want the unit to face: Each Module can be mounted with either the left or right side facing forward. (For most people, it's most convenient to have the RJ-45 socket[s] facing forward, but your application might call for them to face the rear of the rack.)

Now take these steps, referring to Figure 1 on the back of this page:

1. Unscrew the two screws on either end of the side of the Module that you want to face forward.
2. Remove the bezel and loose side plate (but keep the bezel in storage if you think you might ever want to use the Module as a standalone unit again).
3. Put the exposed side of the Module against the *back* of the Rackmount Kit bracket (the side of the bracket on which the top and bottom flanges are longer). Line up the Module so that (a) the edges of its case are behind the edges of one of the mounting holes in the bracket, and (b) the two screwholes in the Module where you removed the screws match up with the screwholes in the bracket beside that mounting hole.
4. Take the Module's side plate that you removed earlier, place it against the *front* of the bracket, and line up its screwholes with the screwholes in the bracket beside that mounting hole.
5. Insert and tighten the screws through the plate, through the bracket, and back into the Module's case.
6. Secure the Kit bracket to the rack using your own screws, bolts, cage nuts, etc.

RACKMOUNT KIT FOR SERVSWITCH™ BRAND CAT5 BROADCAST VIDEO SYSTEM MODULES

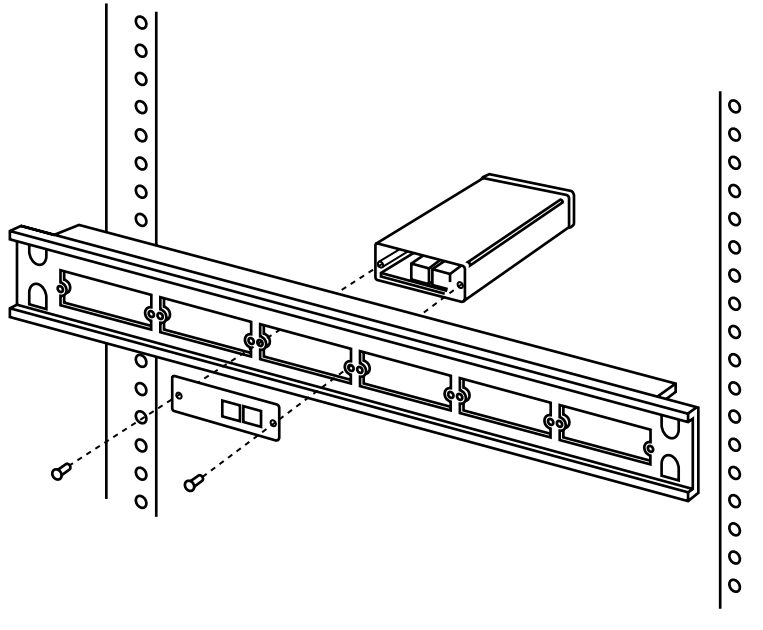



Figure 1. Rackmounting a Local or Remote Module (Dual Remote Module shown, with left side facing forward).

© Copyright 2000. Black Box Corporation. All rights reserved.

CUSTOMER SUPPORT INFORMATION

Order **toll-free** in the U.S.: Call **877-877-BBOX** (outside U.S. call **724-746-5500**)
FREE technical support 24 hours a day, 7 days a week: Call **724-746-5500** or fax **724-746-0746**
Mailing address: **Black Box Corporation**, 1000 Park Drive, Lawrence, PA 15055-1018
Web site: **www.blackbox.com** • E-mail: **info@blackbox.com**

BLACK BOX and the  logo are registered trademarks, and ServSwitch is a trademark, of Black Box Corporation.