



© Copyright 1995. Black Box Corporation. All rights reserved.

1000 Park Drive • Lawrence, PA 15055-1018 • 724-746-5500 • Fax 724-746-0746



OCTOBER 1995

PI720A-R2	PI720AE-R2
PI721A-R2	PI721AE-R2
PI722A-R2	PI722AE-R2
PI723A	PI724A
PI725A	PI726A
PI727A	PI728A

Multiport Spooler VII (4P, 8P, 12P)

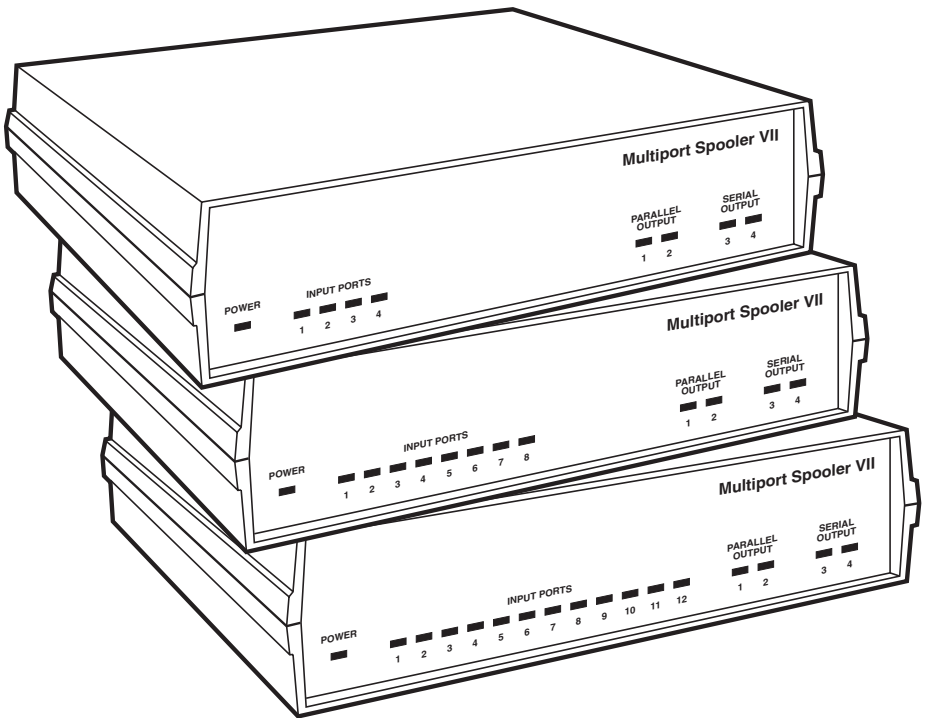

**CUSTOMER
SUPPORT
INFORMATION**

Order toll-free in the U.S. 24 hours, 7 A.M. Monday to midnight Friday: 877-877-BBOX
FREE technical support, 24 hours a day, 7 days a week: Call 724-746-5500 or fax 724-746-0746
Mail order: **Black Box Corporation**, 1000 Park Drive, Lawrence, PA 15055-1018
Web site: www.blackbox.com • E-mail: info@blackbox.com



FEDERAL COMMUNICATIONS COMMISSION AND CANADIAN DEPARTMENT OF COMMUNICATIONS RADIO FREQUENCY INTERFERENCE STATEMENTS

This equipment generates, uses, and can radiate radio frequency energy and if not installed and used properly, that is, in strict accordance with the manufacturer's instructions, may cause interference to radio communication. It has been tested and found to comply with the limits for a Class A computing device in accordance with the specifications in Subpart J of Part 15 of FCC rules, which are designed to provide reasonable protection against such interference when the equipment is operated in a commercial environment. Operation of this equipment in a residential area is likely to cause interference, in which case the user at his own expense will be required to take whatever measures may be necessary to correct the interference.

Changes or modifications not expressly approved by the party responsible for compliance could void the user's authority to operate the equipment.

This digital apparatus does not exceed the Class A limits for radio noise emission from digital apparatus set out in the Radio Interference Regulation of the Canadian Department of Communications.

Le présent appareil numérique n'émet pas de bruits radioélectriques dépassant les limites applicables aux appareils numériques de classe A prescrites dans le Règlement sur le brouillage radioélectrique publié par le ministère des Communications du Canada.

Any trademarks mentioned in this manual are acknowledged to be the property of the trademark owners.

NORMAS OFICIALES MEXICANAS (NOM) ELECTRICAL SAFETY STATEMENT

INSTRUCCIONES DE SEGURIDAD

1. Todas las instrucciones de seguridad y operación deberán ser leídas antes de que el aparato eléctrico sea operado.
2. Las instrucciones de seguridad y operación deberán ser guardadas para referencia futura.
3. Todas las advertencias en el aparato eléctrico y en sus instrucciones de operación deben ser respetadas.
4. Todas las instrucciones de operación y uso deben ser seguidas.
5. El aparato eléctrico no deberá ser usado cerca del agua—por ejemplo, cerca de la tina de baño, lavabo, sótano mojado o cerca de una alberca, etc..
6. El aparato eléctrico debe ser usado únicamente con carritos o pedestales que sean recomendados por el fabricante.
7. El aparato eléctrico debe ser montado a la pared o al techo sólo como sea recomendado por el fabricante.
8. Servicio—El usuario no debe intentar dar servicio al equipo eléctrico más allá a lo descrito en las instrucciones de operación. Todo otro servicio deberá ser referido a personal de servicio calificado.
9. El aparato eléctrico debe ser situado de tal manera que su posición no interfiera su uso. La colocación del aparato eléctrico sobre una cama, sofá, alfombra o superficie similar puede bloquear la ventilación, no se debe colocar en libreros o gabinetes que impidan el flujo de aire por los orificios de ventilación.
10. El equipo eléctrico debe ser situado fuera del alcance de fuentes de calor como radiadores, registros de calor, estufas u otros aparatos (incluyendo amplificadores) que producen calor.

11. El aparato eléctrico deberá ser conectado a una fuente de poder sólo del tipo descrito en el instructivo de operación, o como se indique en el aparato.
12. Precaución debe ser tomada de tal manera que la tierra física y la polarización del equipo no sea eliminada.
13. Los cables de la fuente de poder deben ser guiados de tal manera que no sean pisados ni pellizcados por objetos colocados sobre o contra ellos, poniendo particular atención a los contactos y receptáculos donde salen del aparato.
14. El equipo eléctrico debe ser limpiado únicamente de acuerdo a las recomendaciones del fabricante.
15. En caso de existir, una antena externa deberá ser localizada lejos de las líneas de energía.
16. El cable de corriente deberá ser desconectado del cuando el equipo no sea usado por un largo periodo de tiempo.
17. Cuidado debe ser tomado de tal manera que objetos líquidos no sean derramados sobre la cubierta u orificios de ventilación.
18. Servicio por personal calificado deberá ser provisto cuando:
 - A: El cable de poder o el contacto ha sido dañado; u
 - B: Objetos han caído o líquido ha sido derramado dentro del aparato; o
 - C: El aparato ha sido expuesto a la lluvia; o
 - D: El aparato parece no operar normalmente o muestra un cambio en su desempeño; o
 - E: El aparato ha sido tirado o su cubierta ha sido dañada.

Contents

Chapter	Page
1. Specifications	6
2. Introduction	8
2.1 Getting Started	8
2.2 Product Features	8
2.3 The Complete Package	9
2.4 The Multiport Spooler VII Illustrated	10
3. Hardware Installation	11
3.1 Connecting PCs to the Multiport Spooler VII	11
3.2 Connecting Printers to the Multiport Spooler VII	18
3.3 Final Steps	22
4. Software Installation and Configuration	23
4.1 The Windows SETUP Program	23
4.2 System-Administrator Setup	24
4.3 Windows Workstation Setup	34
4.4 The Parallel-Port Print Test	36
5. Operation	40
5.1 Functions of the Control Program	40
5.2 Sharing a Single Printer	41
5.3 Printing from a Windows Application	44
5.4 Sharing Multiple Printers	45
5.5 Printing to a Local Printer Attached Directly to Your PC	48
5.6 Diagnostic and Maintenance Functions of the Control Program	51
6. Daisy chaining	55
6.1 Installing the Cables	55
6.2 System-Administrator Setup	57

Chapter or Appendix	Page
7. Troubleshooting	61
7.1 If a Connection or Print Test Fails	61
7.2 If You Have Problems Printing from Windows Applications	63
7.3 If a Job Prints as Garbage	65
7.4 If the Printer Takes Too Long to Print Documents	66
7.5 If You Have Printer-Selection Problems	67
7.6 Calling Your Supplier	69
7.7 Shipping and Packaging	70
Appendix A: Installation for DOS-Only Machines	71
A.1 Initial Steps	71
A.2 Printer Selection in DOS	72
Appendix B: Cable and Adapter Pinouts	73
B.1 The Cables and Adapters Illustrated	73
B.2 Modular-Adapter Pinouts	74
B.3 Cable Pinouts	77
Appendix C: Memory Expansion	78
C.1 Multiport Spooler VII Memory	78
C.2 Installing Memory-Expansion Modules	79
Appendix D: Direct Commands	80
D.1 Sending Commands Using the DOS ECHO Instruction	81
D.2 Command Format	82
D.3 Command Descriptions	82
D.4 Quick Reference	100
Glossary	102
Index	107
Trademarks Used in This Manual	116

1. Specifications

**System Hardware
Required —**

Computers: IBM PC/XT, AT, PS/2, or compatible;
other types of computers can be connected, but
must be permanently assigned to one printer

**System Software
Required —**

System administrator's PC: Windows 3.1 or higher;
Other PCs: Windows 3.1 or higher or DOS 3.3
or higher; other operating systems can be
connected, but their host computers must
be permanently assigned to one printer

**System Memory
Required —**

During software installation: 4 MB on each
computer;
After installation: Negligible amounts on each
computer

**Disk Space
Required —**

613 KB on each PC

Interfaces —

IBM PC parallel, proprietary serial

Data Format —

8 data bits, no parity, one stop bit (fixed, *not* user-
selectable)

Flow Control —

Input: Hardware (DTR/DSR) or software
(robust X-ON/X-OFF), user-selectable;
Output: Hardware (DTR/DSR) only

Data Rate —

Input ports: Up to 115.2 Kbps;
Serial output ports: Up to 38.4 Kbps

Throughput —

Parallel output ports: Up to 22,000 cps

Memory —

256K standard, upgradable to 16.2 MB

User Controls —

Rear-mounted recessed reset button

Indicators —	PI720A: (8) Activity LEDs, (1) Power LED; PI721A: (12) Activity LEDs, (1) Power LED; PI722A: (16) Activity LEDs, (1) Power LED
Connectors —	All models: (2) DB25 female for parallel output, (2) RJ-12 (six-wire RJ-11) female for serial output; PI720 models: (4) RJ-12 female for data input; PI721 models: (8) RJ-12 female for data input; PI722 models: (12) RJ-12 female for data input
Power —	PI720A-R2, PI721A-R2, PI722A-R2: Input: 120 VAC, 60 Hz at 177 mA; Output: 9 VAC at 1.4 A; Consumption: 20 watts; PI720AE-R2, PI721AE-R2, PI722AE-R2: Input: 230 VAC, 50 Hz at 225 mA; Output: 9 VAC at 1.4 A; Consumption: 20 watts
MTBF —	10,000 hours
Size —	2.5"H x 9.8"W x 7.3"D (6.4 x 24.9 x 18.5 cm)
Weight —	3 lb. (1.4 kg)

2. Introduction

2.1 Getting Started

Installing, configuring, and using your Multipoint Spooler VII printer-sharing device can be easy and straightforward if you follow the instructions in this manual. However, if you don't enjoy reading manuals (and we don't blame you if you don't!), you might want to just refer to the instructions and on-line help that we've packed into the included software program. (Please make sure you use the proper types of cables and adapters for your connections—see **Sections 3.1** and **3.2**. There is very little that can go wrong with the installation if the cables and adapters are good and you connect them correctly.)

The process of installation will involve setting up a system administrator on input port 1. The system administrator's PC must have Microsoft® Windows™ version 3.1 or later installed on it. The system administrator will configure all of the users and name all of the printers to be installed on the system.

Any Spooler users with Windows can load a printer-selection TSR by running the Windows program **SETUP.EXE**. If you'll be putting users on the Spooler system who have DOS but not Windows, they can still load this TSR by running **INSTALL.EXE** instead of **SETUP.EXE**.

2.2 Product Features

- The Spooler is available in models with 4, 8, or 12 input ports. These inputs are serial, so users can send data to print across long distances.
- You can individually configure each input port's data rate and flow-control (handshaking) methods. You can set flow control to either DTR/DSR or robust X-ON/X-OFF. The available data rates for the input ports are 1.2, 2.4, 4.8, 9.6, 19.2, 38.4, 57.6, or 115.2 Kbps.
- Each model has two parallel and two serial output (printer) ports. The parallel ports are DB25 female connectors, just like the parallel ports on any IBM® PC or compatible; each port's throughput is 22,000 cps. The serial ports are RJ-12 (six-wire RJ-11) female connectors; they use DTR/DSR flow control and can transmit data at 1.2, 2.4, 4.8, 9.6, 19.2, or 38.4 Kbps.

- The included Windows software package provides easy system installation and printer selection.
- With a TSR in the included software, users can select printers by selecting printer drivers in Windows application software—the easiest one-step selection method available.
- The Multipoprt Spooler VII's Control program can also be used to configure and select local printers with this TSR.
- You can upgrade the Spooler's buffer memory to 16 MB using standard SIMMs.
- By daisy chaining up to nine Multiport Spooler VIIs, you can connect as many as 90 IBM PC, PC/XT™, AT®, PS/2®, or compatible computers to as many as 36 printers.

2.3 The Complete Package

Before continuing, please make sure that you received all of the items that should have been included in your Multiport Spooler VII package:

- (1) Multiport Spooler VII
- (1) AC power adapter
- (1) 3.5" software diskette
- (1) Copy of this user's manual

2.4 The Multiport Spooler VII Illustrated

The figures below show the rear panels of all three of the Multiport Spooler VII models.

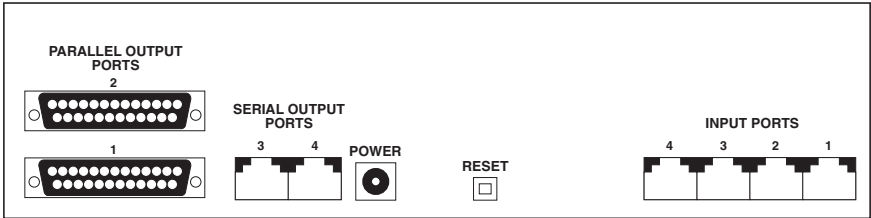

Figure 2-1. Rear view of Multiport Spooler VII-4P (PI720A/AE-R2).

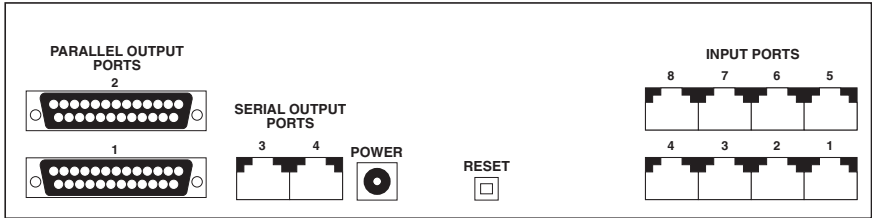

Figure 2-2. Rear view of Multiport Spooler VII-8P (PI721A/AE-R2).

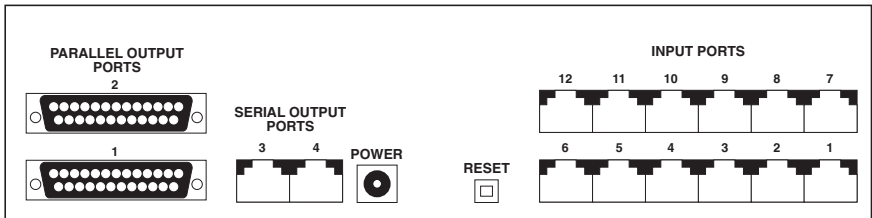

Figure 2-3. Rear view of Multiport Spooler VII-12P (PI722A/AE-R2).

3. Hardware Installation

There are four procedures involved in preparing a *single* Multiport Spooler VII for operation:

1. Installing the cables and adapters that connect the PCs to the MPS-VII.
2. Installing the cables and adapters that connect the MPS-VII to the printers.
3. Running the installation software on your PCs (**SETUP.EXE** for Windows machines, **INSTALL.EXE** for DOS-only machines).
4. Configuring the printers with the MPS-VII's Control program, and connecting the printer drivers to the Windows virtual ports LPT1.DOS, LPT2.DOS, and LPT3.DOS.

The first two procedures will be addressed in this chapter. Software installation and configuration will be addressed in the next two chapters.

If you will be installing *multiple* Multiport Spooler VIIs in a daisychain, see **Chapter 6**.

3.1 Connecting PCs to the Multiport Spooler VII

You can connect a PC to the Multiport Spooler VII either through one of the PC's serial ports or through one of its parallel ports. We recommend that you route the connection through one of the PC's serial ports; this type of installation is easier and is less likely to go wrong.

NOTE

If you look at the rear panel of the Multiport Spooler VII, you will see that the ports are labeled as inputs and outputs. The MPS-VII is controlled and configured from input port number 1. The PC connected to this port will be defined as the system administrator's. From the system administrator's PC you will perform the initial software installation and configuration for the entire MPS-VII system. This PC will also have the ability to reconfigure the system when users or printers are moved, added, replaced, or removed. The system administrator's PC should be the first one you install.

3.1.1 SERIAL INSTALLATION

You will notice that all of the input ports on the Multiport Spooler VII are RJ-12 (six-wire RJ-11) “telephone style” jacks, designed to support four- or six-wire cable. To connect your computers to the Multiport Spooler VII, either you must use special, expensive cable with different connectors on each end, or you must use standard cable plus modular adapters that plug into your PC’s serial port and convert it to an RJ-12 connector. Most people find the latter solution more economical.

3.1.1.A Choosing and Connecting the Modular Adapter

PCs normally have one of only two types of serial ports, DB25 male or DB9 male. In the illustration below, one of each type of serial port has been installed in a PC: The DB25 male connector is the long, almost rectangular connector farthest to the left, and the DB9 male is the connector just to the right and above it. (The DB25 female connector below the DB9 is a parallel port; the DB15HD female at the far right is a video port.)

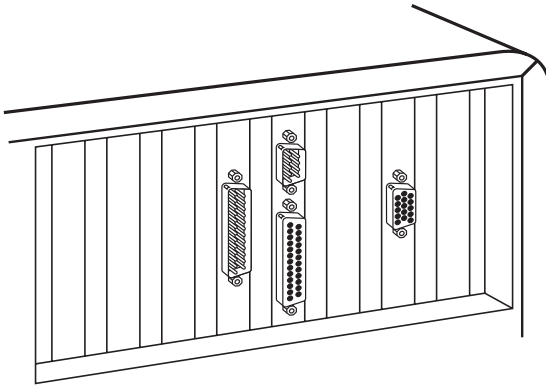

To determine which modular adapter you should use, follow these steps:

1. Check the serial ports on the back of your PC: Are they DB9 male connectors or DB25 male connectors? (Typically, older PCs or PC/XT computers will have DB25s, and newer AT computers will have DB9s.)
If the serial ports are DB25s, use a modular adapter with a DB25 female connector (PI723A):

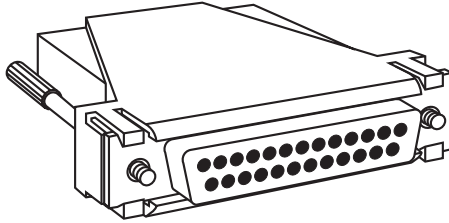

If the serial ports are DB9s, use a modular adapter with a DB9 female connector (PI724A):

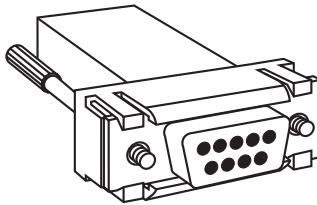

If you would rather, you can build your own modular adapters. Be aware, however, that it is very easy to get the pinning of the adapter wrong when you do this. If you choose to build your own adapters, make sure you follow the pinning described in **Appendix B**.

2. Securely plug the appropriate modular adapter into your PC's serial port. Finger-tighten the adapter's thumbscrews.

3.1.1.B Choosing the Modular Cables

Before you run serial cable between the PC and the MPS-VII, make sure you have—or can build—the right type of cable.

1. Flat Satin vs. Unshielded Twisted Pair (UTP)

For most data-communication applications, unshielded twisted-pair cable (a round type of cable in which wires are twisted around each other in pairs to minimize interference) performs better than flat satin cable (the flat type of cable that is often run between desktop modular telephones and wall jacks). With the Multipoint Spooler VII, either type of cable performs equally well for uninterrupted runs along the floor. However, any part of the cable run that you will be installing in the site's wall or ceilings (see the next paragraph) should be unshielded twisted pair. We also recommend UTP for any cable run over 50 ft. (15.2 m) long.

2. PVC vs. Plenum-Rated

If you will be installing cable in walls or ceilings, the cable should be unshielded twisted pair, as described in the previous paragraph. If you *will not* be running cable through plenums (air ducts or drop ceilings used as air-return systems), you can use UTP cables with everyday PVC (polyvinyl chloride) plastic jackets. If you *will* be running cable through plenums, you must use “plenum-rated” UTP cables with jackets made of material that does not give off toxic fumes when it burns.

3. Four-Wire vs. Six-Wire

The Multipoint Spooler VII's RJ-12 serial ports, and the RJ-12 ports on the modular adapters, can support either 4-wire or 6-wire cable. However, the MPS-VII only uses four leads: those represented by the four pins of an RJ-11 connector or the center four pins of an RJ-12 connector. Pins 1 and 6 of the MPS-VII's RJ-12 connectors are not connected to anything inside the MPS-VII, so the MPS-VII cannot support any wire, signal, or function carried by a 6-wire cable on those pins. Unless you already have 6-wire cable installed or on hand at your site, we recommend that you use 4-wire cable.

4. Straight-Through vs. Cross-Pinned

Telephone-type and twisted-pair cables are frequently “cross-pinned”; that is, the individual wires inside the cable connect the pins in one connector to differently numbered pins in the other connector. Do *not* use cross-pinned cables if you can help it. Instead, each cable should be

pinned “straight-through”: The individual wires inside the cable should connect the pins in one connector to the same-numbered pins in the other connector.

If you don’t know whether a particular cable that you would like to use is straight-through or not, you can check its pinning relatively easily. Take both ends of the cable and hold them up next to each other with the connectors facing the same way, as shown in the upper two illustrations below:

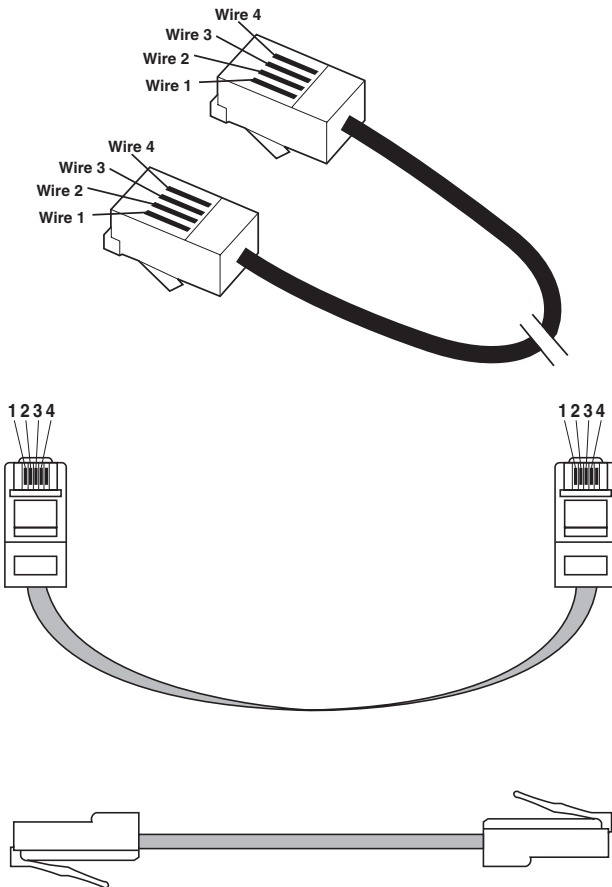

Look at the individual wires showing in the connectors: If they “read” the same way in both connectors—if, for example, the leftmost wires are both red and in the first slot, the second-from-left wires are both green and in the second slot, etc.—the cable is pinned straight-through. If the color order is backward or scrambled, or if slot assignments are different for any wires, the cable is not straight-through.

If you absolutely *must* use cross-pinned cable, you will have to order or build specially pinned modular adapters. Call your supplier for technical support.

Here are the part numbers for the cables you might need. All three cables are four-wire and are pinned straight-through. When you order, specify the length you need.

- Flat satin cable is EL04MS.
- UTP PVC cable is EYN712MS-MM.
- UTP plenum-rated cable is EYN714MS-MM.

3.1.1.C Connecting the Modular Cables

Start with the system administrator’s PC. Run the appropriate cabling from the RJ-12 jack on the PC’s modular adapter to input port 1 on the Multipoint Spooler VII. Once this is done, go to each of the other PCs and run cable from their modular adapters to the MPS-VII’s other input ports in the same way.

Once cable is connected to its modular adapter, the rear panel of a PC with a DB25 serial port might look like this:

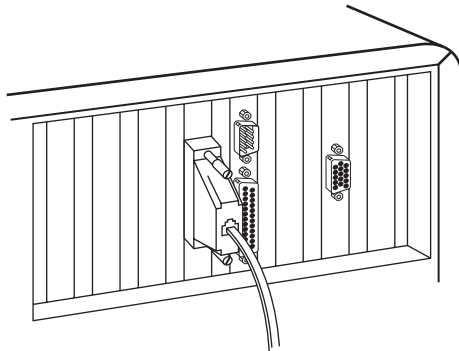

The rear panel of a PC with a DB9 serial port might look like this:

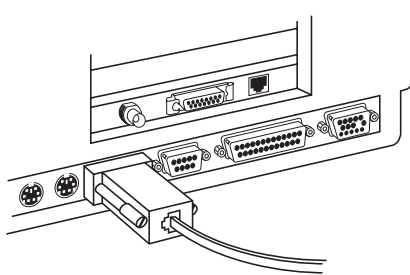

3.1.2 PARALLEL INSTALLATION

If a PC doesn't have a free serial port to which you can attach cable from the Multiport Spooler VII, but *does* have a free parallel port, there is still a way to connect that PC to the MPS-VII system:

1. Run parallel printer cable (EYN600) from the PC's parallel port to the parallel side of a Serial↔Parallel Converter III (PI115A).
2. Attach a modular adapter (PI725A) to the Converter's DB25 female serial port.
3. Choose cabling using Section 3.1.1.B as a guide; plug one end of the cable into the modular adapter, and plug the other end into one of the MPS-VII's serial input ports.
4. Plug the Serial↔Parallel Converter III's power supply into a working outlet.

Once you configure and begin operating your system, the Serial↔Parallel Converter III will translate the PC's parallel output into serial data that the MPS-VII can accept.

NOTES

- 1) The Serial↔Parallel Converter III's serial output port must be set to operate as a "DTE" (see the Converter's manual).
- 2) The data rates you set on the MPS-VII's input port (see Section 4.2, step 11) and on the Serial↔Parallel Converter III's serial port (see the Converter's manual) must match. (Be aware that the maximum serial data rate of the Serial↔Parallel Converter III is 38.4 Kbps.)
- 3) You can build your own modular adapter for the Converter's DB25 female serial port, but be sure to follow the pinning shown for the PI725A adapter in Appendix A.

3.2 Connecting Printers to the Multiport Spooler VII

The Multiport Spooler VII has four output ports, two parallel and two serial. One printer can be connected to each of these ports.

3.2.1 PARALLEL-PRINTER INSTALLATION

The Multiport Spooler VII's parallel ports are DB25 connectors, just like the parallel port(s) on a PC. To connect a parallel printer to one of these ports, use a standard parallel printer cable with a DB25 male connector on one end and a 36-position Centronics® connector on the other. (Our product code for this cable is EYN600; we offer it in lengths up to 20 feet [6.1 m], the maximum distance that parallel signals can be passed by this type of cable). Plug the DB25 male connector into the MPS-VII, then attach the Centronics connector to the printer, as shown below:

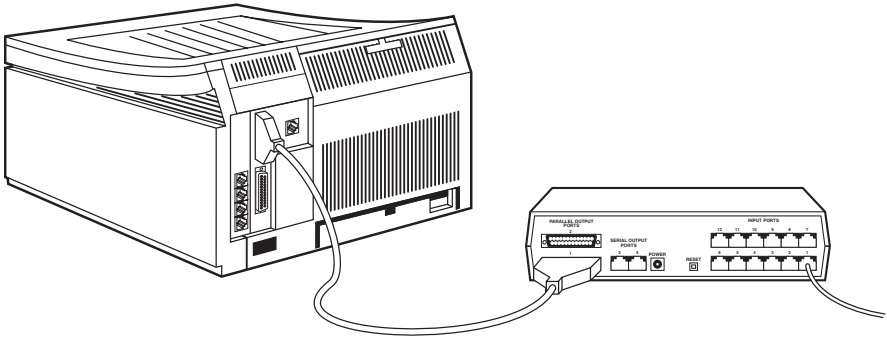

Notice the straight-through cable connected to port 1 of the Multiport Spooler VII in the above illustration; this cable runs to the modular adapter on the system administrator's PC.

3.2.2 SERIAL-PRINTER INSTALLATION

The Multiport Spooler VII's serial output ports are “telephone-style” RJ-12 (six-wire RJ-11) female connectors, just like its input ports. Since there are many different types of serial printers and plotters, some of which have unique types of connectors or connector pinning, there is no “one-size-fits-all” modular adapter for connecting *any* printer or plotter to the MPS-VII. However, to connect *most* serial printers or plotters that have DB25 female input ports, including HP® and Epson® models, use this modular adapter (PI725A) that has a DB25 male connector:

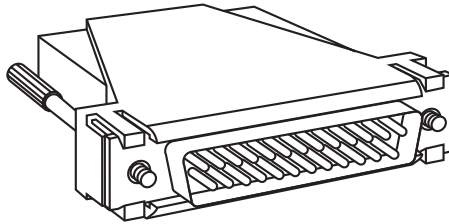

(As with the other modular adapters, you can build your own, but be sure to follow the pinning shown for the PI725A adapter in **Appendix B**. If this modular adapter will not work with your printer, call your supplier for technical support.)

Attach this adapter to the DB25 female serial port on your printer. Now choose cabling using **Section 3.1.1.B** as a guide; plug one end of the cable into the modular adapter, and plug the other end into one of the MPS-VII's serial output ports.

You must set the data rates of the Multiport Spooler VII's serial output port (see **Section 4.2, step 10**) and the printer's input port (see the printer's manual) to match.

3.2.3 CONNECTING A PARALLEL PRINTER TO A SERIAL OUTPUT

If you need to connect more than two parallel printers to the same Multipoint Spooler VII, you can connect parallel printers to the MPS-VII's serial outputs:

1. Run Centronics male-to-male cable (EQN380-MM) from a printer's input port to the parallel side of a Serial↔Parallel Converter III (PI115A).
2. Attach a modular adapter (PI725A) to the Converter's DB25 female serial port.
3. Choose cabling using **Section 3.1.1.B** as a guide; plug one end of the cable into the modular adapter, and plug the other end into one of the MPS-VII's serial output ports.
4. Plug the Serial↔Parallel Converter III's power supply into a working outlet.

Once you configure and begin operating your system, the Serial↔Parallel Converter III will translate the MPS-VII's serial output into parallel data that the printer can accept.

NOTES

- 1) The Serial÷Parallel Converter III's serial input port must be set to operate as a "DTE" (see the Converter's manual).
- 2) The data rates you set on the MPS-VII's output port (see Section 4.2, step 10) and on the Serial÷Parallel Converter III's serial port (see the Converter's manual) must match. (Be aware that the maximum serial data rate of the Serial÷Parallel Converter III is 38.4 Kbps.)
- 3) You can build your own modular adapter for the Converter's DB25 female serial port, but be sure to follow the pinning shown for the PI725A adapter in Appendix B.

3.2.4 CONNECTING A SERIAL PRINTER TO A PARALLEL OUTPUT

If you need to connect more than two serial printers to the same Multiport Spooler VII, you can connect serial printers to the MPS-VII's parallel outputs:

1. Run parallel printer cable (EYN600) from one of the MPS-VII's parallel ports to the parallel side of a Serial↔Parallel Converter III (PI115A).
2. Run standard fully-pinned RS-232 cable (ECN25C-MM) from the serial side of the Converter to the printer's input port. (This cable has DB25 male connectors on both ends and should work for most serial printers and plotters. If you find that this cable will not work with your printer, call your supplier for technical support.)
3. Plug the Serial↔Parallel Converter III's power supply into a working outlet.

Once you configure and begin operating your system, the Serial↔Parallel Converter III will translate the MPS-VII's parallel output into serial data that the printer can accept.

NOTES

- 1) The Serial↔Parallel Converter III's serial input port must be set to operate as a "DCE" (see the Converter's manual).
- 2) The data rates you set on the printer's port (see the printer's manual) and on the Serial↔Parallel Converter III's serial port (see the Converter's manual) must match. (Be aware that the maximum serial data rate of the Serial↔Parallel Converter III is 38.4 Kbps.)

3.3 Final Steps

Once you've installed all of the PCs and printers, take these final steps to finish your hardware installation:

1. Recheck all of the cable connections to make sure they are secure.
2. Plug in and turn on all of the attached printers, the system administrator's PC (the one connected to input port 1), and any Serial↔Parallel Converter IIIs that aren't already on.
3. Plug the Multiport Spooler VII's power supply into a working outlet.
4. The MPS-VII's front-panel LEDs will quickly flash on and off several times as the MPS-VII performs a diagnostic self-test. All of the LEDs should then go out except for the red Power LED. (If other LEDs besides the Power LED stay on, press the reset button on the MPS-VII's rear panel. All of the LEDs should flash and then—except for the Power LED—go out. If other LEDs still stay on, call your supplier for technical support.)

Your system is now ready for software installation.

4. Software Installation and Configuration

After you prepare the system's hardware, as described in the previous chapter, you must install the Multiport Spooler VII's software on each PC. This chapter will cover the following steps in this process:

1. Running the **SETUP** (install) program on the system administrator.
2. Running the **SETUP** program on the workstations.
3. Running the Print Test during the **SETUP** program on PCs connected to the Multiport Spooler VII through their parallel ports.

NOTES

1) You should make a copy of the included installation diskette, put the original away in a safe place, and use the copy for the software-installation process.

2) This chapter assumes that you are installing a single Multiport Spooler VII. The software configuration will be somewhat different if you are installing multiple MPS-VIIs in a daisychain. See Chapter 6.

3) This chapter also assumes that the workstations attached to the Multiport Spooler VII are running Windows. DOS-only PCs will run **INSTALL.EXE** from DOS, instead of **SETUP.EXE** from Windows, to install the software; see Appendix A. However, the system administrator's PC must be a Windows machine and must use **SETUP.EXE** to configure the system.

4.1 The Windows **SETUP** Program

You can do several things with the **SETUP.EXE** program. A few of its functions are available on all PCs on the system:

1. Copy the Multiport Spooler VII's software files from the installation disk to the PC's hard-disk drive.
2. Perform a print test for PCs connected to the Multiport Spooler VII through serial↔parallel converters.
3. Test cabling.

The other functions are available only on the system administrator's PC:

4. Name each printer and PC user.
5. Enable or disable banner pages.
6. Configure the Multiport Spooler VII.
7. Create a configuration file used to configure the other PCs on the system.

SETUP.EXE will run a little bit differently on a PC connected through its serial port than it will on a PC connected through its parallel port. This is because the parallel installation requires a print test to determine if the cabling is good and if the PC and the Multiport Spooler VII are communicating. **Sections 4.2** and **4.3** describe the elements common to both serial and parallel installation; **Section 4.4** describes the "print test detour" that occurs during parallel installation only.

4.2 System-Administrator Setup

Perform all necessary procedures with the system administrator's PC first:

1. Start Windows.
2. Insert the copy of the MPS-VII's software diskette into the 3.5" diskette drive.
3. Select the Run option under the File menu in the Windows Program Manager, type A:\SETUP in the Command Line field, and click on the OK button. After a few moments, this screen appears:

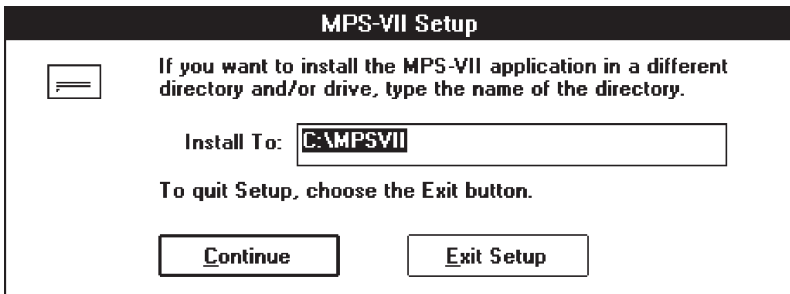

- Specify the hard-disk directory into which the Multiport Spooler VII files will be copied. Click on the **Continue** button to accept the default directory (which will be automatically created by the program), or enter another directory name and then click on **Continue**.
- After the files have been copied, you will be asked whether this is an “Administrator” installation or a “Workstation” installation. Select “Administrator.” At this point the program will let you know that the files have been successfully copied. Click on **OK** and the system will begin to search for the Multiport Spooler VII connection. Wait until this process is completed.
- If the system administrator’s PC is connected to the MPS-VII through the PC’s parallel port and a Serial↔Parallel Converter III, you should see this screen:

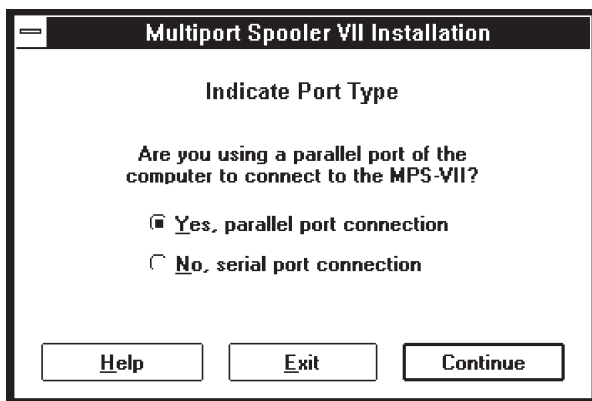

You can click on **Continue** to trigger the print test that should be performed under these conditions (see **Section 4.4**); after the print test ends, the setup resumes with the next step.

If you aren’t using the PC’s parallel port, but you get this screen anyway, click on the “No, serial port connection” radio button. A “No Connection” screen will appear stating that the program could not find the Multiport Spooler VII. This probably means that a cable or adapter is loose somewhere between the PC and the MPS-VII. Recheck all your connections; if you can’t find anything wrong, click on the **Help** button for on-line help or see **Section 7.1** of this manual.

7. Depending on how the Windows environment is currently configured on the system administrator's PC, you might see one, both, or neither of the following screens:

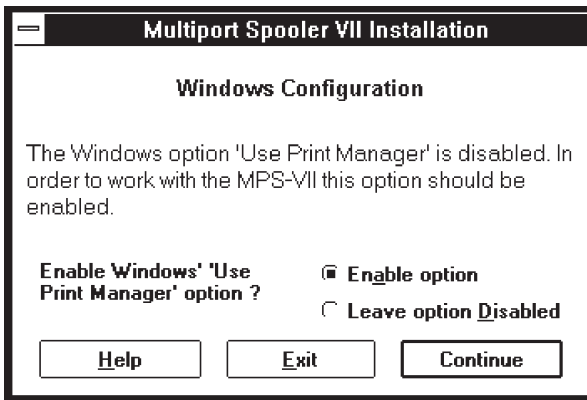
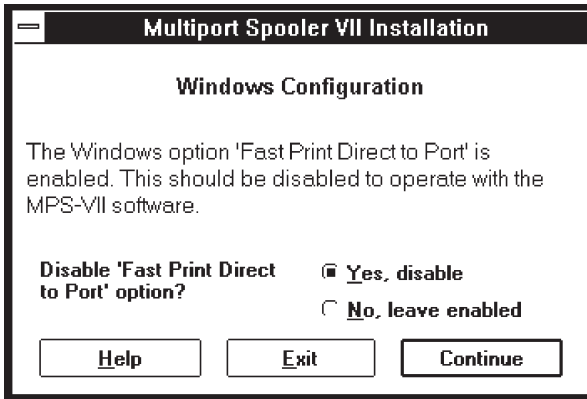

In order for the Multiport Spooler VII to function properly, “Fast Printing Direct to Port” should be disabled and Print Manager should be enabled. If you do not allow the Multiport Spooler VII **SETUP** program to make these changes for you, you will have to make them yourself after running **SETUP**. (If Windows is configured correctly on the system administrator's PC, you will not see these screens.)

8. The following screen will now appear, asking permission to make changes to the **AUTOEXEC.BAT** file of the system administrator's PC:

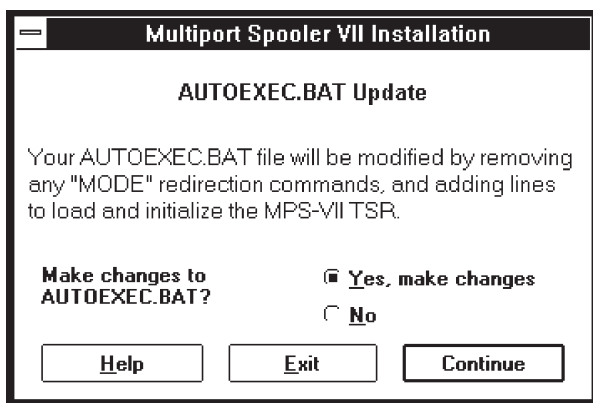

In most cases you should make sure that the “Yes” radio button is enabled and then click on **Continue** so that these changes are automatically made. If, for some reason, you do not want the changes automatically made to your **AUTOEXEC.BAT** file, select the “No” radio button; later, you will have to manually enter the following lines into your **AUTOEXEC.BAT** file:

```
C : \MPSVII\REDIR
SET MPSVII=C : \MPSVII\
C : \MPSVII\MPSVII -I
```

9. Next, the system-setup screens appear. These are a series of several screens with which you can customize the system. An introductory screen appears; click on **Start** and this screen will appear:

MPS-VII Black Box

How many MPS-VII units are you installing?

Single MPS-VII Installation

Two or more cascaded MPS-VII units

Help Exit <Back Continue>

This screen requires you to tell the system whether you are setting up one Multiport Spooler VII or daisy chaining several together. (The daisy chain installation is discussed in **Chapter 6**.) For a single MPS-VII installation, make sure that the proper radio button is selected and click on **Continue**. You will move to the initialization screen:

MPS-VII Black Box

MPS-VII Initialization

Skip Initialization

Initialization Options

Current Configuration Reset to Factory Defaults

Select [Continue] to reset configuration parameters

Help Exit <Back Continue>

Make sure that “Reset to Factory Defaults” is selected, and then click on **Continue**.

10. The system will again connect with the Multiport Spooler VII for a moment, initializing each port, and then move on to the Set Up Printers screen:

The screenshot shows a software window titled "MPS-VII" with a "Black Box" logo in the top right corner. The main area is titled "Set Up Printers". It features a "Select Port" section with "<<Prev" and "Next>>" buttons, and "Output 1 (Par)". Below this, there are two configuration fields: "Assign Name to Printer:" with an empty text input box, and "End of Job Separator" with a dropdown menu currently set to "Form Feed Char". At the bottom of the window, there are four buttons: "Help", "Exit", "<Back", and "Continue>".

To give each printer a specific name, click your cursor into the “Assign Name to Printer:” field and enter the name. You also need to choose an end-of-job separator. This is a command that is sent to the printer at the end of each job to reset the printer. The default is “Form Feed Character,” which is appropriate for most printers. Another choice is “HP PCL Reset,” which is appropriate for most HP printers. The “Custom Sequence” selection is for any advanced users who want to send a special reset code to the printer: A small box will appear which allows you to enter a custom end-of-job separator.

Use the **Prev** and **Next** buttons to move back and forth among the MPS-VII’s output ports. The screen above shows a parallel port selected. When you select a serial port, an additional “Baud Rate” field appears. If you have connected a serial printer to the serial port, enter the printer’s data rate in this field. If you have connected a parallel printer to the serial port through a Serial↔Parallel Converter III, make sure the data rate you enter matches the data rate set on the Converter. Click on **Continue** when you’ve finished setting up each printer.

11. Now the Set Up Users screen will appear:

The screenshot shows the 'Set Up Users' configuration screen for MPS-VII. At the top left, it says 'MPS-VII' and 'Set Up Users'. In the top right corner, there is a 'Black Box' logo. The screen is divided into several sections: 'Select Port' with '<<Prev' and 'Next>>' buttons; 'Input Port 1' label; 'Assign Name to User' with an empty text box; 'Handshaking' with a radio button selected for 'DTR/DSR'; 'End of Job Timeout' with a spinner set to '20' and 'Seconds' label; 'Baud Rate' with a spinner set to '19200' and 'Baud' label. At the bottom, there are buttons for 'Help', 'Exit', '<Back', and 'Continue>'.

At this screen you can configure all of the Multipoint Spooler VII's input ports, starting with input port 1 (the port to which the system administrator's PC is connected). You can set four parameters for each port:

- a. **Assign Name to User:** Enter the user's name.
- b. **End of Job Timeout:** You can extend the timeout period for users that print graphics-intensive documents, but for most users 20 seconds is more than enough to safely handle most text and graphics documents.
- c. **Baud Rate:** The default data rate is 19.2K "Baud" (19,200 bps). You can increase this to a maximum of 115.2K "Baud" (115,200 bps).
- d. **Handshaking:** For the system administrator's PC, the flow control (handshaking) method will be "grayed out," because it is already communicating. This option will be selectable for the user PCs, however. For virtually any PC application, the flow control should be "DTR/DSR." "Robust Xon" (robust X-ON/X-OFF) is used in some mainframe applications. If you are unsure, your best bet is "DTR/DSR."

Once you have completed the configuration of input port 1, click on **Next** to set up each of the other user ports, as needed. After you've configured all of the ports, click on **Continue**.

12. The Print Direction screen is next:

In most cases, all of your workstations will be PCs that can select printers with the MPS-VII's TSR for DOS and Windows. For workstations that fit this description, make sure the "PC running DOS or Windows" radio button is enabled, then click on **Continue**.

However, if you have connected any computers to the Multiport Spooler VII that don't run DOS or Windows (mainframes or Apple® computers, for example), their users will be unable to select printers. Therefore, you must assign a printer for all of their print jobs at this screen. Click on the "Non DOS machine" radio button; a pull-down printer menu will appear. Select the default printer, then click on **Continue**.

13. The Define Banner Pages screen is next:

MPS-VII
Define Banner Pages

Select Port <<Prev Next>> Input Port 1

Title Banner Page End of Job Banner Page

Use Title Banner Use End Banner

Help Exit <Back Continue>

Banner pages print out either before (as a “Title Banner”) or after (as an “End of Job Banner”) a print job. Banner pages are useful for dividing print jobs as they pile up in the printer tray on very busy printers. You can enter up to 16 characters of text for each banner page if you elect to enable them. As before, click on **Next** to configure the other user ports and, when finished, click on **Continue**.

14. The final screen in the configuration series asks you to give a target destination for the configuration file:

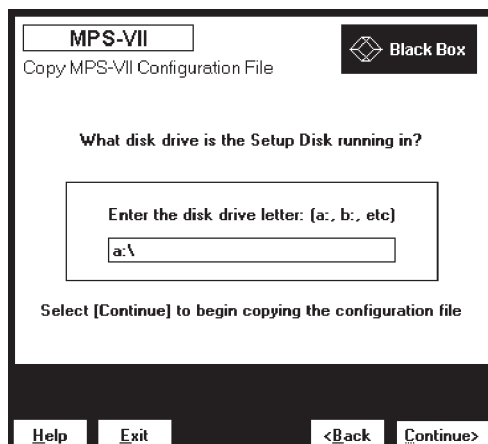

At this point the program needs to copy a configuration file back to your original installation diskette. This file, **MPSVIIA.INI**, will carry the new configuration you have just completed to each of the user PCs. To complete this screen, simply enter the letter of the disk drive that the installation diskette is currently running from, and then click on **Continue**. The configuration file will be copied back to the diskette, and you will then use that diskette to configure the rest of your PCs.

After you click on **Exit** to exit the installation program, you must reboot your PC to make the changes in the **AUTOEXEC.BAT** file (see **step 8**) current in your PC's memory.

You have now finished installing software on and configuring the system administrator's PC. Now use the same disk to perform this task on each workstation PC.

4.3 Windows Workstation Setup

Before you can run the Multipoint Spooler VII's **SETUP.EXE** program on the user workstations, you must have first run **SETUP** on the system administrator's PC (the PC connected to input port number 1). See the previous section.

To install software on and configure a user's workstation PC, follow these steps:

1. Insert the installation diskette (onto which you copied **MPSVIIA.INI** during the system-administrator installation) into the PC's 3.5" diskette drive.
2. Select the Run option under the File menu in the Windows Program Manager, type **A:\SETUP** in the Command Line field, and click on the button. Select the directory you want to contain the MPS-VII's software files, just as you did during step 4 of the administrator installation.
3. After the files have been copied to the workstation PC's hard drive, a screen will appear that asks you whether you are installing an "Administrator" or a "Workstation," just as in step 5 of the administrator installation. Select "Workstation."
4. At this point the program will let you know that the files have been successfully copied to the hard drive. Click on and the system will begin to search for the Multipoint Spooler VII connection. Wait while this process is completed.

If the workstation PC is connected to the MPS-VII through the PC's parallel port and a Serial↔Parallel Converter III, you should see the screen from step 6 of the administrator installation. You can click on Continue to trigger the print test that should be performed under these conditions (see **Section 4.4**); after the print test ends, the setup resumes with the next step.

If you aren't using the PC's parallel port, but you get this screen anyway, click on the "No, serial port connection" radio button. A "No Connection" message will appear stating that the program could not find the Multipoint Spooler VII. This probably means that a cable or adapter is loose somewhere between the PC and the MPS-VII. Recheck all your connections; if you can't find anything wrong, click on the Help button for on-line help or see **Section 7.1** of this manual.

5. After the connection is verified, you will see the screen which requests permission to change the **AUTOEXEC.BAT** file, just as in step 8 of the administrator installation. (You might also see the “Disable Fast Printing Direct to Port” screen and/or the “Use Print Manager” screen from step 7 of the administrator installation.) The Multiport Spooler VII will not operate properly without these changes being made, so you should select “Yes.”

At this point the workstation setup is complete. You should exit Windows and reboot each machine after running the setup program to make the changes in the **AUTOEXEC.BAT** file current in the memory of each PC.

To begin printing from your applications on all of the PCs, you need to make a few minor adjustments in Windows. These are described in the next chapter.

4.4 The Parallel-Port Print Test

When a PC is connected to the Multiport Spooler VII through the PC's parallel port and a Serial↔Parallel Converter III, the **SETUP.EXE** program is unable to directly verify that the connection is good. In order to verify that you have a good connection, **SETUP** gives you the option of sending a print test to a printer connected to the Multiport Spooler VII. This occurs right after the program copies all of the MPS-VII's software files onto the PC's hard drive.

NOTE

The printer to which you send the print test must be able to print ASCII characters.

1. After the files are copied onto the PC's hard drive, the program will briefly try to find the Multiport Spooler VII and will fail. You will see the screen shown in step 6 of the administrator installation. Select "Yes, parallel port connection" and click on **Continue**. This screen will appear:

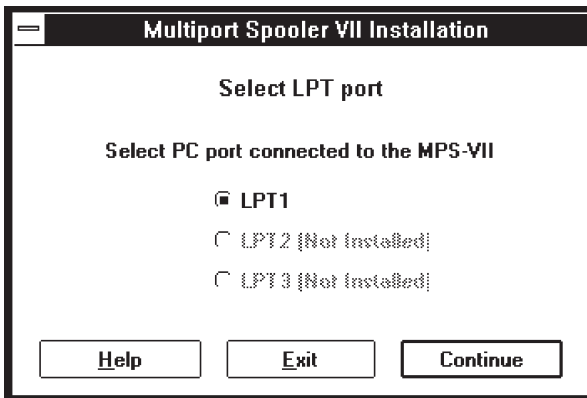

2. Select the parallel port on the PC to which the MPS-VII is connected, and then click on **Continue**. This screen will appear:

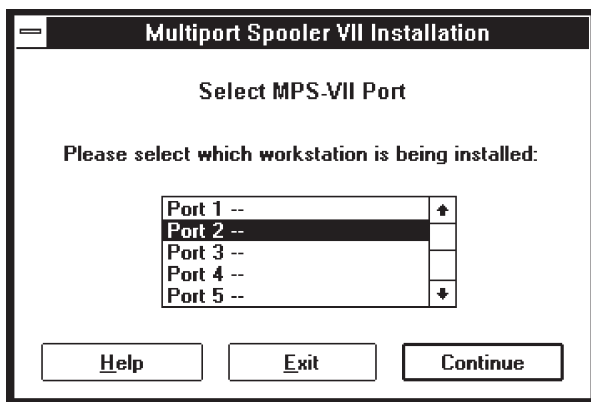

3. Select the port on the MPS-VII to which the PC is connected. (If you lose track of which port you are working on, trace the cable from the PC to the MPS-VII's rear panel.) Click on **Continue**.
4. You will be warned that you must have a printer on the system which can print ASCII characters. If you *do not*, click on "No" and **Continue**, and the print test will be aborted. If you *do*, click on "Yes" and **Continue**, and the printer-selection screen will appear:

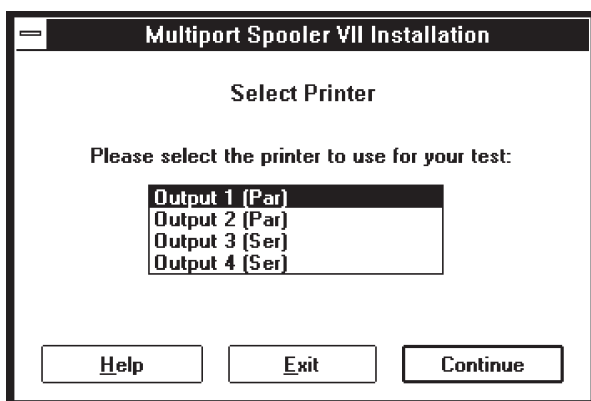

5. Select one of the connected printers. Make sure the printer is on line. Click on **Continue**; a “Test sent” screen will appear, and the print test will be sent. Check the page to make sure it prints out correctly. It should look something like this:

```
Multiport Spooler VII Test Page
Time: 8:09:46 AM
Date: 7/21/94
!"#$%&'()*+,-./0123456789:;<=>?@ABCDEFGHIJKLMN OPQRSTUVWXYZ[\]^`
!"#$%&'()*+,-./0123456789:;<=>?@ABCDEFGHIJKLMN OPQRSTUVWXYZ[\]^`
!"#$%&'()*+,-./0123456789:;<=>?@ABCDEFGHIJKLMN OPQRSTUVWXYZ[\]^`
!"#$%&'()*+,-./0123456789:;<=>?@ABCDEFGHIJKLMN OPQRSTUVWXYZ[\]^`
!"#$%&'()*+,-./0123456789:;<=>?@ABCDEFGHIJKLMN OPQRSTUVWXYZ[\]^`
!"#$%&'()*+,-./0123456789:;<=>?@ABCDEFGHIJKLMN OPQRSTUVWXYZ[\]^`
<End of Test>
```

6. If the page prints out without garbage, click on **OK**. **SETUP** will return to the regular configuration procedure; complete this as described in **Section 4.2** or **4.3**, whichever is appropriate.
If, on the other hand, garbage prints or you get nothing at all, follow the instructions in steps 7 through 13.
7. Make sure the Multiport Spooler VII's Power LED is lit.
8. Make sure that the printer you've chosen can print ASCII, is powered up and on line, and is securely connected to the proper port on the Multiport Spooler VII. Reset the printer.
9. Press the reset button on the back of the Multiport Spooler VII. A test page should print out showing the current data-rate setting of each of the MPS-VII's ports. Make a note of the data-rate setting for the port to which the PC you are troubleshooting is connected.
10. Turn off the PC. Unplug the Serial↔Parallel Converter III. Look at the Converter's controls and consult the Converter's manual to determine the Converter's current data-rate setting.

11. If the Converter's data rate doesn't match the data rate of the connected MPS-VII port, follow the directions in the Converter's manual and reset the Converter's data rate to match that of the port.
12. Make sure cable is securely connected to the proper parallel port on the PC. Make sure that cables are securely connected to the Converter and to the proper input port on the MPS-VII.
12. Plug the Converter back in. Turn the PC back on.
13. Retry the print test.

If you continue to have difficulty, see **Chapter 7**. If the troubleshooting sections in that chapter don't help, call your supplier for technical support (see **Section 7.6**).

5. Operation

This chapter explains how to use Windows menus and the Multipoint Spooler VII's Control software to control Spooler operation, including:

1. Assigning printers and printer drivers to the PC's virtual ports, which the Spooler uses.
2. Printing to shared and local printers from Windows applications.
3. Performing diagnostics on the Spooler system and changing some aspects of the Spooler's configuration.

5.1 Functions of the Control Program

Each user can do several very important things with the Multipoint Spooler VII's Control program:

1. Configure printers and printer drivers.
2. Test the cable connection from their PC to the Multipoint Spooler VII.
3. Send a print test to any shared printer on the system.
4. Change the PC port or MPS-VII port they are connected to.
(The program will automatically reconnect using the new port.)
5. Set their data rate.
6. Set the length of their end-of-job timeout.

5.2 Sharing a Single Printer

Even if you are sharing more than one printer, the simplest way to prepare for operation is to set up the system for a single shared printer. After you have successfully done this, it will be easy for you to add any other printers into the system.

Make sure you have rebooted each PC after running the Multiport Spooler VII's Setup program, to ensure that the new configuration is current in each PC's memory. The following printer-setup instructions are the same for administrator and workstation PCs:

1. At the Windows Program Manager, go to the Multiport Spooler VII program group and select Multiport Spooler VII Control. This screen will appear:

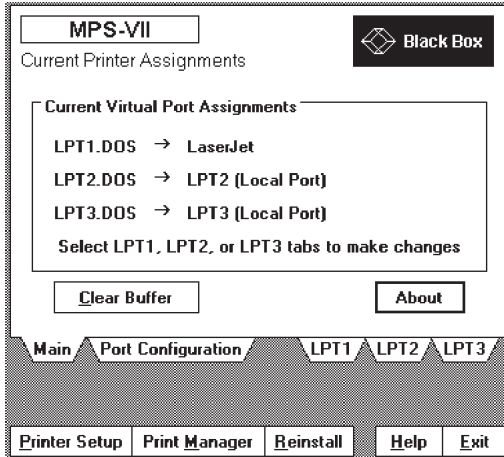

Windows allows you to assign printers to “virtual ports.” This means that you can list printers on LPT2 and LPT3 as well as LPT1, even if you do not have the hardware for the LPT2 and LPT3 ports installed on your computer. Examples of virtual ports are LPT1.DOS, LPT2.DOS, and LPT3.DOS. Print jobs can be redirected from these virtual ports to external devices. The MPS-VII and other printer-sharing devices take advantage of this ability to make it possible for you to share multiple printers. Since we are only configuring for one shared printer at the moment, we will just concentrate on LPT1.

2. Click on the tab for LPT1. This screen will appear:

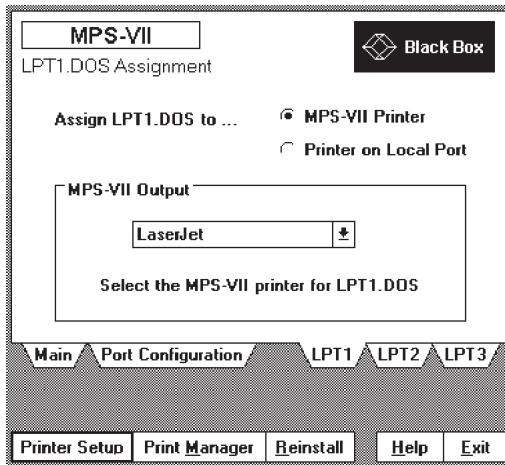

This shows that the Windows LPT1 virtual port has been set to automatically print to the printer connected to output port 1 (which in this case has been named “LaserJet”). You can use this screen’s pulldown box to change this selection to any port with a printer connected to it. However, for the purpose of our example, we’ll use LaserJet. The MPS-VII Printer button should be selected. The only thing left to do now is make sure that the correct printer driver is connected to LPT1.DOS in the Printer Setup window under the Windows Control Panel. In the screen shown above, click on Printer Setup and you will immediately go to that Printer Setup window:

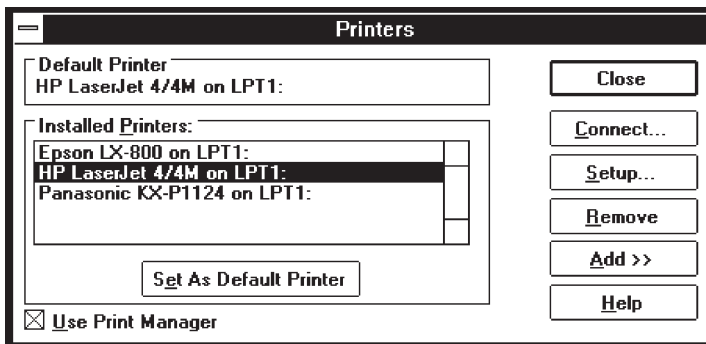

- Highlight the appropriate printer driver (in this case, “HP LaserJet 4/4M on LPT1”) and click on **Connect**. This screen will appear:

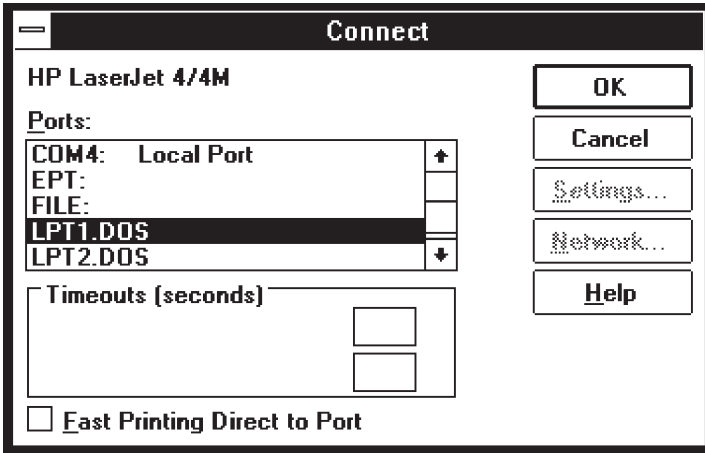

- In the Ports field, use the scroll bar to scroll down to the port selections that end in “.DOS” or “.OS2.” Select **LPT1.DOS** or **LPT1.OS2**, whichever is available. Click on **OK**. You should now see the HP printer driver connected to the LPT1.DOS virtual port:

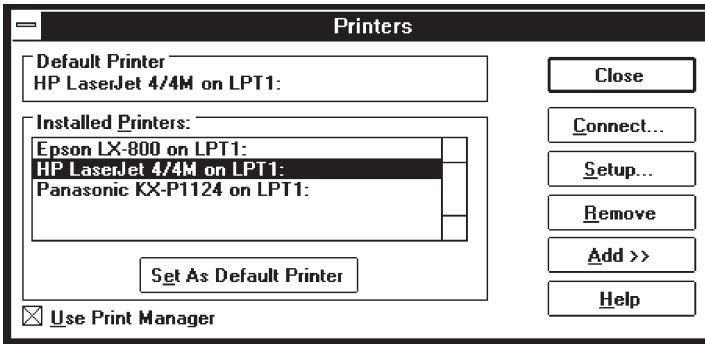

- Select **Close**. At this point, you are correctly configured to print to the printer on output port 1 called “LaserJet.”

6. Configure each workstation PC in the same manner.
7. **IMPORTANT:** In each Windows application that you'll be printing from, make sure that your target printer is the printer connected to LPT1.DOS.

Once this configuration process is complete, all of your users will be set up to print to the printer listed on the LPT1 tab, from any Windows or DOS application.

5.3 Printing from a Windows Application

Once you have configured the system as described above, printing to the printer is just a matter of selecting the correct printer driver in your Windows applications. To print to the Multiport Spooler VII's printer from any Windows application, take these steps:

1. From any Windows application, select Printer Setup under the File menu. A screen similar to this should appear:

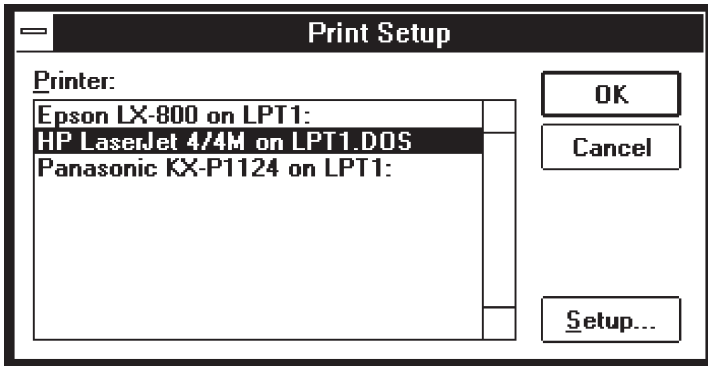

2. Make sure that the printer driver for the MPS-VII printer (in this case "HP LaserJet 4/4m") is selected and assigned to LPT1.DOS.
3. Print as usual. Any print jobs will automatically be directed to the MPS-VII's printer.

5.4 Sharing Multiple Printers

5.4.1 MODIFICATIONS IN THE MULTIPOINT SPOOLER VII'S CONTROL PROGRAM

Configure any additional printers in the same way you configured the first printer, but assign them to LPT2.DOS or LPT3.DOS. Proceed as follows:

1. In the Multipoint Spooler VII's Control program, go to the LPT2 tab. Make sure MPS-VII Printer is selected. Use the pulldown box to find another printer you want to share and select it (in this case we'll select the printer named "Epson LX-800"):

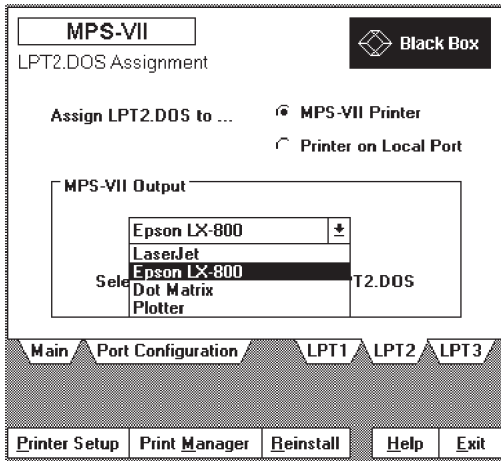

2. Then select Printer Setup and, as before, assign your additional printer to LPT2.DOS:

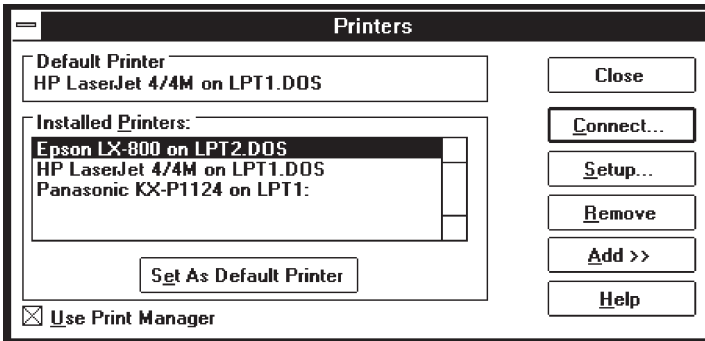

3. Select the **Main** tab in the MPS-VII's Control program. The configuration should now look like this:

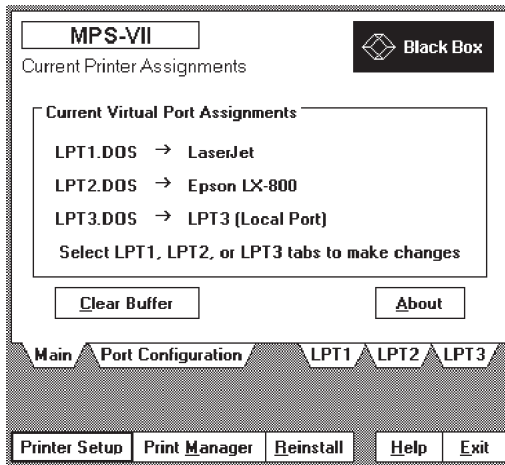

The LaserJet® is now directed to LPT1.DOS and the Epson LX-800 printer is directed to LPT2.DOS. (The Panasonic® KX-P1124 printer shown in the Printer Setup window is a local printer both physically attached and logically assigned to the PC's LPT1 port. For the MPS-VII's TSR to handle print jobs for the Panasonic, you would have to logically reassign the Panasonic to LPT3.DOS—see **Section 5.5**.)

To add a third printer to the system, simply click on the **LPT3** tab and perform the same operation, this time assigning the printer to LPT3.DOS in Printer Setup.

5.4.2 CHOOSING PRINTERS IN YOUR WINDOWS APPLICATIONS

You can now select printers merely by selecting the correct printer driver in your application software. Using the example above, if you wanted to print to the LaserJet printer, you would take these steps:

1. Open the document you wish to print. Go to the screen you would normally use to select a printer driver (in most applications it is located under the **File** menu and is called Target Printer or Printer Setup). A "list screen" will appear:

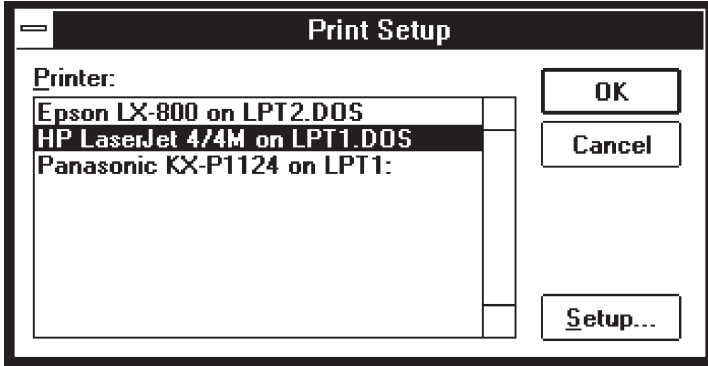

2. Simply select the printer driver for the printer you wish to print to—in this case, “HP LaserJet 4/4M on LPT1.DOS”—and select **K**.
3. Print as usual.

If you wanted to switch the print job to the Epson LX-800, you would take the same steps, but would select “Epson LX-800 on LPT2.DOS” at step 2. The TSR would automatically route your print job to the correct printer. You never have to leave your applications to select printers.

NOTE

If this function does not work for you, it probably means that you do not have LPT1.DOS, LPT2.DOS, or LPT3.DOS configured properly, or that you did not reboot your computer after the SETUP program was installed on your PC.

Keep this simple correspondence in mind when configuring the Multiport Spooler VII to handle multiple printers:

*Make sure the printer listed in Multiport Spooler VII Control under the **LPT1** tab is assigned to LPT1.DOS in the Windows Printer Setup.*

*Make sure the printer listed in Multiport Spooler VII Control under the **LPT2** tab is assigned to LPT2.DOS in the Windows Printer Setup.*

*Make sure the printer listed in Multiport Spooler VII Control under the **LPT3** tab is assigned to LPT3.DOS in the Windows Printer Setup.*

5.4.3 SHARING MORE THAN THREE PRINTERS

If you have four printers connected to the Multiport Spooler VII, the MPS-VII's Control program will not be able to list all of them as being active at the same time. This is because there are only three virtual ports available in Windows: LPT1.DOS, LPT2.DOS, and LPT3.DOS.

The easiest method of selecting the fourth printer will be to connect its printer driver to LPT3.DOS (so you will actually have two printers connected to LPT3.DOS in Printer Setup). When you need to print to this printer, you will have to leave your application (press **[ALT][TAB]**) and go to the MPS-VII's Control program. Then click on the **LPT3** tab and select the printer you want; it will be the other printer whose driver is assigned to LPT3.DOS.

5.5 Printing to a Local Printer Attached Directly to Your PC

Users sometimes need not only to be connected to one or more shared printers through the Multiport Spooler VII, but also to use a non-shared local printer connected directly to their PC. The MPS-VII's TSR supports this type of arrangement.

Continuing the same example we've been using throughout this chapter, let's say that in addition to the LaserJet and Epson printers connected to parallel ports on the Multiport Spooler VII, you have an HP DeskJet® you want to connect to your PC for your own personal use, not to be shared. This is defined as a "local printer." In order for the MPS-VII's TSR to handle directing jobs to that printer as well as the other two, you would have to take these steps:

1. Connect the DeskJet to the PC. Let's assume you use a standard cable to connect it to the PC and you connect it to the only parallel port on the PC, which would be LPT1.
2. You would then go into the Multiport Spooler VII's Control program and click on the **LPT3** tab.
3. Select the **Printer on Local Port** radio button, so that it goes dark instead of the **MPS-VII Printer** button.

- Use the pulldown bar to tell the MPS-VII's Control program which PC port you have physically (hardware) attached the printer to. In this case select LPT1:

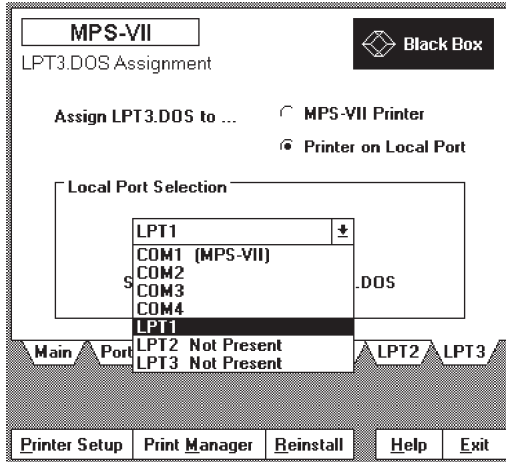

This redirects the LPT3.DOS virtual-port assignment to the hardware port LPT1.

- Go to Printer Setup and, as before, connect your printer driver to the appropriate virtual port in Windows—this time LPT3.DOS:

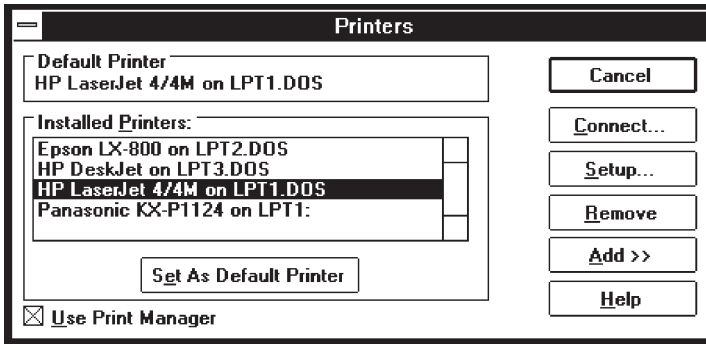

MULTIPOINT SPOOLER VII

Remember: Whatever device is listed under the **LPT3** tab in the MPS-VII's Control program must have its printer driver assigned to LPT3.DOS in the Windows Printer Setup.

As you can see, the HP DeskJet is now connected to LPT3.DOS; the Epson LX800 is connected to LPT2.DOS; and the HP LaserJet 4 is connected to LPT1.DOS as before.

The screen for the **Main** tab in the MPS-VII's Control program should now look like this:

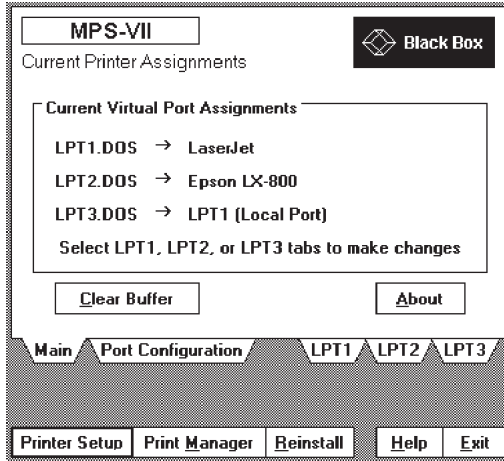

This screen shows the current virtual-port configuration:

- Virtual port LPT1.DOS is directed to the LaserJet attached to the Multiport Spooler VII.
- Virtual port LPT2.DOS is directed to the Epson LX800 attached to the Multiport Spooler VII.
- Virtual port LPT3.DOS is directed to a non-shared printer attached to the PC's LPT1 port.

You can now select any one of these printers merely by selecting the correct printer driver in any Windows application software—without ever leaving the application!

5.6 Diagnostic and Maintenance Functions of the Control Program

The Multiport Spooler VII's Control program has been designed to give the user maximum flexibility in print-job control, and also maximum assurance that the connection from the PC to the MPS-VII is good. Bad cabling is generally the problem when printer-sharing devices fail, and the MPS-VII's Control program addresses this problem by providing exhaustive cable diagnostics. To look at these functions, enter the Control program and select the Port Configuration tab. This screen should appear:

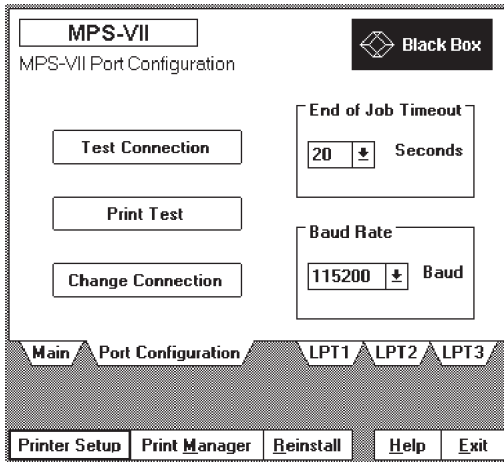

From this screen, you can:

- Test your cable connection,
- Perform a print test,
- Change the PC port or MPS-VII port to which you are assigned,
- Lengthen or shorten the end-of-job timeout period for your PC, or
- Change the data rate of your MPS-VII communication.

5.6.1 TO TEST YOUR CABLE CONNECTION

Take these steps:

1. Click on **Test Connection**. After a moment a screen similar to this should appear:

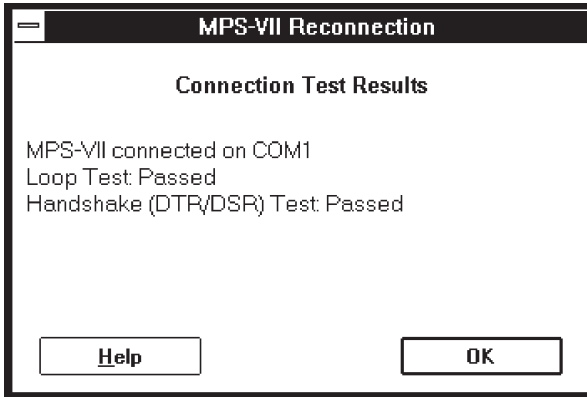

2. Click on **OK**, and you will return to the Port Configuration screen.
3. If you see a message such as

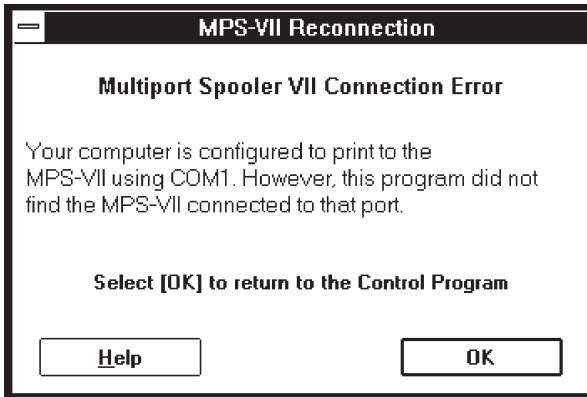

then your cable connection from the PC to the MPS-VII has failed. You can click on **Help** or refer to the "Troubleshooting" chapter for easy steps to determine what the problem may be, and suitable corrective action.

5.6.2 TO EXECUTE A PRINT TEST

At any time, you can execute a print test to A) determine if the connection between your PC and the Multiport Spooler VII is good (especially in parallel installations), and B) verify that a particular printer is on line and ready.

1. Click on **Print Test**. This screen will appear:

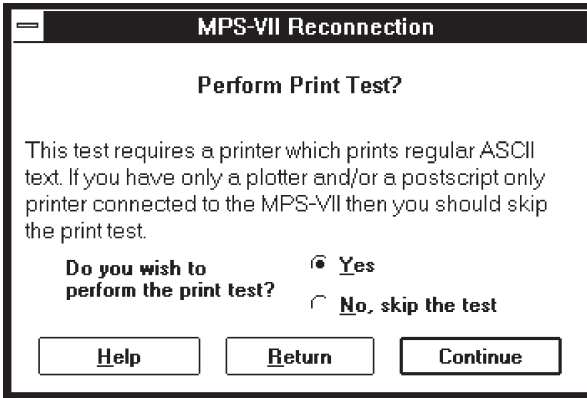

2. Select **Yes**, then **Continue**.
3. You will now be asked to choose which printer will print the print test:

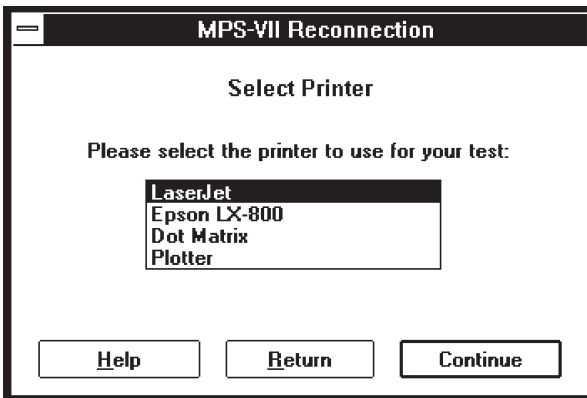

Select the name of the printer to which you would like to send the print test. The print test will be sent when you click on **Continue**.

4. If the print test fails, check **Section 7.1** or click on **Help** for on-line help that includes possible corrective actions.

5.6.3 TO CHANGE THE PC PORT OR THE MPS-VII PORT

It is important for the Multipoint Spooler VII software on your PC to know which MPS-VII port you are connected to, as well as which PC port you are using. If there is ever a reason for you to change the PC port or MPS-VII port, make the cabling change first. Then select **Change Connection**. The system will briefly reconnect to the Multipoint Spooler VII; the change will be detected and saved in the system.

5.6.4 TO CHANGE THE TIMEOUT PERIOD FOR YOUR PC

Simply use the “End of Job Timeout” pulldown box to select the timeout value that you desire. The change will immediately be made in the MPS-VII’s firmware.

5.6.5 TO CHANGE THE DATA RATE

Simply use the “Baud Rate” pulldown box to select the data rate (“baud rate”) that you would like the PC and the MPS-VII to use for communicating with each other.

CAUTION!

If the PC is connected to the MPS-VII through the PC’s parallel port and a Serial-Parallel Converter III, you must change the data rate on the Converter whenever you change the data rate for your PC.

6. Daisy chaining

6.1 Installing the Cables

If you will be daisy chaining multiple Multiport Spooler VII units, please read **Chapters 3 and 4** first. Most of the procedure is the same for a single Multiport Spooler VII as it is for a daisy chain. This chapter will only deal with the differences encountered in the setup for a daisy chain.

“Daisy chaining” (also called “cascading”) Multiport Spooler VIIs is connecting more than one MPS-VII together so that data may pass between them. PCs connected to one daisy chained MPS-VII can print to any printer connected to any MPS-VII in the chain.

The cables you must run between daisy chained Multiport Spooler VIIs are not pinned “straight through” (Pin 1 to Pin 1, Pin 2 to Pin 2, etc.). Specially “cross-pinned” unshielded twisted-pair cable (product code EHN066) is required for these connections.

The MPS-VII’s system administrator’s PC must be connected to input port 1 of the *first* Multiport Spooler VII in the daisy chain. Attach all workstation PCs to the MPS-VII using the standard adapters and straight-through-pinned cables described in **Chapter 3**.

To daisy chain Multiport Spooler VIIs, take these steps, using EHN066 for all cable connections (refer to Figure 6-1 on the next page):

1. Connect input port 2 of the *first* MPS-VII (box number 1) to input port 1 of the *second* MPS-VII.
2. Connect input port 2 of the *second* MPS-VII to input port 1 of the *third* MPS-VII (if there is a third), and so on.
3. Connect input port 2 of the *last* MPS-VII in the chain to the last input port (either port 4, port 8, or port 12 depending on the MPS-VII model) of the *first* MPS-VII.

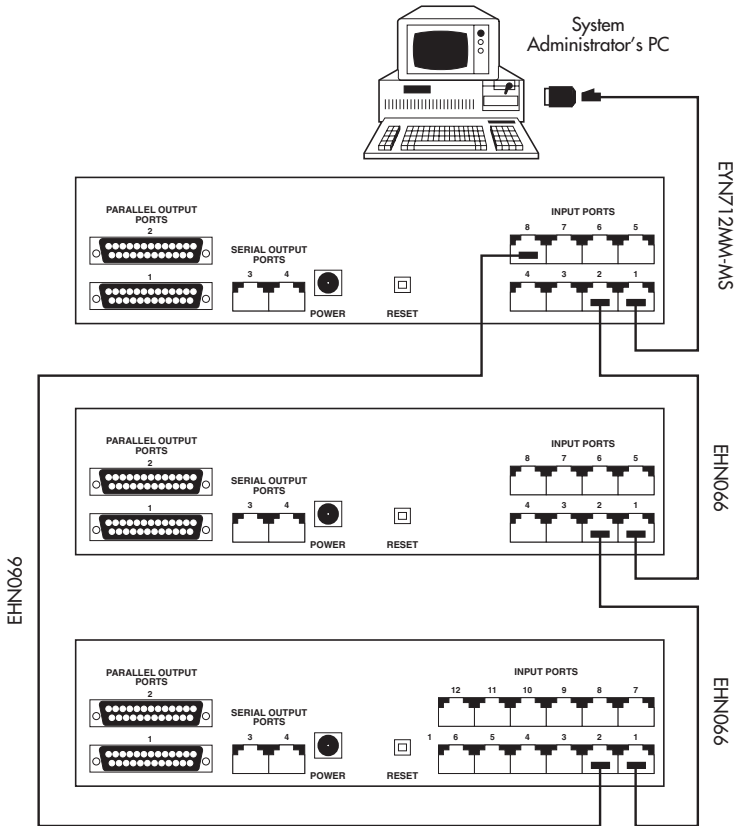

Figure 6-1. Cabling for a daisychain of three Multipoint Spooler VIIs.

6.2 System-Administrator Setup

CAUTION!

The system administrator on a daisy-chained Multiport Spooler VII system must be connected to the first MPS-VII through one of the serial ports on his or her PC. The setup program will not function properly if the system administrator is connected to the MPS-VII through a parallel port and a serial-to-parallel converter.

This section primarily outlines the differences in running setup for a daisychain as opposed to a single Multiport Spooler VII installation (refer to **Section 4.2**). Before you install the software, all of the daisychain cables should be in place and the system administrator's PC should be connected to input port 1 of the first unit in the daisychain.

1. Insert the software diskette into the diskette drive of the system administrator's PC. At the Windows Program Manager, select Run under the File menu. Type `A:\SETUP` and click on .
2. Either accept the default subdirectory or enter your own. Click on Continue.
3. After the files have been copied, you will be asked whether this is an "Administrator" installation or a "Workstation" installation. Select "Administrator." At this point the program will let you know that the files have been successfully copied. Click on and the system will begin to search for the Multiport Spooler VII connection. Wait until this process is completed.

- Now the introductory system-setup screen will appear. Click on **Start** and this screen will appear:

MPS-VII Black Box

How many MPS-VII units are you installing?

Single MPS-VII Installation

Two or more cascaded MPS-VII units

Number of units: 2

Configure Cascade Ports and Connections

Help Exit <Back Continue>

Select the radio button for “Two or more cascaded MPS-VII units.” A pulldown box will appear. Select the number of MPS-VIIs that you will be daisy chaining together. Make sure that the “Configure Cascade Ports...” box is checked as well. Click on **Continue**.

- The Multiport Spooler VII will briefly check the daisy chain connections. If all of the connections are good, you will move on to the Initialization screen. Select “Reset to Factory Defaults,” then click on **Continue**.

6. You will move to the Set Up Printers screen:

The screenshot shows a terminal window titled "MPS-VII" with a "Black Box" icon in the top right. The main title is "Set Up Printers". Below the title, there is a "Select Port" label followed by "<<Prev" and "Next>>" buttons. To the right of these buttons is the text "Box 1, Output 1 (Par)". Below this is the label "Assign Name to Printer:" followed by a text input field containing "Box 1, Output 1 (Par)". To the right of this field is a box labeled "End of Job Separator" containing a dropdown menu with "Form Feed Char" selected and a small square icon to its right. At the bottom of the window, there are four buttons: "Help", "Exit", "<Back", and "Continue>".

Notice the “Box 1, Output 1” description in the “Select Port” field. This indicates that the port you are configuring is on the same Multiport Spooler VII as the system administrator’s PC. Box 2 is the next unit in the daisychain, box 3 follows box 2, and so on. You can connect printers to any MPS-VII in the system, and all PCs in the chain will be able to print to them. Configure each printer on the system, then click on *Continue*.

7. You will move to the Set Up Users screen:

MPS-VII Black Box

Set Up Users

Select Port <<Prev Next>> Box 1, Port 1

Assign Name to User

Handshaking
 DTR/DSR

End of Job Timeout 20 Seconds

Baud Rate 19200 Baud

Help Exit <Back Continue>

By referring to the box and port numbers in the “Select Port” field, you can configure every user on each Multiport Spooler VII in the daisychain. Configure all the users as needed, and click on **Continue**.

8. You will handle the Print Direction and Define Banner Pages screens the same way you would if you were installing a single Multiport Spooler VII. After making all necessary configuration selections, go to the final screen, and the system will copy the **MPSVIIA.INI** file onto your software diskette.
9. Take this diskette and run **SETUP** on all of the workstation PCs.
10. Configure your printers and printer drivers as described in **Chapter 5**.

7. Troubleshooting

7.1 If a Connection or Print Test Fails

The “Connection Error” and “Timeout Error” messages, and failure of the parallel print test, are usually caused by cable problems. Troubleshoot physical connections as described in the following sections to determine the cause of these errors.

7.1.1 SERIAL INSTALLATION

If you cannot link to the Multiport Spooler VII from a PC connected to the MPS-VII through the PC’s serial port, there are several possible problems. If you troubleshoot in this order, you will most likely solve the problem quickly:

1. Examine the cable. Make sure it is securely attached to both the MPS-VII and the PC’s modular adapter. If it is, the cable might be “cross-pinned” as opposed to “pinned straight through.” If you are not using the cables provided with the MPS-VII, verify that the cables you have are pinned straight through by holding them as shown below. The color code should “read” the same from left to right on both connectors: Pin 1 to Pin 1, Pin 2 to Pin 2, Pin 3 to Pin 3, Pin 4 to Pin 4.

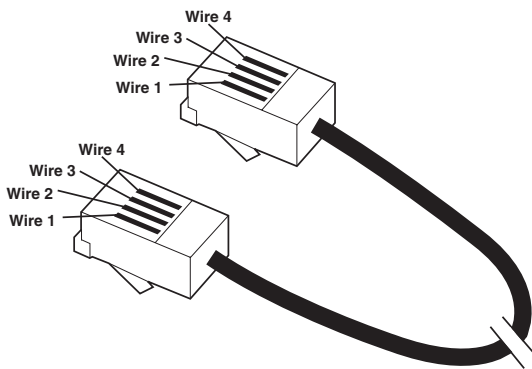

NOTE

In the event that you are using preinstalled cables (that is, cables already installed in the walls and ceiling of your office), you must ensure that your installer has tested to verify that the cables are pinned straight through all the way from the Multiport Spooler VII to the PC's modular adapter.

2. If the cable proves to be good, try swapping the modular adapter that you are using with another that was included in the package.
If you have built your own modular adapter, make sure that its pinning matches the template shown in **Appendix B**.
3. If everything else checks out OK, examine the PC's serial (COM) port. It is essential to make sure that the COM port is functional and that there are no interrupt conflicts.
4. If you still get a "Connection Error" or "Timeout Error," call your supplier for technical support (see **Section 7.6**).

7.1.2 PARALLEL INSTALLATION (PRINT-TEST FAILURE)

In the event that the parallel print test fails for a PC connected to a Multiport Spooler VII through the PC's parallel port and a Serial↔Parallel Converter III, first verify that the cable between the Converter and the MPS-VII is pinned straight through (see the explanation and illustration for step 1 on the previous page). If it is, follow steps 7 through 13 of **Section 4.4** on pages 36 and 37. If the print test still fails, call your supplier for technical support (see **Section 7.6**).

7.2 If You Have Problems Printing from Windows Applications

If you are unable to print after successfully installing the software on your PC, the most probable cause is that you did not reboot your PC after installing the software. You must reboot the PC in order for it to recognize the changes made to its **AUTOEXEC.BAT** file.

If you have rebooted and still cannot print, the most likely problem is that your printer drivers are not configured correctly. Try these steps:

1. Open the Multiport Spooler VII's program group and select the MPS-VII's Control program. If the program opens, then you are communicating with the Multiport Spooler VII. If the program does not open, you probably have a connection problem. Troubleshoot the physical connections as described in **Section 7.1**.
2. Once you have successfully opened the Control program, verify that the printer you want to print to is connected to the virtual port LPT1.DOS, as shown for "LaserJet" below.

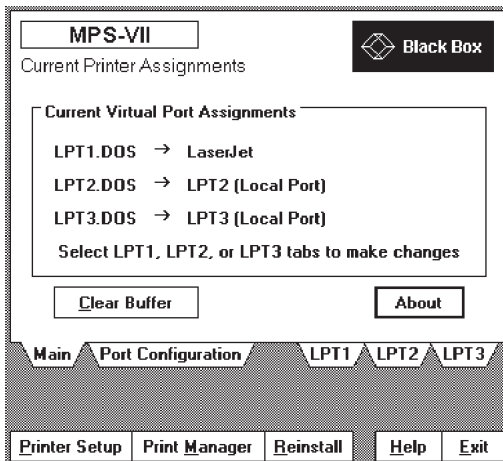

3. If the printer you wish to print to is not connected to LPT1.DOS, click on the tab for LPT1. This screen should appear:

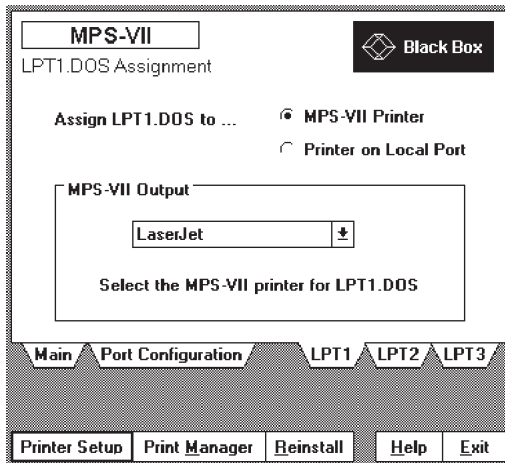

Make sure that the “MPS-VII Printer” radio button is selected. Use the pulldown box to select the correct printer.

4. To make sure that the printer driver is connected to LPT1.DOS, click on **Printer Setup**. This screen should appear:

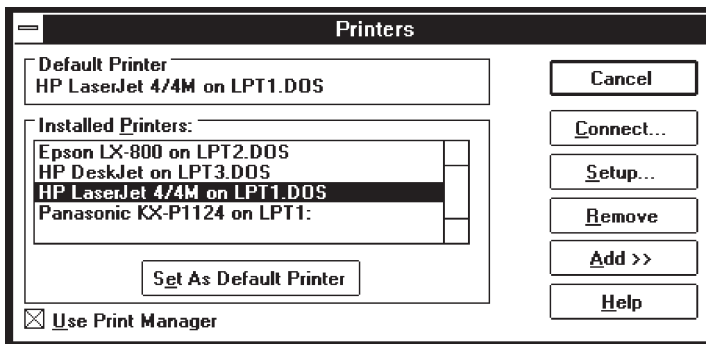

In the event that the printer driver is not connected to LPT1.DOS, click on **Connect**. You will see a list of ports. Scroll to the bottom of the list until you see LPT1.DOS or LPT1.OS2. Highlight that port and click on **OK**. Close the Printer Setup screen.

5. When you are in your Windows application preparing to print, make sure that you have selected the printer driver connected to LPT1.DOS.

These instructions are the same for printers connected to LPT2.DOS and LPT3.DOS as well. If you still can't print from your application, try printing from other applications. If you can print successfully from other applications, there is an application-specific problem; consult the manual for the problem application and call the company that created the application if necessary. If you can't print from any application, call your supplier for technical support (see **Section 7.6**).

7.3 If a Job Prints as Garbage

This is usually caused by one of four things: a data-rate mismatch, the wrong printer driver being selected, unplugged cables, or a too-short timeout.

7.3.1 DATA-RATE MISMATCH

There are two potential types of data-rate mismatches, parallel and serial, each of which requires a different troubleshooting technique. If nothing helps, call your supplier for technical support (see **Section 7.6**).

PCs Connected Through Their Serial Ports

When the system is first installed, the data rate set for a particular workstation will match the data rate that the system administrator has set for that workstation. However, if the system administrator makes a data-rate change for a particular user's input port, without making the change on that user's PC, then there will be a data-rate mismatch. The solution is to make sure that whenever the system administrator sets a new data rate for a particular port on the Multiport Spooler VII, he or she also sets the data rate to match on the corresponding PC. Only the system administrator has the ability to change the data rates of the MPS-VII's ports. To change a PC's data rate, the administrator must go to the PC itself or ask the user to do it through the MPS-VII's Control program.

PCs Connected Through Their Parallel Ports

If the PC is connected to the Multiport Spooler VII through one of its parallel ports and a Serial↔Parallel Converter III, follow steps 8 through 12 in **Section 4.4** on pages 36 and 37.

7.3.2 WRONG PRINTER DRIVER SELECTED

Print jobs may print out as garbage if the wrong printer driver is selected. Make sure that the printer driver in your application matches the printer you are sending to. Make sure that the printers selected under the LPT1, LPT2, and LPT3 tabs in the Multiport Spooler VII's Control program have the corresponding printer drivers connected to LPT1.DOS, LPT2.DOS, and LPT3.DOS respectively.

7.3.3 UNPLUGGED CABLES

If a cable connected to one of the Multiport Spooler VII's ports is not connected to anything at its other end, it will act as an antenna and might cause garbage to be printed. Disconnect from the MPS-VII any cables that are not connected to a PC or printer.

7.3.4 TIMEOUT TOO SHORT

If you are sending a large graphics file, you may find that the first portion of the job prints fine, but the second half of the job prints as garbage. This might be caused by the job taking a long time to compile in the PC and the Multiport Spooler VII assuming the job is finished. Try lengthening the "End of Job Timeout" value using the Port Configuration screen in the MPS-VII's Control program.

7.4 If the Printer Takes Too Long to Print Documents

Try these remedies:

1. Make sure the Windows Print Manager is set to "high" priority.
2. Try increasing the data rate.
3. If you are printing large documents, you might need to add memory to the Multiport Spooler VII (see **Appendix C**).

7.5 If You Have Printer-Selection Problems

7.5.1 UNABLE TO SELECT DIFFERENT PRINTERS

Most problems in printer selection and switching between printers will be caused by not having the printer drivers in Windows set up to match the printer assignments in the Multiport Spooler VII's Control program. In order to successfully switch between printers you must:

Make sure the printer listed in the Control program under the LPT1 tab is assigned to LPT1.DOS in the Windows Printer Setup.

Make sure the printer listed in the Control program under the LPT2 tab is assigned to LPT2.DOS in the Windows Printer Setup.

Make sure the printer listed in the Control program under the LPT3 tab is assigned to LPT3.DOS in the Windows Printer Setup.

To verify these assignments, take these steps:

1. Go to the MPS-VII's Control program and select the LPT1 tab.
2. Make sure that the "MPS-VII Printer" radio button is selected. Make a note of the printer that is selected. That is the printer the Multiport Spooler VII is expecting to see assigned to LPT1.DOS (or LPT1.OS2, depending on your system).
3. Click on Printer Setup. Verify that the proper printer driver is assigned to LPT1.DOS.

Perform the same operation for the printers selected in the LPT2 and LPT3 tabs.

When the printers assigned in the Control program match the printer drivers assigned to LPT1.DOS, LPT2.DOS, and LPT3.DOS, you may close the Control program and go to a Windows application. Your print job will automatically be directed to the printer you select in the application.

Remember: You are not selecting a printer in the MPS-VII's Control program. You are only setting up the printers connected to the Multiport Spooler VII to match the printer drivers assigned in Windows. The print job will *automatically be directed to the correct printer* when you select a printer driver assigned to LPT1.DOS, LPT2.DOS, or LPT3.DOS in your Windows application software.

If you still can't select different printers, call your supplier for technical support.

7.5.2 CAN'T PRINT TO PRINTER CONNECTED THROUGH A SERIAL↔PARALLEL CONVERTER III

First of all, verify that the cable you are using to connect the Serial↔Parallel Converter III to the Multiport Spooler VII or to the printer is pinned straight through (see the text and illustration for step 1 in **Section 7.1.1**). If it is, take these steps:

1. Run **SETUP.EXE** on the administrator PC. Verify that the MPS-VII serial port to which the printer has been physically connected matches the port it is listed on in **SETUP**. While you are in **SETUP**, note the data rate that the output port has been set to.
2. Turn off the PC. Unplug the Serial↔Parallel Converter III. Look at the Converter's controls and consult the Converter's manual to determine the Converter's current data-rate setting.
3. If the Converter's data rate doesn't match the data rate of the connected MPS-VII port, follow the directions in the Converter's manual and reset the Converter's data rate to match that of the port.
4. Make sure cable is securely connected to the proper parallel port on the PC. Make sure that cables are securely connected to the Converter and to the proper input port on the MPS-VII.
5. Plug the Converter back in. Turn the PC back on.
6. Once the data rate has been verified, go to the MPS-VII's Control program. Make sure that the printer has been selected under one of the LPT-port tabs and that the printer driver has been assigned to the corresponding LPTx.DOS port in Printer Setup.
7. If the problem persists, call your supplier for technical support.

7.5.3 CAN'T PRINT TO SERIAL PRINTER

First of all, verify that the cable you are using to connect the Multiport Spooler VII to the serial printer is a 4- or 6-wire straight-through cable (see the text and illustration for step 1 in **Section 7.1.1**). If it is, take these steps:

1. Verify that you are attaching the correct modular adapter to the serial printer. For HP and Epson compatible serial printers, use a DB25-male-to-RJ-12-female modular adapter (product code PI725A—see **Appendix B** for a pinout).
2. Run **SETUP** on the administrator PC. Verify that the port the printer is physically connected to is the same port it is listed under in **SETUP**.
3. While you are in **SETUP**, note the data rate that the output port has been set to. Verify that the printer has been set to that data rate.
4. Once the data rate has been verified, go to the MPS-VII's Control program. Make sure that the printer has been selected under one of the LPT-port tabs and that the printer driver has been assigned to the corresponding LPTx.DOS port in Printer Setup.
5. If the problem persists, call your supplier for technical support.

7.6 Contacting Your Supplier

If your Multiport Spooler VII seems to be malfunctioning, *do not attempt to alter or repair the unit*. Call your supplier. The problem may be solvable over the phone.

Before you call, make a record of the history of the problem. Your supplier will be able to provide more efficient and accurate assistance if you have a complete description, including:

- The nature and duration of the problem.
- When the problem occurs.
- The components involved in the problem.
- Any particular application that, when used, appears to create the problem or make it worse.

7.7 Shipping and Packaging

If you need to transport or ship your Multiport Spooler VII:

- Carefully package the Spooler. We recommend that you use the original container.
- If you're shipping the Spooler for repair, include its power supply. If you're returning the Spooler, include everything you received with the unit. Before you ship, contact your supplier to get a Return Materials Authorization (RMA) number.

Appendix A: Installation for DOS-Only Machines

NOTES

The DOS installation program is for workstations only—the system administrator's PC must be a Windows machine.

If you have any users on DOS-only machines, they will still be able to select printers on the Multiport Spooler VII, they will just do it slightly differently from the users on Windows machines.

A.1 Initial Steps

Follow the instructions below for DOS-only machines. The system-administrator installation must be complete, and you must use the diskette to which you copied the configuration file at the end of the system-administrator setup (see **Section 4.2**).

1. Insert the diskette containing the configuration file into your disk drive, and type **A:\INSTALL**.
3. After an introductory screen, you will be offered the option of using the default directory or giving a different directory for the Multiport Spooler VII files to be copied to. Make your selection and press **[ENTER]**. The files will be copied onto your hard drive and the system will briefly connect to the Multiport Spooler VII to make sure the cable connection is good. If you receive a "Connection Error" message at this point, see **Section 7.1**.
4. After a successful connection is made, you will receive a warning that your **AUTOEXEC.BAT** file will be modified. This modification will allow the printer-selection TSR to be loaded automatically upon booting your system. You should select "Yes" for this option. If for some reason you do not want the program to automatically alter your **AUTOEXEC.BAT** file, you will be given the commands on the screen so that you may manually enter them later.
5. You now move to the main menu. From here you can change the data rate or the end-of-job timeout, or test your cable connection, just as in the Windows program. The printer setup is slightly different, however.

A.2 Printer Selection in DOS

Highlight “Assign LPT1 Redirection” and press [ENTER]. Select “Make Assignment for LPT1.” A menu will appear, offering you three choices:

1. Assign LPT1 to a Multiport Spooler VII Printer
2. Assign LPT1 to Local Printer
3. Return to Main Menu

If you select “Assign LPT1 to a Multiport Spooler VII Printer,” you will be given a list of printers connected to the MPS-VII as named by the MPS-VII administrator. Select the printer you want assigned to LPT1.

If you select “Assign LPT1 to Local Printer” you will be given a list of ports on your PC (LPT1, COM1, COM2, etc.). Select the port you will connect the local printer to (a “local printer” is defined as a printer connected directly to a PC which will not be shared by the other MPS-VII users).

Notice, at the bottom of the DOS menu screen, the blue field that lists the printers currently assigned to your DOS LPT ports. The MPS-VII’s TSR will automatically route the print jobs to these printers when you select the correct LPT port in your DOS applications. For example, if your configuration is

LPT1 prints to “LaserJet” on Multiport Spooler VII

LPT2 prints to “Plotter” on Multiport Spooler VII

LPT3 prints Local Port on LPT1

then you will get these results:

Print jobs in DOS directed to LPT1 will go to the LaserJet connected to the Multiport Spooler VII.

Print jobs in DOS directed to LPT2 will be redirected to the plotter connected to the Multiport Spooler VII.

Print jobs in DOS directed to LPT3 will be redirected to the local printer connected to the PC’s LPT1 hardware port.

NOTE

This Multiport Spooler VII main menu is available for reconfiguration in DOS at any time—just go to the MPSVII subdirectory and run MPSVII.EXE.

Appendix B: Cable and Adapter Pinouts

B.1 The Cables and Adapters Illustrated

Figure B-1 below is a simplified overview of which modular adapters and cables go where in a single-unit Multiport Spooler VII installation.

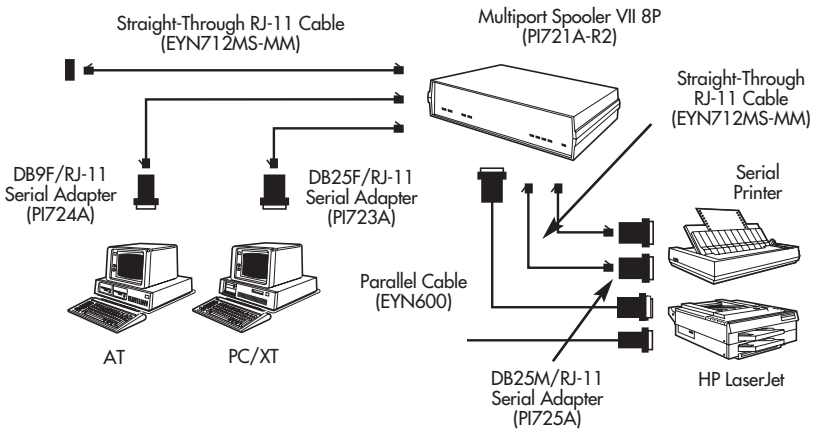

Figure B-1. Cabling overview for the Multiport Spooler VII.

B.2.2 PC (DB9 SERIAL PORT) TO MPS-VII MODULAR ADAPTER (PI724A)

Figure B-3 below shows the pin configuration for a DB9 female modular adapter that connects to a PC's DB9 serial port.

DB9 Female Connector	RJ-11 Female Connector	Signal Description
xx	1	Not used
2	2	Data from MPS-VII
6 & 8	3	Flow control from MPS-VII
3	4	Data to MPS-VII
5	5	Ground
xx	6	Not used

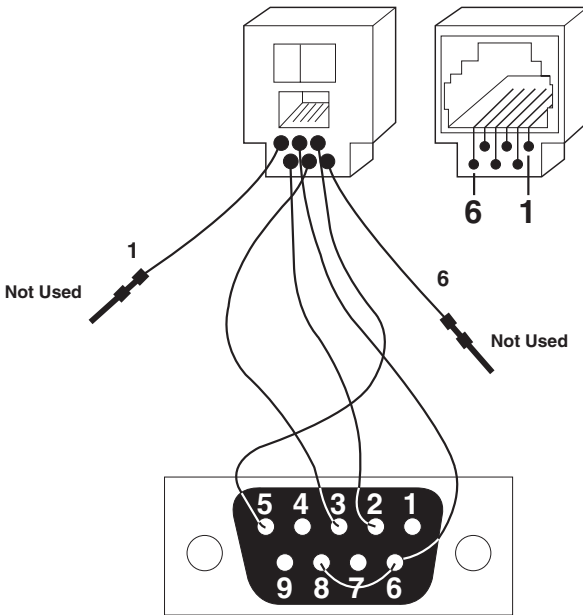

Figure B-3. Pinout for the PI724A.

B.2.3 MPS-VII TO STANDARD SERIAL PRINTER MODULAR ADAPTER (PI725A)

Figure B-4 below shows the pin configuration for a DB25 male modular adapter that connects to a DB25 (Epson, HP, and compatible) serial port on most standard serial printers.

DB25 Male Connector	RJ-11 Female Connector	Signal Description
xx	1	Not used
2	2	Data to MPS-VII
20	3	Flow control to MPS-VII
3	4	Data from MPS-VII
7	5	Ground
xx	6	Not used

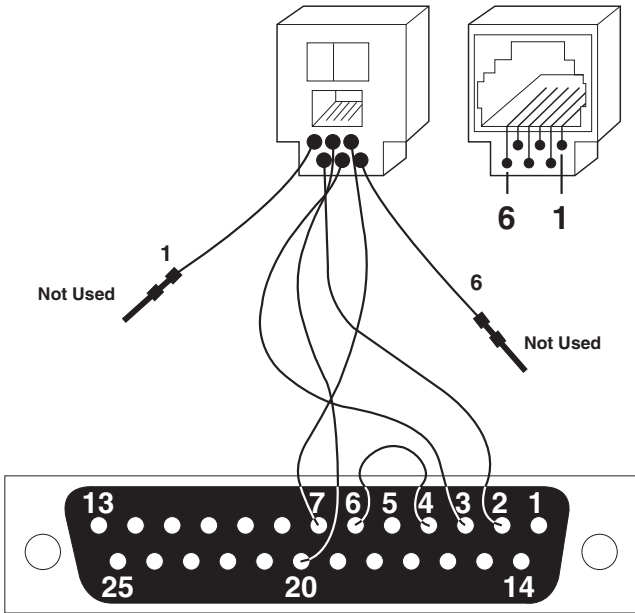

Figure B-4. Pinout for the PI725A.

B.3 Cable Pinouts

All cables that can be directly connected to the Multiport Spooler VII's serial ports should be 4- or 6-wire flat-satin or unshielded twisted-pair cable, pinned straight through (Pin 1 to Pin 1, Pin 2 to Pin 2, etc.). For a more thorough discussion and a list of product codes, see **Section 3.1.1.B**.

Cable running from a PC's parallel port to a Serial↔Parallel Converter III, or from a Multiport Spooler VII's parallel output port to a parallel printer or a Converter, should be standard IBM PC parallel-printer cable (EYN600).

Cable running between daisy-chained Multiport Spooler VIIs must be specially cross-pinned 6-wire unshielded twisted pair. Our product code for this is EHN066, but if you would like to build your own, pin it this way:

RJ-12P	RJ-12P
1	3
2	4
3	1
4	2
5	5

Appendix C: Memory Expansion

This appendix describes the Multiport Spooler VII's memory and tells you how to install additional memory modules. You can upgrade MPS-VIIs to contain as much as 16.2 MB of memory.

C.1 Multiport Spooler VII Memory

The Multiport Spooler VII uses its memory to store print jobs while waiting for the printer. Each Multiport Spooler VII comes with 256K of memory, which is enough to hold about 100 pages of textual data. Graphic print jobs usually require more memory per page. If the Multiport Spooler VII's memory becomes full, it slows down the rate at which it accepts data from the computer. This results in having to wait longer for your computer to finish sending the print job. To reduce the waiting time, we recommend that you increase the amount of memory to greater than the total size of all print jobs.

To add memory to the Multiport Spooler VII, install industry-standard 8-bit or 9-bit memory modules (SIMMs). Any SIMMs rated at a speed of 150 ns or less can be used. Acceptable memory sizes are 256K, 1 MB, and 4 MB. You can install up to four memory modules in each Multiport Spooler VII, and the sizes may be mixed.

You can order the following Memory Expansion modules:

- **PI726A** — 256K memory expansion
- **PI727A** — 1 MB memory expansion
- **PI728A** — 4 MB memory expansion

C.2 Installing Memory-Expansion Modules

Use the following procedure to install and test additional memory for a Multiport Spooler VII.

CAUTION

Memory modules can be damaged by static discharge. Please use proper grounding procedures.

1. Open the Multiport Spooler VII case by unscrewing the two screws on the bottom of the case.
2. Locate the four memory-module slots on the MPS-VII's circuit board. These are numbered MC1 through MC4.
3. If you need to remove the existing SIMM in order to add a larger one, move the plastic holding tabs on each side of the SIMM outward to allow the SIMM to tilt backward. Then it will easily slide out.
4. Orient the new SIMM so that when it is inserted the chips are facing the LEDs.

NOTE

MC1 must always be filled first, followed by MC2, MC3 and then MC4.

5. Place the SIMM into the slot so that the bottom edge is slanted against the socket, then push it forward until the plastic retaining clips click into the holes on each side of the SIMM.
6. Repeat steps 4 and 5 for all of the memory modules you wish to insert.
7. Close the MPS-VII's case and connect the MPS-VII to a printer. Make sure the printer is on line.
8. Press the reset button on the back of the Multiport Spooler VII. A test page will be ejected from the printer. Verify that there are no error messages and that all of the memory you have installed is registered on the test page. If you get an error message, one or more of the SIMMs might be bad. Try swapping out SIMMs to find the bad one.

The test page shows how much memory is installed in each of the SIMM slots. The number is displayed in kilobytes, so 1024 will display for a 1-MB module and 4096 will display for a 4-MB module. Make sure the numbers on the test page are correct for the modules that you have inserted.

Appendix D: Direct Commands

This appendix describes how to control the Multipoint Spooler VII with commands sent from the computer to the attached MPS-VII port. These commands are not necessary for most users, because the MPS-VII's Windows and DOS software perform the corresponding functions. However, these commands might help a programmer or administrator to make a system work.

NOTE

These commands might make it possible to access more of the system's functions from attached computers running operating systems other than DOS or Windows, but we cannot guarantee that this will be successful.

CAUTION!

The commands described in this appendix are intended for programmers or administrators who have in-depth knowledge of computers' serial ports and of the printing process. If they are used without careful planning and consideration of their effects, these commands can make system communication, especially in daisy-chained systems, unreliable or impossible.

Commands may be sent to the Multipoint Spooler VII in several ways. One way is to embed them in DOS ECHO commands entered from the DOS prompt or from DOS batch files (as described in **Section D.1** below). Another way is to embed the commands in print data sent to the MPS-VII. The third and most versatile way is to use a communications program to send them.

D.1 Sending Commands Using the DOS ECHO Instruction

You can enter the ECHO command at the DOS prompt to send direct commands to the Multiport Spooler VII. You can also put ECHO in batch files to send the commands automatically. Be aware, however, that this method is only useful for commands that change settings. This is because you can send commands that ask for information, but the computer will not be able to display the information that comes back.

Before you can send direct commands with ECHO, you must determine which physical port you will be using (one of PRN, COM1 through COM4, or LPT1 through LPT3, but see the CAUTION below). Then use the DOS MODE command to redirect the logical port (LPT1 through LPT3) to that physical port. For example, **C:\MODE LPT1:=COM1:** redirects the logical port LPT1 to the physical serial device COM1. If the computer is connected to the MPS-VII through one of the computer's serial ports (see the CAUTION below), be sure to properly configure the port: You can use the MODE command or the included SETBAUD utility to set the data rate, and the MODE command to set the data bits to 8, stop bits to 1, and parity to none.

CAUTION!

If a given computer is connected to the MPS-VII through one of the computer's parallel ports and a serial-parallel converter, the only type of direct commands you can send are those that change settings, no matter what method you're using to send the commands. This is because you can send commands that ask for information, but the IBM PC parallel interface can't carry the response back to the computer.

Once the logical port has been redirected, you can start transmitting commands with ECHO. For example, assuming LPT1 has been redirected to the physical port connected to the MPS-VII, the command **C:\ECHO ~~P3>LPT1:** sends the command “~~P3” the MPS-VII. Note that there is no space before the “>” character. The ECHO command automatically adds the necessary <CR-LF> (see **Section D.2**) to the end of the command text. The command “~~P3” (select printer 3) and other commands are defined in **Section D.3**.

D.2 Command Format

Commands are special character strings sent to the Multipoint Spooler VII. All commands begin with the special two-character prefix “~~” (double tilde) and end with a “<CR-LF>” (carriage return + line feed) terminator. The characters between the prefix and the terminator are the command instruction. If the command sequence is not terminated (with <CR-LF>) or is invalid, the MPS-VII interprets the entire sequence as data.

General command syntax:

~~	“Beginning of command” prefix.
<Command>	A character string comprising a command sequence. Valid commands are described in the following sections. All commands must be entered in uppercase letters.
<CR-LF>	A carriage return and line feed are necessary to terminate each command.

D.3 Command Descriptions

This section describes each of the direct commands accepted by the Multipoint Spooler VII. The commands are separated into two categories:

- **User Commands** — Commands which may be entered by a user on any port. These commands are listed in **Section D.3.1**.
- **Administrative Commands** — Commands available only to the user on Input Port 1. (Normally the system administrator is connected to this port.) These commands are listed in **Section D.3.2**.

D.3.1 USER COMMANDS

<BREAK> (Data-Rate Determination)

Format

<Break>

Description

The break signal may be used to verify or determine the data rate of an input port. When your computer or terminal transmits the break signal to the Multiport Spooler VII's input port, the input port will respond with a single ASCII "U" character. Set the data rate of either your computer/terminal or the MPS-VII so that the computer or terminal is able to properly interpret this character.

B (Set Data Rate)

Format

~~Bn<CR-LF>

Arguments

n — A "command code" number from 1 to 8 that corresponds to a given data rate, as follows:

<i>Command Code</i>	<i>Data Rate in bps</i>
1	1200
2	2400
3	4800
4	9600
5	19,200
6	38,400
7	57,600
8	115,200

Description

Sets the currently selected MPS-VII port to communicate at the data rate corresponding to the command code you enter. The 57,600-bps and 115,200-bps data rates are not available on the output ports. The default data rate is 19,200 bps (command code 5) on the input ports and 9600 bps (command code 4) on the serial output ports.

NOTE

Make sure that the command has had time to be fully processed (about 800 ms) before attempting to use the affected port.

DE (Define End Page)

Format

~~DE<string><CR-LF>

Arguments

<string>—A string of characters up to 80 bytes long.

Description

Defines the string of characters you want to print on the end-of-job banner page. The end-of-job banner page is a page that can be added to the end of a job to make it easier to separate that job from other jobs on the printer tray. If you use this command, make sure you enable the end-of-job banner-page feature with the SEY (Set End Page ON) command. You can use the special characters “^” and “|” in the <string> to represent <Esc> and <CR-LF>, respectively. Refer to the entry for the DT (Define Title Page) command for how to add a banner page at the beginning of a job.

DEF (Select Default Printer)

Format

~~DEFp<CR-LF>

Arguments

p — A number from 0 to 4. Values of 1 to 4 correspond to a default printer (default output port on the MPS-VII). A value of 0 turns off the default printer option.

Description

Specifies the default printer (default MPS-VII output port) you want to use. When you define a default output port, that port is used for all print jobs unless you use the P (Select Printer) command to specify a specific output for a print job. Use the DEF X (Select Default Daisychained Printer) command instead of this one if your system is daisychained.

DEF X (Select Default Daisychained Printer)**Format**

```
~~DEFpXb<CR-LF>
```

Arguments

- p — A number from 0 to 4. Values of 1 to 4 correspond to a default printer (default output port on the MPS-VII). A value of 0 turns off the default printer option.
- b — A number from 1 to 9 corresponding to the address of the daisychained MPS-VII unit to which the desired default printer is connected. (See the entry for the X [Assign Address to Daisychained Unit] command in **Section D.3.2.**)

Description

This command performs the same function as DEF (Select Default Printer), but allows users to select printers connected to any MPS-VII in a daisychain, because it contains the address of the daisychained MPS-VIII to which the printer is connected. Any jobs following this command will be directed to the default output box and printer unless the P X (Select Daisychained Printer) command is issued prior to the job. Use the DEF (Select Default Printer) command instead of this one if your system is not daisychained.

DT (Define Title Page)**Format**

```
~~DT<string><CR-LF>
```

Arguments

- <string> — A string of characters up to 80 bytes long.

Description

Defines the string of characters you want to print on the title banner page. The title banner page is a page which may be inserted at the beginning of a job to make it easier to separate from other jobs on the printer tray. If you use this command, make sure you enable the title-page feature with the STY (Set Title Page ON) command. You can use the special characters “^” and “|” to represent <Esc> and <CR-LF>, respectively. Refer to the entry for the DE (Define End Page) command for how to add a banner page at the end of a job.

EOJ (End of Job)

Format

~~EOJ<CR-LF>

Description

This command instructs the Multipoint Spooler VII that there will be no more data sent for the current job. This saves time by allowing the unit to skip the end-of-job timeout delay (see the entry for the T [Set End-of-Job Timeout] command). This command must be used after each job if the end-of-job timeout is disabled.

FF (Generate Form Feed)

Format

~~FF<CR-LF>

Description

Inserts a form-feed sequence into the print job. The system uses the default form-feed sequence the administrator has defined for the destination printer (see the entry for the DFF [Define Form-Feed Sequence] administrative command in **Section D.3.2**). If this command is issued when no print job is being processed, it has no effect.

G (Get Port Number)

Format

~~G<CR-LF>

Description

Returns the port number and MPS-VII daisychain address associated with the port that receives the command, as follows:

Response — Pp<CR-LF>

Meaning — p = The number (1 through 4, 8, or 12, depending on the MPS-VII model) of the input port

Response — Bb<CR-LF>

Meaning — b = The address (0 through 9) of the daisychained MPS-VII

HD (Set Port for DTR Flow Control)**Format**

```
~~HD<CR-LF>
```

Description

This instruction causes the connected MPS-VII input port to use the DTR hardware signal for flow control. (If you have been using robust X-ON flow control, make sure to change the flow-control setting on your computer to DTR before sending any more data or commands.) See also the entry for the HX (Set Port for Robust X-ON Flow Control) command.

HX (Set Port for Robust X-ON Flow Control)**Format**

```
~~HX<CR-LF>
```

Description

This instruction causes the connected MPS-VII input port to use the robust X-ON software method for flow control: The MPS-VII sends the computer an X-OFF character when it is not ready to accept more data, and the X-ON character when it becomes ready to accept data. The X-ON character is also transmitted once every second while the input port is ready. The state of the DTR signal does not affect the operation of the port when this method is used.

If you have been using DTR flow control, make sure to change the flow-control setting on your computer to robust X-ON before sending any more data or commands. See also the entry for the HD (Set Port for DTR Flow Control) command.

KA (Kill All Jobs)**Format**

```
~~KAp<CR-LF>
```

Arguments

p — A number from 1 to 4 corresponding to the desired printer (MPS-VII output port).

Description

Deletes all print jobs you have sent to the specified printer from the computer you are using. This command only works when the computer is connected to a standalone (non-daisy-chained) MPS-VII.

KF (Kill First Job)

Format

~~KFp<CR-LF>

Arguments

p — A number from 1 to 4 corresponding to the desired printer (MPS-VII output port).

Description

Deletes the print job from the computer you are using that is listed first (highest, earliest) in the print queue of the specified printer. This command only works when the computer is connected to a standalone (non-daisy chained) MPS-VII.

KL (Kill Last Job)

Format

~~KLp<CR-LF>

Arguments

p — A number from 1 to 4 corresponding to the desired printer (MPS-VII output port).

Description

Deletes the print job from the computer you are using that is listed last (lowest, latest) in the print queue of the specified printer. This command only works when the computer is connected to a standalone (non-daisy chained) MPS-VII.

L (Loopback Test)

Format

~~L<CR-LF>

Description

This command allows the MPS-VII to test its RTS signal. When the MPS-VII receives this command, it will toggle DTR low for approximately 100 ms, then return to the ready state. If the loopback test fails, the MPS-VII will return a failure message.

MOVE (Move to Top of Queue)**Format**

```
~~MOVE<CR-LF>
```

Description

Moves the print job which follows the command to the top of the print queue. This command only works when the computer is connected to a standalone (non-daisy chained) MPS-VII, or when the printer is on the same MPS-VII in the daisy chain as the computer.

N (Number of Copies)**Format**

```
~~Nnnn <CR-LF>
```

Arguments

nnn — The number of copies you want to print, from 1 to 255. A value of 0 causes 1 copy to be printed.

Description

Specifies the number of copies you want of the print job which follows the command. The maximum number of copies allowed is 255. If you issue this command with an argument of 0, the system prints one copy. If you issue this command with an argument greater than 255, the command is ignored and is passed to the printer as data.

P (Select Printer)**Format**

```
~~Pp<CR-LF>
```

Arguments

p — A number from 1 to 4 corresponding to the desired printer (MPS-VII output port).

Description

Specifies the printer to which you want to direct the print job which follows the command. If the “default printer” option is OFF (that is, if the DEF [Select Default Printer] command most recently sent to the MPS-VII had an argument of 0), the system uses the output port you specify with this command until you send it another P (Select Printer) command. If the “default printer” option is ON (that is, if the DEF [Select Default Printer] command most recently sent to the MPS-VII specified output port 1, 2, 3, or 4 as the default), this command remains in effect for the following print job only. Use the P X (Select Daisychained Printer) command instead of this one if your system is daisychained.

P X (Select Daisychained Printer)

Format

~~PpXb<CR-LF>

Arguments

- p — A number from 1 to 4 corresponding to the desired printer (MPS-VII output port).
- b — A number from 1 to 9 corresponding to the address of the daisychained MPS-VII unit to which the desired printer is connected. (See the entry for the X [Assign Address to Daisychained Unit] command in **Section D.3.2.**)

Description

This command performs the same function as P (Select Printer), but allows users to select printers connected to any MPS-VII in a daisychain, because it contains the address of the daisychained MPS-VII to which the printer is connected.

If the “default daisychained printer” option is OFF (that is, if the DEF X [Select Default Daisychained Printer] command most recently sent to the MPS-VII system had an argument of 0), the system uses the output port you specify with this command until you send it another P X (Select Daisychained Printer) command. If the “default daisychained printer” option is ON (that is, if the DEF X [Select Default Daisychained Printer] command most recently sent to the MPS-VII system specified output port 1, 2, 3, or 4 of one of the units as the default), this command remains in effect for the following print job only.

Use the P (Select Printer) command instead of this one if your system is not daisychained.

SEN (Set End Page OFF)

Format

~~SEN<CR-LF>

Description

Instructs the Multiport Spooler VII not to print a banner page after each job. To reverse this, issue an SEY (Set End Page ON) command.

SEY (Set End Page ON)**Format**

```
~~SEY<CR-LF>
```

Description

Instructs the Multiport Spooler VII to print a banner page at the end of each job sent by this computer. Use the DE (Define End Page) command to enter the characters that should appear on this page. To turn off the printing of end-of-job banner pages, issue an SEN (Set End Page OFF) command.

SFFN (Set End-of-Job Form Feed OFF)**Format**

```
~~SFFN<CR-LF>
```

Description

Instructs the Multiport Spooler VII not to send a form-feed sequence after each job sent by this computer. To reverse this, issue an SFFY (Set End-of-Job Form Feed ON) command.

SFFY (Set End-of-Job Form Feed ON)**Format**

```
~~SFFY<CR-LF>
```

Description

Instructs the Multiport Spooler VII to send a form-feed sequence to the printer at the end of each job. Use the DFF (Define Form-Feed Sequence) administrative command to define this printer's form-feed sequence for the MPS-VII (see **Section D.3.2**). To have the MPS-VII stop sending the form-feed sequence, issue an SFFN (Set End-of-Job Form Feed OFF) command.

STN (Set Title Page OFF)

Format

~~STN<CR-LF>

Description

Instructs the Multiport Spooler VII not to print a banner page before each job sent by this computer. To reverse this, issue an STY (Set Title Page ON) command.

STY (Set Title Page ON)

Format

~~STY<CR-LF>

Description

Instructs the Multiport Spooler VII to print a banner page before each print job sent by this computer. Use the DT (Define Title Page) command to enter the text that should appear on this page. To turn off the printing of title banner pages, issue an STN (Set Title Page OFF) command.

T (Set End-of-Job Timeout)

Format

~~Tn<CR-LF>

Arguments

n — A “timeout-value code” number from 0 to 9 that corresponds to a given end-of-job timeout, as follows:

<i>Timeout-Value Code</i>	<i>Timeout in seconds</i>
0	0 (no timeout)
1	5
2	10
3	20
4	30
5	45
6	60
7	90
8	150
9	240

Description

Specifies the end-of-job timeout value (the amount of time the MPS-VII waits idle before assuming that the print job is complete) for this computer. The default value is 20 seconds (timeout-value code 3). If you disable the timeout by setting this option to 0, you must issue an EOJ (End of Job) command after sending each print job to the MPS-VII. It is important for the MPS-VII to detect the end of the job so that it can release the output printer to other users when a job is complete.

D.3.2 ADMINISTRATIVE COMMANDS

This section describes the commands for administrative functions. Input Port 1 of a single Multiport Spooler VII, or the first MPS-VII in a daisychain, is the system-administrator port; these commands will be ignored unless they come from this port. (Daisychained units must be cabled to each other properly, as described in **Chapter 6** of the MPS-VII manual, for the commands to work properly.)

1 to 9 (Address Prefix for Daisychained Unit)**Format**

~~a<Command string><CR-LF>

Arguments

a — A number from 1 to 9 corresponding to the address of a daisychained MPS-VII.

<Command string> — Any valid user or administrative command (do not include the tildes and <CR-LF> in this string).

Description

The address of a daisychained unit may be included at the beginning of any valid command. The address determines which MPS-VII unit will receive and process the command. This feature allows the administrator to check or change the settings of any unit in the system through the system-administrator port. If you have not yet assigned daisychain addresses, you must do so with the X (Assign Address to Daisychained Unit) command before you can send commands with this address prefix.

CC (Apply Next Command to Daisychain-Output Port)

Format

~~CC<CR-LF>

Description

This command instructs the MPS-VII to apply the next command from Port 1 to the daisychain-output port. With this feature, the administrator can check or change the data rate and other settings of the daisychain port from Port 1. This command is only valid for daisychained units. To have the MPS-VII apply the next command to the input or output ports, issue a CI (Apply Next Command to Input Port) or CO (Apply Next Command to Output Port) command respectively.

CI (Apply Next Command to Input Port)

Format

~~CIpp<CR-LF>

Arguments

pp — The number of the input port from 1 to 4, 8, or 12 (depending on the MPS-VII model).

Description

This command instructs the MPS-VII to apply the next command from Port 1 to the specified input port. With this feature, the administrator can check or change the data rate and other settings of the input port from Port 1. To have the MPS-VII apply the next command to the output or daisychain-output ports, issue a CO (Apply Next Command to Output Port) or CC (Apply Next Command to Daisychain-Output Port) command respectively.

CO (Apply Next Command to Output Port)**Format**

```
~~COp<CR-LF>
```

Arguments

p — The number of the output port from 1 to 4.

Description

This command instructs the MPS-VII to apply the next command from Port 1 to the specified output port. With this feature, the administrator can check or change the data rate and other settings of the output port from Port 1. To have the MPS-VII apply the next command to the input or daisychain-output ports, issue a CI (Apply Next Command to Input Port) or CC (Apply Next Command to Daisychain-Output Port) command respectively.

DFF (Define Form-Feed Sequence)**Format**

```
~~DFFp<FF string><CR-LF>
```

Arguments

p — The number of the printer (MPS-VII output port, from 1 to 4) that will be receiving the form-feed sequence.

<FF string> — Form-feed string up to 10 bytes long. Use the special characters “^” and “|” to represent <Esc> and <CR-LF>, respectively.

Description

Defines for the Multiport Spooler VII the specified printer's form-feed sequence (that is, the character sequence that causes that printer to perform a form-feed; this will vary depending on the printer—consult your printer's manual). This sequence will be sent to the printer at the end of the title banner page, the end of the job, and/or the end of the end-of-job banner page, when any of these features are enabled. Refer to the entries for the FF (Generate Form Feed), SFFN (Set End-of-Job Form Feed OFF), and SFFY (Set End-of-Job Form Feed ON) user commands.

I (Return Port Information)**Format**

```
~~I<CR-LF>
```

Description

Returns the configuration settings for Port 1, or for the port you select with the CC (Apply Next Command to Daisychain-Output Port), CI (Apply Next Command to Input Port), or CO (Apply Next Command to Output Port) command. The following information is returned in this order:

```
Nnnn<CR-LF> — Port number
S<CR-LF> — Port is a serial port
P<CR-LF> — Port is a parallel port
I<CR-LF> — Port is an input port
O<CR-LF> — Port is an output port
M<CR-LF> — Port is the master (system-administrator) port
Bn<CR-LF> — Data-rate code n (see the entry for the B
           [Set Data Rate] user command)
DT<title string><CR-LF> — Title banner-page definition
DE<end string><CR-LF> — End banner-page definition
Tn<CR-LF> — Timeout code n (see the entry for the T
           [Set End-of-Job Timeout] user command)
Dp[Xb]<CR-LF> — Default printer p (and, for daisychained
           systems, the default MPS-VII unit b)
HXON<CR-LF> — Port uses robust X-ON flow control
HDTR<CR-LF> — Port uses DTR flow control
*<CR-LF> — End of response
```

MODEC (Switch to Command Mode)**Format**

```
~~MODEC<CR-LF>
```

Description

Puts the receiving Multipoint Spooler VII in Command Mode: Command processing speeds up, but data communication slows down. Make sure you use the MODED (Switch to Data Mode) command to switch the MPS-VII back to Data Mode when you want to return to normal operation.

MODED (Switch to Data Mode)**Format**

~~MODED<CR-LF>

Description

Puts the receiving unit back in Data Mode if you have switched it to Command Mode with the MODEC (Switch to Command Mode) command. Data Mode is the normal operating mode, and the Multiport Spooler VII defaults to this mode when it is reset.

R (Reset)**Format**

~~R<CR-LF>

Description

Resets all options (for all ports on the receiving unit) to their original factory settings.

S (Return System Information)**Format**

~~S<CR-LF>

Description

Returns the number of input ports, serial output ports, parallel output ports, and the total amount of memory installed on the receiving Multiport Spooler VII:

Ipp<CR-LF> — Number *pp* of input ports

Sp<CR-LF> — Number *p* of serial output ports

Pp<CR-LF> — Number *p* of parallel output ports

Mnnnnn <CR-LF> — *nnnnn* kilobytes of total memory

Xb<CR-LF> — Daisychain address *n*

V<string><CR-LF> — MPS-VII version description

*<CR-LF> — End of response

V (Return System Information from Next Unit)

Format

~~V<CR-LF>

Description

This command instructs the MPS-VII to transmit an S (Return System Information) command to the next MPS-VII in the daisychain. See the entry for that command for a description of the returned information.

W (Return Status Report or Reset Error Condition)

Format

~~Wx<CR-LF>

Arguments

x — A number from 1 to 3 (return that status-report page) or the letter “R” (reset the error flags on status page 3)

Description

This command is used to either return one of the status-report pages to the system-administrator port, or to reset the error variables shown on status-report page 3. The command options have these effects:

- 1 Return status-report page 1. This shows the Multipoint Spooler VII version information, amount of memory installed in the unit, daisychain address, and number of input and output ports.
 - 2 Return status-report page 2. This shows the current configuration settings of all of the MPS-VII’s input and output ports.
 - 3 Return status-report page 3. This page shows the number of framing or overrun errors on each of the MPS-VII’s input ports, how many files are in each printer queue, the number of available memory blocks, and whether the memory has been full.
- R** Reset the errors and the memory-full flag shown on status-report page 3.

X (Assign Address to Daisychained Unit)

Format

~~Xb<CR-LF>

Arguments

b — A number from 0 to 9. Values of 1 to 9 are used as daisychain addresses. The value 0 returns a unit to standalone (non-daisychained) operation.

Description

Assigns the Multiport Spooler VII that is currently connected to the system administrator's computer a daisychain address from 1 to 9, or returns it to standalone (non-daisychained) operation with an argument of 0. Each MPS-VII in a daisychain must have a unique daisychain address. See also the entry for the Y (Assign Address to Next Unit in Daisychain) command.

Y (Assign Address to Next Unit in Daisychain)**Format**

~~Yb<CR-LF>

Arguments

b — A number from 0 to 9. Values of 1 to 9 are used as daisychain addresses. The value 0 returns a unit to standalone (non-daisychained) operation.

Description

Instructs the Multiport Spooler VII that is currently connected to the system administrator's computer to send an X (Assign Address to Daisychained Unit) command to the next unit in the daisychain. Each MPS-VII in a daisychain must have a unique daisychain address.

Z (Generate Break on Daisychain-Output Port)**Format**

~~Z<CR-LF>

Description

Instructs the Multiport Spooler VII that is currently connected to the system administrator's computer to send a break signal (<Break> [Data-Rate Determination] command) out of its daisychain-output port. The response from the next unit in the daisychain is returned to the system-administrator port. This feature is useful for making sure that the data rates of the ports connecting the two units are correct.

D.4 Quick Reference

Table D-1 below shows a summary of the Multipoint Spooler VII's user commands. These commands are accepted at any port. For detailed descriptions, see **Section D.3.1**.

Table D-2 on the next page shows a summary of the MPS-VII's administrative commands. These commands are accepted only if they are received at the system administrator's port (Port 1). For detailed descriptions, see **Section D.3.2**.

Table D-1. Summary of User Commands

Command	Format
DATA-RATE DETERMINATION	[break]
SET DATA RATE	~~Bn<CR-LF>
DEFINE END PAGE	~~DE<string><CR-LF>
SELECT DEFAULT PRINTER	~~DEFp<CR-LF>
SELECT DEFAULT DAISYCHAINED PRINTER	~~DEFpXb<CR-LF>
DEFINE TITLE PAGE	~~DT<string><CR-LF>
END OF JOB	~~EOJ<CR-LF>
GENERATE FORM FEED	~~FF<CR-LF>
SET PORT FOR DTR FLOW CONTROL	~~HD<CR-LF>
SET PORT FOR ROBUST X-ON FLOW CONTROL	~~HX<CR-LF>
GET PORT NUMBER	~~G<CR-LF>
KILL ALL JOBS	~~KAp<CR-LF>
KILL FIRST JOB	~~KFp<CR-LF>
KILL LAST JOB	~~KLp<CR-LF>
LOOPBACK TEST	~~L<CR-LF>
MOVE TO TOP OF QUEUE	~~MOVE<CR-LF>
NUMBER OF COPIES	~~Nnnn<CR-LF>
SELECT PRINTER	~~Pp<CR-LF>
SELECT DAISYCHAINED PRINTER	~~PpXb<CR-LF>
SET END PAGE OFF	~~SEN<CR-LF>
SET END PAGE ON	~~SEY<CR-LF>
SET END-OF-JOB FORM FEED OFF	~~SFFN<CR-LF>
SET END-OF-JOB FORM FEED ON	~~SFFY<CR-LF>
SET TITLE PAGE OFF	~~STN<CR-LF>
SET TITLE PAGE ON	~~STY<CR-LF>
SET END-OF-JOB TIMEOUT	~~Tn<CR-LF>

Table D-2. Summary of Administrative Commands

Command	Format
ADDRESS PREFIX FOR DAISYCHAINED UNIT	~~a<Cmd String><CR-LF>
APPLY NEXT COMM. TO DAISYC.-OUTPUT PORT	~~CC<CR-LF>
APPLY NEXT COMMAND TO INPUT PORT	~~Cipp<CR-LF>
APPLY NEXT COMMAND TO OUTPUT PORT	~~COp<CR-LF>
DEFINE FORM-FEED SEQUENCE	~~DFFp<FF string><CR-LF>
RETURN PORT INFORMATION	~~I<CR-LF>
SWITCH TO COMMAND MODE	~~MODEC<CR-LF>
SWITCH TO DATA MODE	~~MODED<CR-LF>
RESET	~~R<CR-LF>
RETURN SYSTEM INFORMATION	~~S<CR-LF>
RETURN SYSTEM INFO. FROM NEXT UNIT	~~V<CR-LF>
RETURN STATUS REPORT, Page 1	~~W1<CR-LF>
Page 2	~~W2<CR-LF>
Page 3	~~W3<CR-LF>
RESET ERROR CONDITIONS	~~WR<CR-LF>
ASSIGN ADDRESS TO DAISYCHAINED UNIT	~~Xb<CR-LF>
ASSIGN ADDR. TO NEXT UNIT IN DAISYCHAIN	~~Yb<CR-LF>
GENERATE BREAK ON DAISYC.-OUTPUT PORT	~~Z<CR-LF>

Glossary

AUTOEXEC.BAT file

A batch file that contains a series of commands, which runs automatically when your PC is booted up. Commands in this file will be executed every time the PC is turned on or reset.

Banner page

A page that prints either before or after each print job (typically on a shared printer) which separates that print job from others as they pile up on the printer tray. Banner pages usually give the user's name, extension, port number or any identifying information that the system administrator feels is critical.

Buffer

Additional memory installed in a PC, printer, or printer-sharing device which will store data temporarily while the printer is busy. As the printer is freed up, the buffer will release the data.

Data rate

Data-communication speed, usually measured in Kilobits per second (Kbps) for serial communication.

DB9 male

A connector in the "D-subminiature" family, typically used for serial input/output on PCs. Easily identified by counting the pins in the connector: 1 row of 5 pins, 1 row of 4 pins. To plug into this port, a cable or adapter must have a DB9 female connector.

DB25 female

A connector in the "D-subminiature" family, typically used for parallel output on PCs or serial input on printers. Easily identified by counting the holes in the connector: 1 row of 13 holes, 1 row of 12 holes. To plug into this port, a cable or adapter must have a DB25 male connector.

DB25 male

A connector in the “D-subminiature” family, typically used for serial input/output on PCs. Easily identified by counting the pins in the connector: 1 row of 13 pins, 1 row of 12 pins. To plug into this port, a cable or adapter must have a DB25 female connector.

DTR/DSR

Data Terminal Ready/Data Set Ready. The hardware flow-control (handshaking) lines of the RS-232 interface. DTR/DSR handshaking is the most common form of flow control, and is used by virtually all PCs. Contrast with *Robust X-ON/X-OFF* or *X-ON/X-OFF*.

End-of-Job Separator

A command sent to the printer at the conclusion of each print job. Will reset the printer and eject the last page if needed.

End-of-Job Timeout

The length of time the Multiport Spooler VII will wait for more data from the computer after the last data has been sent during a print job. If the specified time has elapsed and no characters are received, the MPS-VII automatically ends the print job to accommodate other print jobs waiting to be printed.

Fast Printing Direct to Port

This Windows checkbox controls printing through DOS. For printing through the Multiport Spooler VII, this checkbox should be disabled.

Flow Control (Handshaking)

Exchange of signals at the beginning of a data-communications session. During this exchange, the two systems confirm each other’s specifications. Flow control will let the PC know when the printer is ready to receive. The MPS-VII’s flow-control options are “DTR/DSR” and “Robust X-ON” (robust X-ON/X-OFF). Default for the MPS-VII is DTR/DSR. Virtually every PC uses DTR/DSR flow control.

Local Printer

A printer directly connected to a port on a PC. The local printer is used only by the PC to which it is connected and cannot be shared.

Modular Adapters

Adapters that convert PC serial ports to telephone-style jacks. The inputs on the Multiport Spooler VII are telephone style RJ-12 (six-wire RJ-11) jacks, so the serial ports on the PCs must be adapted to this style of cabling in order to connect to the MPS-VII.

Parallel

The transmission of bits over multiple wires at the same time. Accomplished by devoting a wire for each bit of a byte. Parallel data transmission is fast, but is usually reliable only across short distances. Contrast with *serial*.

Parallel Port

A port on your PC, usually DB25 female, used for sending (and sometimes receiving) parallel data.

Printer Driver

Software that formats a print job for a particular printer. Each printer has its own printer driver that must be used to format any print jobs sent to it. In Windows you must select the correct printer driver before sending your print job to the printer.

REDIR

A TSR developed for the Multiport Spooler VII that allows print jobs to be redirected automatically based on the printer driver selected in Windows and DOS applications.

Robust X-ON/X-OFF

A type of software flow control similar to *X-ON/X-OFF*, but involving persistent transmission of the X-ON character. Contrast with *DTR/DSR*.

Serial

The transmission of bits in sequence over a single wire. Serial data transmission is slow but is reliable even across vast distances. Contrast with *parallel*.

Serial Port

A port on your PC, usually DB9 male or DB25 male, used for sending and receiving serial data.

SIMMs

Single In-Line Memory Modules. SIMMs typically have memory chips mounted on a small PC board designed to connect easily into memory slots on the main PC board. The Multiport Spooler VII typically ships with 256K RAM of buffer memory installed. Additional SIMMs can be installed to increase the buffer size.

Straight-Through Cable

A cable which is wired so that Pin 1 connects to Pin 1, Pin 2 connects to Pin 2, 3 to 3, etc. Except for cables between daisy-chained units, the Multiport Spooler VII will only work with straight-through cable.

System Administrator

The user of the computer connected to input port 1 of the Multiport Spooler VII (this PC should be the first one cabled and installed). The system administrator can configure and control the entire MPS-VII system.

Target Printer

The printer driver and port currently selected for a particular print job in an application.

TSR

Terminate and Stay Resident. A software program which can be loaded into the computer's memory and is available for use at any time. The Multiport Spooler VII's TSR, **REDIR**, redirects print jobs from the virtual ports LPT1.DOS, LPT2.DOS, and LPT3.DOS to the port that is physically connected to the Multiport Spooler VII.

Virtual Port

A logical port defined by DOS. These ports can be assigned even if they do not physically exist in your computer. Thus, printers can be assigned to LPT2.DOS and LPT3.DOS, even if there is no actual LPT2 or LPT3 port on the PC.

Workstation

A PC that is connected to any port other than the Multiport Spooler VII's input port 1. A Multiport Spooler VII workstation can print to all attached printers, but it can configure only its own data rate and timeout.

X-ON/X-OFF

A type of flow control, typically used by mainframes, in which the communicating devices transmit special X-ON and X-OFF characters to each other to signal “send” and “don’t send” respectively. Often called software flow control. Contrast with *Robust X-ON/X-OFF* and *DTR/DSR*.

Index

- 1**
 1 to 9 (Address Prefix for
 Daisychained Unit)
 command93
- 4**
 4-wire cable.....14
- 6**
 6-wire cable.....14
- <**
 <Break> character, signal83, 99
 <BREAK> (Data-Rate
 Determination) command83, 99
 <CR-LF> character sequence82, 84-85
 <Esc> character84-85
- A**
 Administrative commands93
 Apple® computers31
 Assign Name to Printer field.....29
 Assign Name to User field.....30
AUTOEXEC.BAT file27, 33, 35, 63, 71, 102
- B**
 B (Set Data Rate) command83
 Banner pages32, 84-85, 91-92, 102
 Baud Rate fields29-30, 54
 “Beginning of command”
 prefix82
 Break*see* <Break>
 Buffer9, 102, 104

C	
Cascading	55
CC (Apply Next Command to Daisychain-Output Port) command	94
Centronics connectors.....	18
Centronics male-to-male cable	20
Change Connection function	54
CI (Apply Next Command to Input Port) command	94
CO (Apply Next Command to Output Port) command.....	95
COM port	62
Command Mode	96-97
Computers supported	6
Configure Cascade Ports box	58
Connecting parallel printers to serial outputs	20
Connecting PCs	11
Connecting printers	18
Connecting serial printers to parallel outputs.....	21
Connection Error message.....	61-62, 71
Connectors on the MPS-VII	7
Contacting your supplier.....	69
Control program	9, 11, 40, 45, 48, 50-51, 63, 65-69
Cross-pinned cable	14-16, 55, 61, 77
Custom Sequence code	29

D	
Daisychain address	93, 98-99
Daisychain-output port.....	94-95, 99
Daisychaining	9, 28, 55-60, 77, 105
Data bits	6
Data format	6
Data Mode	96
Data pins	74-76
Data rate	6, 8, 17, 19-21, 29-30, 38-39, 54, 65-66, 68-69, 83, 99, 102, 105

Data-rate mismatch	65
DB9 connectors.....	12-13, 17, 73, 75, 102, 104
DB25 connectors.....	7-8, 12-13, 16-21, 69, 73-74, 76, 102-104
DCE setting on Converter	21
DE (Define End Page)	
command	84, 91
DEF (Select Default Printer)	
command	84, 89
DEF X (Select Default	
Daisy chained Printer)	
command	85, 90
Default daisy chained printer.....	85, 90
Default output port.....	84-85
Default printer	84-85, 89
Define Banner Pages screen	32, 60
DFE (Define Form-Feed	
Sequence) command	91, 95
Diagnostics	51
Direct commands.....	80
Disk space required	6
DOS.....	8, 11, 23, 31, 44, 71-72, 80, 103-105
DOS-only machines	71
DT (Define Title Page)	
command	85, 92
DTE setting on Converter	17, 20
DTR/DSR flow control.....	6, 8-9, 30, 87, 103

E

ECHO command (DOS)	81
ECN25C-MM (product code)	21
EHN066 (product code)	55, 77
EL04MS (product code)	16
End-of-job banner page.....	84, 91, 95
End-of-job separator	29, 103
End-of-job timeout	30, 54, 66, 86, 92-93, 103
EOJ (End of Job) command	86, 93
Epson printers, standards	19, 69, 76
EQN380-MM (product code)	20

EYN600 (product code)	17-18, 21, 73, 77
EYN712MS-MM (prod. code)	16, 73
EYN714MS-MM (prod. code)	16

F	
Fast Printing Direct to Port	26, 35, 103
FF (Generate Form Feed)	
command	86
Flat-satin cable	14, 16, 77
Flow control.....	6, 8-9, 30, 74-76, 87, 103-106
Form Feed Character code	29
Form-feed sequence	86, 91, 95

G	
G (Get Port Number)	
command	86
Ground pins	74-76

H	
Handshaking	8, 30, 102
Hardware installation	11
HD (Set Port for DTR Flow	
Control) command.....	87
HP PCL Reset code	29
HP printers, standards.....	19, 69, 76
HX (Set Port for Robust X-ON	
Flow Control) command	87

I	
I (Return Port Information)	
command	96
Indicators	7
Initialization screen	58
Input port 1	8, 16, 22, 30, 34, 55, 57, 105
Input ports	6, 8
INSTALL.EXE	8, 11, 23, 71
Interfaces	6

K

KA (Kill All Jobs) command	87
KF (Kill First Job) command.....	88
KL (Kill Last Job) command.....	88

L

L (Loopback Test) command.....	88
LEDs	7, 22
Local printers.....	48, 72, 103
Loopback test.....	88
LPT1 port	41, 46, 48-50, 64, 72
LPT1.DOS virtual port	11, 41, 43-44, 46-48, 50, 63-67, 105
LPT1.OS2 virtual port	43, 65, 67
LPT2 port.....	41, 72
LPT2.DOS virtual port.....	11, 41, 45-48, 50, 65-67, 105
LPT3 port.....	41, 72
LPT3.DOS virtual port.....	11, 41, 45-50, 65-67, 105

M

Mainframes.....	31, 106
Memory	6, 66, 78-79, 102, 105
Memory expansion	78-79
MODE command (DOS)	81
MODEC (Switch to Command Mode) command	96
MODED (Switch to Data Mode) command	97
Modular adapters	12-13, 16-17, 19-20, 61-62, 69, 73-76, 104
Modular cable	14, 16
MOVE (Move to Top of Queue) Queue) command	89
MPSVII.EXE	72
MPSVIIA.INI	33-34, 60
MTBF	7

N

N (Number of Copies)	
command	89
No Connection message	25, 34
Non DOS machines	31

O

On-line help	25, 34, 54
--------------------	------------

P

P (Select Printer) command	84, 89
P X (Select Daisychained Printer) command	85, 90
Parallel cable	73
Parallel installation of PCs.....	17
Parallel output ports	6-7, 77
Parallel-port print test.....	24-25, 34, 36, 39, 62
Parallel-printer cable	17-18, 21, 77
Parallel-printer installation	18
Parity	6
PI115A (product code)	17, 20-21
PI723A (product code)	13, 73-74
PI724A (product code)	13, 73, 75
PI725A (product code)	17-20, 69, 73, 76
PI726A (product code)	78
PI727A (product code)	78
PI728A (product code)	78
Pinouts	74-77
Plenum-rated cable	14, 16
Port Configuration screen.....	52, 66
Power LED	22, 38
Power specifications.....	7
Power supply	9, 22, 70
Print Direction screen	31, 60
Print Manager	26, 35, 66
Print test (diagnostic).....	53-54
Printer drivers	11, 43-44, 47, 49-50, 60, 66-68, 104
Printer selection in DOS	72

Printer Setup42, 44-46, 48-50, 64-65, 67-69
 Printer-selection problems67
 Printer-selection screen37
 Printing from Windows
 applications44, 63
 Printing to a local printer48
 Product features.....8
 PVC cable14, 16

R

R (Reset) command.....97
 Rear panels of MPS-VIIs10
 Rear panels of PCs16-17
REDIR27, 104-105
 Reset button6, 22, 38
 Reset to Factory Defaults29, 58
 RJ-118, 12, 19, 73, 104
 RJ-127-8, 12, 16, 19, 69, 74-77, 104
 Robust X-ON/X-OFF flow
 control6, 8, 30, 87, 103-104
 RS-232 cable21

S

S (Return System Information)
 command97
 SEN (Set End Page OFF)
 command91
 Serial input ports17
 Serial installation of PCs12
 Serial output (printer) ports6-8, 19-20
 Serial-printer installation.....19
 Serial↔Parallel Converter III17, 20-22, 25, 29, 34, 36, 38, 54, 57, 62, 66,
 68, 77
 Set Up Printers screen29, 59
 Set Up Users screen30, 60
SETUP.EXE8, 11, 23-24, 26, 34, 36, 47, 60, 68-69
 SEY (Set End Page ON)
 command84, 91

SFFN (Set End-of-Job Form	
Feed OFF) command	91
Sharing a single printer	41
Sharing more than three	
printers	48
Sharing multiple printers	45
Shipping and packaging	70
SIMMs	9, 78-79, 105
Size	7
Software configuration	23
Software installation	6, 23
Specifications	6-7
Status-report page	98
STN (Set Title Page OFF)	
command	92
Stop bit	6
STY (Set Title Page ON)	
command	85, 92
Straight-through cable	14-16, 18, 55, 61-62, 68-69, 73, 77, 105
System administrator's PC	8, 11, 22-23, 25-27, 30, 33-34, 55, 57, 59
System requirements	6
System-Administrator Setup	24, 57
System-setup screens	28

T

T (Set End-of-Job Timeout)	
command	92
Target printer	44, 46, 105
Test Connection function	52
Throughput	6, 8
Timeout Error message	61-62
Title banner page	85, 92, 95
TSR	8-9, 31, 46-48, 71-72, 104-105

U

Unshielded twisted-pair (UTP) cable	14, 16, 55, 77
User commands	83
User controls	6

V

V (Return System Information from Next Unit) command	98
Virtual ports	11, 41-43, 48-50, 63, 105

W

W (Return Status Report or Reset Error Condition) command	98
Weight	7
Windows	8-9, 11, 23-24, 26, 31, 35, 40, 44, 49-50, 65-67, 71, 80, 103-104
Workstation Setup	34

X

X (Assign Address to Daisy chained Unit) command	93, 98
X-ON/X-OFF	104, 106

Y

Y (Assign Address to Next Unit in Daisychain) command	99
--	----

Z

Z (Generate Break on Daisychain-Output Port) command	99
--	----

~

~~	82
----------	----

TRADEMARKS USED IN THIS MANUAL

Apple is a registered trademark of Apple Computer, Inc.

Centronics is a registered trademark of Centronics Corporation.

DeskJet, HP, and LaserJet are registered trademarks of Hewlett-Packard.

AT, IBM, and PS/2 are registered trademarks, and PC/XT is a trademark, of International Business Machines Corporation.

Panasonic is a registered trademark of Matsushita Electric Industrial Co., Ltd.

Microsoft is a registered trademark, and Windows is a trademark, of Microsoft Corporation.

Epson is a registered trademark of Seiko Epson Corporation.

All other trademarks are the property of their respective owners.

NOTES

NOTES

NOTES

NOTES