



SEPTEMBER 1995

LB9901A-AUI

LB9901AE-AUI

LB9901A-BNC

LB9901AE-BNC

LB9901A-RJ

LB9901AE-RJ

LB9901A-TST

LB9901AE-TST

## Workgroup MiniBridge

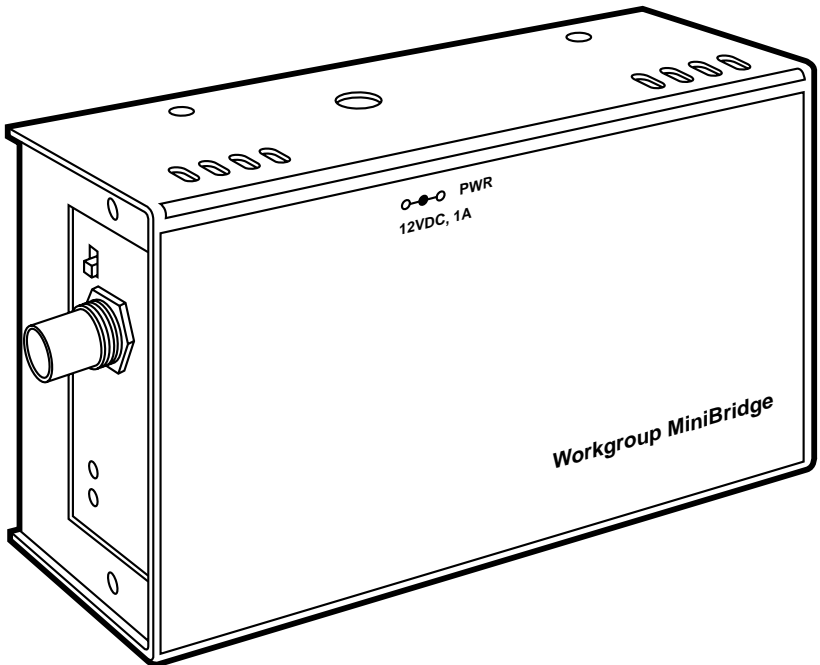

**CUSTOMER  
SUPPORT  
INFORMATION**

Order toll-free in the U.S. 24 hours, 7 A.M. Monday to midnight Friday: **877-877-BBOX**  
FREE technical support, 24 hours a day, 7 days a week: Call **724-746-5500** or fax **724-746-0746**  
Mail order: **Black Box Corporation**, 1000 Park Drive, Lawrence, PA 15055-1018  
Web site: [www.blackbox.com](http://www.blackbox.com) • E-mail: [info@blackbox.com](mailto:info@blackbox.com)

**FEDERAL COMMUNICATIONS COMMISSION  
AND  
INDUSTRY CANADA  
RADIO FREQUENCY INTERFERENCE STATEMENTS**

This equipment generates, uses, and can radiate radio frequency energy and if not installed and used properly, that is, in strict accordance with the manufacturer's instructions, may cause interference to radio communication. It has been tested and found to comply with the limits for a Class A computing device in accordance with the specifications in Subpart J of Part 15 of FCC rules, which are designed to provide reasonable protection against such interference when the equipment is operated in a commercial environment. Operation of this equipment in a residential area is likely to cause interference, in which case the user at his own expense will be required to take whatever measures may be necessary to correct the interference.

Changes or modifications not expressly approved by the party responsible for compliance could void the user's authority to operate the equipment.

*This digital apparatus does not exceed the Class A limits for radio noise emission from digital apparatus set out in the Radio Interference Regulation of Industry Canada.*

*Le présent appareil numérique n'émet pas de bruits radioélectriques dépassant les limites applicables aux appareils numériques de classe A prescrites dans le Règlement sur le brouillage radioélectrique publié par Industrie Canada.*

**TRADEMARKS**

ST® is a registered trademark of American Telephone and Telegraph Company.

UL® is a registered trademark of Underwriters Laboratories Incorporated.

Velcro® is a registered trademark of Velcro USA Inc.

*All applied-for and registered trademarks are the property of their respective owners.*

**NORMAS OFICIALES MEXICANAS (NOM)  
ELECTRICAL SAFETY STATEMENT****INSTRUCCIONES DE SEGURIDAD**

1. Todas las instrucciones de seguridad y operación deberán ser leídas antes de que el aparato eléctrico sea operado.
2. Las instrucciones de seguridad y operación deberán ser guardadas para referencia futura.
3. Todas las advertencias en el aparato eléctrico y en sus instrucciones de operación deben ser respetadas.
4. Todas las instrucciones de operación y uso deben ser seguidas.
5. El aparato eléctrico no deberá ser usado cerca del agua—por ejemplo, cerca de la tina de baño, lavabo, sótano mojado o cerca de una alberca, etc..
6. El aparato eléctrico debe ser usado únicamente con carritos o pedestales que sean recomendados por el fabricante.
7. El aparato eléctrico debe ser montado a la pared o al techo sólo como sea recomendado por el fabricante.
8. Servicio—El usuario no debe intentar dar servicio al equipo eléctrico más allá a lo descrito en las instrucciones de operación. Todo otro servicio deberá ser referido a personal de servicio calificado.
9. El aparato eléctrico debe ser situado de tal manera que su posición no interfiera su uso. La colocación del aparato eléctrico sobre una cama, sofá, alfombra o superficie similar puede bloquea la ventilación, no se debe colocar en libreros o gabinetes que impidan el flujo de aire por los orificios de ventilación.
10. El equipo eléctrico deber ser situado fuera del alcance de fuentes de calor como radiadores, registros de calor, estufas u otros aparatos (incluyendo amplificadores) que producen calor.

11. El aparato eléctrico deberá ser conectado a una fuente de poder sólo del tipo descrito en el instructivo de operación, o como se indique en el aparato.
12. Precaución debe ser tomada de tal manera que la tierra física y la polarización del equipo no sea eliminada.
13. Los cables de la fuente de poder deben ser guiados de tal manera que no sean pisados ni pellizcados por objetos colocados sobre o contra ellos, poniendo particular atención a los contactos y receptáculos donde salen del aparato.
14. El equipo eléctrico debe ser limpiado únicamente de acuerdo a las recomendaciones del fabricante.
15. En caso de existir, una antena externa deberá ser localizada lejos de las líneas de energía.
16. El cable de corriente deberá ser desconectado del cuando el equipo no sea usado por un largo periodo de tiempo.
17. Cuidado debe ser tomado de tal manera que objetos líquidos no sean derramados sobre la cubierta u orificios de ventilación.
18. Servicio por personal calificado deberá ser provisto cuando:
  - A: El cable de poder o el contacto ha sido dañado; u
  - B: Objetos han caído o líquido ha sido derramado dentro del aparato; o
  - C: El aparato ha sido expuesto a la lluvia; o
  - D: El aparato parece no operar normalmente o muestra un cambio en su desempeño; o
  - E: El aparato ha sido tirado o su cubierta ha sido dañada.

# Contents

Section	Page
1. Specifications .....	7
1.1 Technical Specifications.....	7
1.2 Specifications—Repeater Port Modules (RPM) .....	9
1.3 Specifications—Bridge Port Modules (BPM) .....	9
2. Introduction .....	10
2.1 Inspecting the Package and Product.....	10
2.2 Product Description .....	10
2.2.1 Chassis.....	11
2.2.2 Available Models.....	12
2.3 Repeater Port Modules (RPMs).....	13
2.3.1 Repeater Port Module—TP (Twisted Pair) .....	13
2.3.2 Repeater Port Module—BNC.....	15
2.3.3 Repeater Port Module—AUI.....	15
2.3.4 Repeater Port Module—FST (Fiber ST, Twist-lock Connector) .....	18
2.4 Bridge Port Modules (BPMs).....	19
2.4.1 Bridge Port Module—TP .....	19
2.4.2 Bridge Port Module—BNC.....	21
2.4.3 Bridge Port Module—AUI.....	22
2.4.4 Bridge Port Module—FST .....	23
2.5 Features and Benefits .....	24
2.6 Applications .....	25
3. Installation.....	30
3.1 Locating the Workgroup MiniBridge.....	30
3.1.1 Table-Top or Shelf-Mounting.....	30
3.1.2 Wall (or Vertical Surface) Mounting .....	30
3.1.3 Direction of the Workgroup MiniBridge.....	32
3.1.4 Installation Notes for the AUI Models.....	33
3.2 Connecting Ethernet Media .....	33
3.2.1 Connecting Twisted Pair (RJ-45, Shielded or Unshielded).....	34
3.2.2 Connecting ThinNet 10BASE2 (BNC) .....	35
3.2.3 Connecting ThickNet 10BASE5 (AUI) .....	35
3.2.4 Connecting Fiberoptic (ST-type, “Twist-lock”) .....	36
3.3 Replacing PM Cards .....	38
4. Operation .....	42
4.1 Workgroup MiniBridge Functionality.....	42
4.2 LEDs .....	49
5. Troubleshooting .....	50
5.1 Before Calling for Technical Support.....	50
5.2 Calling Technical Support .....	50

# 1. Specifications

## 1.1 Technical Specifications

### *Performance*

**Data Rate** — 10 Mbps

**RPM Partitioning** — Enforced after 32 consecutive collisions

**RPM Reconnect** — Occurs after 512 bits error-free transmission

**BPM Auto-Learning Address List** — 256-node capacity

**BPM Filtering and Forwarding Rate** — 14,880 pps max.

### *Maximum Ethernet Segment Lengths*

**10BASE-T (twisted-pair)** — 100 m (328 ft)

**10BASE2 ThinNet (BNC)** — 185 m (607 ft)

**10BASE5 ThickNet** — 500 m (1,640 ft)

**FOIRL Multi-Mode Fiberoptic** — 1 km (3,281 ft)

**10BASE-FL Multi-Mode Fiberoptic** — 2 km (6,562 ft)

### *Network Standards*

**Ethernet V1.0/2.0 IEEE 802.3** — 10BASE-T, 10BASE2, 10BASE2,  
10BASE-FL and FOIRL

### *Operating Environment*

**Ambient Temperature** — 32° to 122°F (0° to 50°C)

**Storage Temperature** — 4° to 140°F (-20° to 60°C)

**Ambient Relative Humidity** — 10% to 95% (non-condensing)

### *Power Supply (External)*

**Power Input** — LB9901A-RJ, -BNC, -AUI, -TST, and -AST: 95-125-VAC  
at 60Hz;

LB9901AE-RJ, -BNC, -AUI, -TST, and -AST: 200-250-VAC at 50 Hz

**Power Consumption** — 12 watts max.

### *Connectors*

**Two Port Modules per chassis: one Bridge Port Module (BPM) and one Repeater Port Module (RPM)—**

LB9901A-RJ, LB9901AE-RJ: (1) BPM with RJ-45 female, (1) RPM with RJ-45 female

LB9901A-BNC, LB9901AE-BNC: (1) BPM with BNC female, (1) RPM with BNC female,

LB9901A-TST, LB9901AE-TST: (1) RPM with RJ-45 female, (1) BPM with ST fiber,

LB9901A-AST, LB9901AE-AST: (1) RPM with AUI, (1) BPM with ST® fiber

### *Packaging*

**Enclosure** — High-strength sheet metal. Suitable for wiring-closet shelf, wall- or desktop-mounting.

**Port Module Slots** — 2

**Size** — 3"H x 6"W x 1.7"D (7.6 x 15 x 4.4 cm)

**Weight** — Chassis with modules installed: 1.3 lb. (0.6 kg), Power supply: 1.1 lb. (0.5 kg)

**Port Slot Cut-Out** — 2.2" x 0.75" (5.6 x 1.9 cm)

**Cooling Method** — Convection

### *LED Indicators on Chassis*

**PWR** — Power, green LED, steady ON indicates there is AC power

### *Agency Approvals*

**UL® listed (UL 1950), cUL, CE**

**FCC Part 15, Class A**

## 1.2 Specifications—Repeater Port Modules (RPMs)

<b>RPM Type</b>	<b>BNC</b>	<b>AUI</b>	<b>Fiber</b>	<b>TP<sup>1</sup></b>
Front access	yes	yes	yes	yes
Connector type	BNC F	DB15 F	Fiber ST	RJ-45
Partition (PART) LED	yes	yes	yes	yes
Receive (RX) LED	yes	yes	yes	yes
LINK LED	N/A	N/A	yes	yes
Switch on faceplate	yes <sup>2</sup>	N/A	N/A	yes <sup>3</sup>

### NOTES

<sup>1</sup>The RJ-45 connector is shielded; it accepts RJ-45 eight-pin plugs for unshielded and shielded twisted-pair wiring.

<sup>2</sup>Internal termination switch for BNC; no “T” connector is required.

<sup>3</sup>MDI-X (Media Dependent Interface-Crossover) switch for RJ-45 up-link; no crossover cable is required.

## 1.3 Specifications—Bridge Port Modules (BPMs)

<b>RPM Type</b>	<b>BNC</b>	<b>AUI</b>	<b>Fiber</b>	<b>TP<sup>1</sup></b>
Connector type	BNC F	DB15 F	ST	RJ-45
Switch on faceplate	yes <sup>2</sup>	N/A	N/A	yes <sup>3</sup>
FWD-I LED	yes	yes	yes	yes
FWD-X LED	yes	yes	yes	yes
LINK LED	N/A	N/A	yes	yes

### NOTES

<sup>1</sup>The RJ-45 connector is shielded; it accepts RJ-45 eight-pin plugs for unshielded and shielded twisted-pair wiring.

<sup>2</sup>Internal termination switch for BNC; no “T” connector is required.

<sup>3</sup>MDI-X (Media Dependent Interface-Crossover) switch for RJ-45 up-link; no crossover cable is required.



## 2. Introduction

### 2.1 Inspecting the Package and Product

Examine the shipping container for obvious damage before installing this product; notify the carrier of any damage that you believe occurred during shipment or delivery. Make sure that the items listed below are included in your package:

- (1) Workgroup MiniBridge with one Bridge Port Module and one Repeater Port Module installed
- (1) External power supply, either 115 VAC (for LB9901A models) or 230 VAC (for LB9901AE models)
- (2) Mounting brackets
- (2) Mounting screws
- (1) Velcro® tape section, approximately 3 inches (7.6 cm) long
- This user's manual

If any of these items are missing, contact your supplier immediately. If you need to return the unit, use the original shipping container.

Remove the Workgroup MiniBridge from the shipping container. Keep the container in case you later need to ship or store the unit.

### 2.2 Product Description

The Workgroup MiniBridge is a plug-and-play miniature local bridge available in a variety of configurations to accommodate any combination of standard Ethernet media. It contains one Bridge Port Module (BPM) and one Repeater Port Module (RPM), enclosed in a lightweight, compact, rugged metal enclosure. An external power supply is included. You can easily install the Workgroup MiniBridge in an existing network, either on a wiring-closet shelf, on a table-top, or on a wall.

The Workgroup MiniBridge is ideally suited to workgroups that have their own local server, and have become congested because of heavy local traffic combined with excess outside network traffic. In this environment, the MiniBridge can bridge-isolate the workgroup and local servers from the rest of the network, since traffic is typically between the workgroup users and their servers.

## 2.2.1 CHASSIS

The chassis houses the main repeater circuit board, one Bridge Port Module, and one Repeater Port Module. The main repeater board is used to power the two PM cards and as a connection plane between the cards. The RPM port simply behaves as a repeater port, and relays all packets in both directions. The BPM gives the Workgroup MiniBridge its bridge functionality by making a

filter/forward decision on each packet based on the contents of its address table (see **Section 4.1** for more details). The top side of the chassis has one DC power jack for the included external power supply, and one green power (PWR) LED, which lights when DC power is present. Each PM is equipped with a media interface connector.

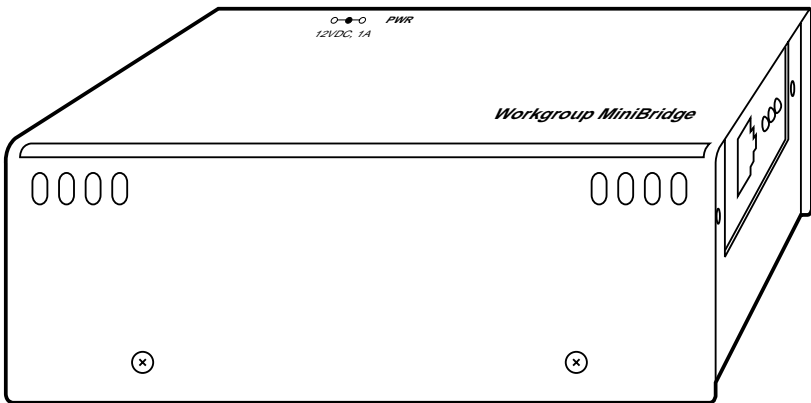

**Figure 2-1. Workgroup MiniBridge.**

The Port Modules are located at the ends of the MiniBridge, with the RPM usually located on the right end of the unit and the BPM on the left. For clarity, the ends of the MiniBridge are labeled “Workgroup port (RPM)” on the right and “Upstream port (BPM)” on the left. Since the unit is directional, orient and connect the ports properly during installation (see **Section 3.1.3**) for best results.

The external power supply is one of two types:

- 115 VAC, 60 Hz, which has a small transformer integral with a power-outlet plug.
- 230 VAC, 50 Hz, which has a small transformer integral with an IEC-type power plug for a user-supplied AC power cord with a power-outlet plug.

Both types also include a lightweight DC power cord for connection to the power jack on the MiniBridge.

### 2.2.2 AVAILABLE MODELS

The following pre-configured models are available:

- Workgroup MiniBridge RJ-45 (LB9901A-RJ and LB9901AE-RJ): Contains one RJ-45 Bridge Port Module and one RJ-45 Repeater Port Module.
- Workgroup MiniBridge BNC (LB9901A-BNC and LB9901AE-BNC): Contains one BNC Bridge Port Module and one BNC Repeater Port Module.
- Workgroup MiniBridge AUI (LB9901A-AUI and LB9901AE-AUI): Contains one AUI Bridge Port Module and one AUI Repeater Port Module.
- Workgroup MiniBridge TP/Fiber (LB9901A-TST and LB9901AE-TST): Contains one RJ-45 Repeater Port Module and one Fiber-ST Bridge Port Module.
- Workgroup MiniBridge AUI/Fiber (LB9901A-AST and LB9901AE-AST): Contains one AUI Repeater Port Module and one Fiber ST Bridge Port Module.

**NOTE**

**If the configuration you need is not listed above, contact your supplier to special-order it.**

**2.3 Repeater Port Modules (RPMs)**

Five connector types are available, including BNC, AUI, ST, and RJ-45.

**2.3.1 REPEATER PORT MODULE—TP (TWISTED PAIR)**

The RPM-TP card supports Ethernet twisted-pair segments of any standard length. It has a single RJ-45 connector, which is shielded to minimize emissions and to accept either unshielded twisted-pair or shielded twisted-pair segment connections.

The RPM-TP also has a slide switch for cascaded or uplink connections, so you don't need to use a special twisted-pair crossover cable. With the switch in the UP (or LEFT) position, the RPM-TP port is configured for uplink connections (i.e., connections to another repeater or hub). With the switch in the DOWN (or RIGHT) position, the RPM-TP is configured for workstations and other user-device connections. If the LINK LED is lit, the switch is set properly. If the LINK LED is not lit, change the switch setting.

The RPM-TP will support 10BASE-T unshielded twisted-pair wiring (UTP) environments with maximum segment distances up to 325 ft (100 m) or shielded twisted-pair wiring (STP) with distances up to 500 ft (150 m). The RPM contains an internal transceiver.

**NOTE**

**For the RPM-TP, set the MDI-X Crossover Switch to DOWN (or RIGHT) for workstations and user connections, and UP (or LEFT) for uplink connections to other hubs.**

The RJ-45 pins normally (when the TP crossover switch is DOWN or RIGHT) conform to the standard for hub-to-user twisted pair wiring:

- 1=receive +
- 2=receive -
- 3=transmit +
- 6=transmit -

Pins 4 and 5 are not used.

When the TP crossover switch is UP or LEFT, the pins conform to the standard for uplinks using twisted-pair cabling:

- 1=transmit +
- 2=transmit -
- 3=receive +
- 6=receive -

Pins 4 and 5 are not used.

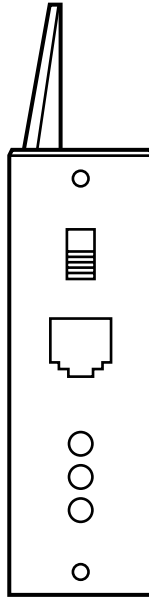

**Figure 2-2. Repeater Port Module—TP (Twisted Pair).**

**2.3.2 REPEATER PORT MODULE—BNC**

The Repeater Port Module—BNC has a standard 10BASE2 coax connector for ThinNet BNC connections.

You can terminate a link that the RPM—BNC is connected to by flipping its internal slide switch to the DOWN (or RIGHT) position, so you don't need a "T" connector and a 50-ohm terminator. However, since certain applications require a "T" connector used as a tap, you can also set the link this way via the same

switch. Simply slide the switch to the UP (or RIGHT) position to use the RPM with a "T" connector and 50-ohm terminator.

The RPM—BNC includes one partition (PART) and one receive (RX) LED, which you can see from the front of the card. The PART LED flashes amber when the segment is automatically partitioned. As soon as normal transmission resumes, the segment will be automatically reestablished. The RX LED lights green when data is received.

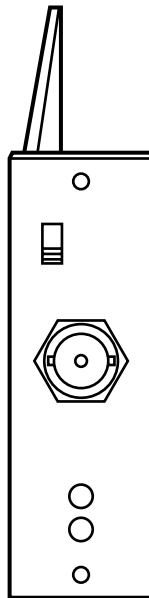

**Figure 2-3. Repeater Port Module—BNC.**

### 2.3.3 REPEATER PORT MODULE—AUI

This module has a DB15 AUI female connector and a slide-lock, and functions as an IEEE 802.3 repeater. It connects to a 10BASE5 (ThickNet) backbone or to any AUI segments. When connecting to a ThickNet segment, you must use a transceiver. The RPM—AUI is also a “universal” Ethernet media interface: You can use it with a variety of mini-transceivers to connect to any media type.

The RPM—AUI has Partition (PART) and Receive (RX) LEDs that function the same as the LEDs on the RPM—BNC (see **Section 2.3.1**).

You can also use the RPM—AUI to connect Ethernet devices using standard AUI cabling. Consider the following:

- The maximum transmission distance between a backbone transceiver equipped with an AUI connector and the RPM—AUI will vary. When you use an AUI cable to connect the RPM—AUI directly to a backbone transceiver, the maximum segment length is allowed. When you connect the RPM—AUI to a transceiver that has been cascaded from another transceiver, the maximum AUI segment length is reduced.

- According to Ethernet standards, the maximum distance from the transceiver AUI connector to the attached device (RPM—AUI) is 165 ft (50 m). The AUI segment’s maximum length is reduced in cascaded configurations.

### NOTE

**The maximum transmission distance is decreased by 20 ft (6 m) for every additional level of network transceiver device “dropped” or “cascaded” from the original backbone transceiver tap.**

The RPM–AUI connector supports standard IEEE signals, summarized below:

Pin	Function
1	Control In Circuit Shield
2	Control In Circuit A
3	Data Out Circuit A
4	Data In Circuit Shield
5	Data In Circuit A
6	Voltage Common
7	Control Out Circuit A
8	Control Out Circuit Shield (conductive shell)
9	Control In Circuit B
10	Data Out Circuit B
11	Data Out Circuit Shield
12	Data In Circuit B
13	Voltage Plus (+)
14	Voltage Shield
15	Control Out Circuit B
SHELL	Protective Ground

### NOTES

1. **Voltage Plus (pin 13) and Voltage Common (pin 6) use a single twisted pair in the AUI cable.**
2. **Pins 4, 8, 11, and 14 may be connected to pin 1.**

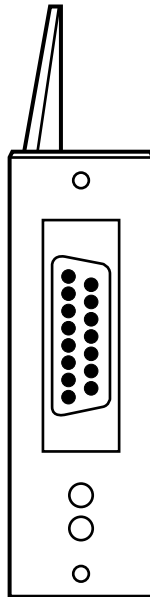

Figure 2-4. Repeater Port Module—AUI.



### 2.3.4 REPEATER PORT MODULE— FST (FIBER ST, TWIST-LOCK CONNECTOR)

The Repeater Port Module—FST is a multi-mode fiberoptic module equipped with a dual ST-type connector. It functions as an IEEE 802.3 full repeater to support 10BASE-FL and FOIRL network segments.

When used for 10BASE-FL segments, this module supports fiberoptic transmission distances of up to 6561 ft (2000 m). For FOIRL applications, it supports fiber segments of up to 3280 ft (1000 m).

The RPM—FST has a built-in fiber transceiver, so you don't need to use an external one.

The RPM has three LEDs: Partition (PART), Receive (RX), and LINK.

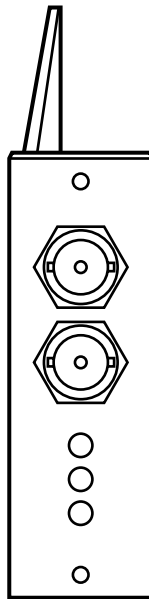

Figure 2-5. Repeater Port Module—FST.

## 2.4 Bridge Port Modules (BPMs)

Four different Bridge Port Modules are available: RJ-45 (10BASE-T and UTP), BNC (ThinNet or 10BASE2), AUI (10BASE5 or ThickNet), and ST (Ethernet multi-mode Fiber).

### 2.4.1 BRIDGE PORT MODULE—TP

The Bridge Port Module—TP has a single RJ-45 connector and supports Ethernet twisted-pair segments of any standard length. The RJ-45 connector is shielded to minimize emissions and connects to unshielded (UTP) twisted pair (STP) segments. The maximum segment distance for unshielded twisted pair is 325 ft (100 m).

The BPM—TP also has a Media Dependent Interface—Crossover

(MDI-X) slide switch for cascading, so you don't need a special twisted-pair crossover cable. For MDI-X switch details, see **Section 2.3.1**.

The BPM—TP will support 10BASE-T unshielded twisted-pair wiring (UTP) environments with maximum segment distances up to 325 ft (100 m). This module also has an internal transceiver. The BPM—TP has three LEDs: FWD-I, FWD-X, and LINK. The FWD-I LED blinks green to indicate that packets are being forwarded into the local segment connected to the MiniBridge. The FWD-X blinks green when packets are being forwarded OUT of the MiniBridge to the upstream network. The LINK LED lights green to indicate an operational segment link.

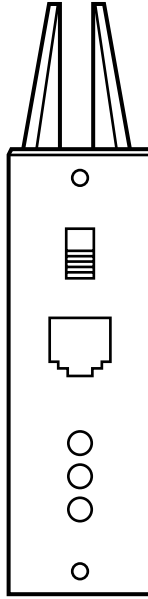
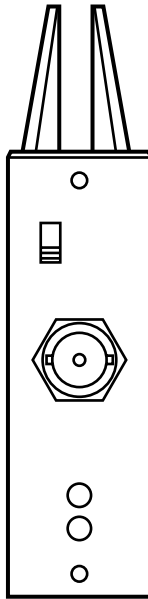

**Figure 2-6. Bridge Port Module—TP.**

### 2.4.2 BRIDGE PORT MODULE—BNC

The Bridge Port Module—BNC has a standard 10BASE2 coax connector. This BPM is self-learning and filters and forwards packets at full Ethernet wire speed. It is used for 10BASE2 ThinNet (BNC) connections and is designed to isolate the local segment (the users and devices connected to the Workgroup MiniBridge unit housing the BPM) from the connecting network (the users and devices connected through the BPM's media connector).

The BPM—BNC has a special switch-selectable internal termination function, so you don't need a "T" connector and a 50-ohm terminator. For switch details, see **Section 2.3.1**. The BPM—BNC module includes a FWD-I LED and a FWD-X LED, which are the same as those of the BPM—TP (see **Section 2.4.1**).



**Figure 2-7. Bridge Port Module—BNC.**

### 2.4.3 BRIDGE PORT MODULE—AUI

This module has a DB15 AUI female connector and a slide-lock. It is self-learning and filters and forwards packets at full Ethernet wire speed. It provides bridge isolation from a 10BASE5 (ThickNet) backbone or any AUI segments. You need to use a transceiver when connecting to a ThickNet segment. The BPM—AUI is also a “universal” Ethernet media interface, so you can use it with a variety of different mini-transceivers to provide connection to any media type.

The BPM—AUI has one FWD-I LED and one FWD-X LED, which are the same as those of the BPM—BNC (see **Section 2.4.1**).

The RPM—AUI connector supports standard IEEE signals, which are summarized in **Section 2.3.3**.

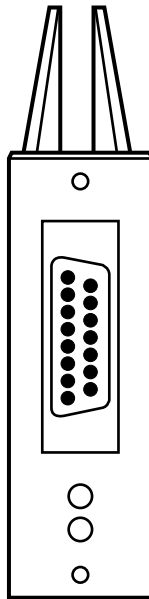

**Figure 2-8. Bridge Port Module—AUI.**

#### 2.4.4 BRIDGE PORT MODULE—FST

The Bridge Port Module—FST is a multi-mode fiberoptic local bridge module that has a dual ST-type connector. It is self-learning and filters and forwards packets at full Ethernet wire speed. When used for 10BASE-FL segments, this module supports fiberoptic transmission distances up to 6561 ft (2000 m). For FOIRL, it supports fiber segments of up to 3280 ft (1000 m). The BPM—FST includes a built-in transceiver, so it does not require an external transceiver. The BPM—FST has three status LEDs, which are the same as those of the BPM—TP (see Section 2.4.1).

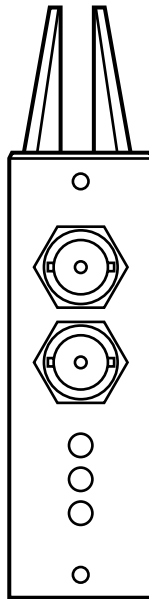

Figure 2-9. Bridge Port Module—FST.

### 2.5 Features

- Instantly frees up network bandwidth for increased performance—Once installed, the Workgroup MiniBridge frees up bandwidth in the workgroup by filtering out unneeded central network traffic, preventing it from causing congestion in the workgroup network segment. The performance impact on the network is the same as using a two-port switching hub.
- “Plug and play” installation and operation—The Workgroup MiniBridge learns the network addresses of the local workgroup network devices from the packets in the traffic, so there is no software setup required. As users or servers are added or changed, the unit learns the new network addresses and adapts automatically.
- Operation is transparent to software—The Workgroup MiniBridge operates as a transparent bridge, forwarding only packets that are not needed on the workgroup segment. Its operation will not affect any standard software applications or SNMP network-management platforms.
- Convenient compact enclosure allows for versatile installation—The compact size of the Workgroup MiniBridge allows it to be installed in virtually any location within reach of a standard AC wall outlet.
- Portable design makes hotspot analysis easy—The portable design of the Workgroup MiniBridge allows LAN managers to test for network hotspots and relocate the unit as traffic patterns change. By inserting the Workgroup MiniBridge into an existing network segment, temporary traffic bottlenecks can be easily alleviated.
- PMs (Port Modules) for all standard Ethernet media—Models are available for any network media type. PMs support all of the various IEEE 802.3 standards, including 10BASE-FL, FOIRL, 10BASE2, 10BASE5, and 10BASE-T.
- LEDs indicate the network status of each PM card—Each PM card is equipped with traffic activity and segment status LEDs for a visual display of dynamic traffic activity and patterns.

## 2.6 Applications

The Workgroup MiniBridge increases local bandwidth by segmenting the workgroup from the rest of the network. To effectively use the Workgroup Bridge, install it in an environment well suited to such an application. For the Workgroup MiniBridge to produce the desired throughput increase, the segmented workgroup should have local servers and printers that are used by the users in the workgroup, which create local traffic. A segmented workgroup without its own server may not be well suited for a Workgroup MiniBridge, since all traffic between workgroup nodes and the server will pass through the bridge, yielding a high forwarding percentage and little benefit. A poorly placed bridge produces very little performance increase for the segmented workgroup.

Figures 2-10 and 2-11 illustrate a workgroup that benefits from the installation of a Workgroup MiniBridge. This configuration is typical of departmental workgroups; it has its own server and printer, and most communication is among user nodes and the server. Although the workgroup is fairly self-sufficient, it has been slowed down by unnecessary traffic from the rest of the network. By simply placing a Workgroup MiniBridge in the workgroup's uplink connection, local traffic is reduced, and workgroup bandwidth is increased.



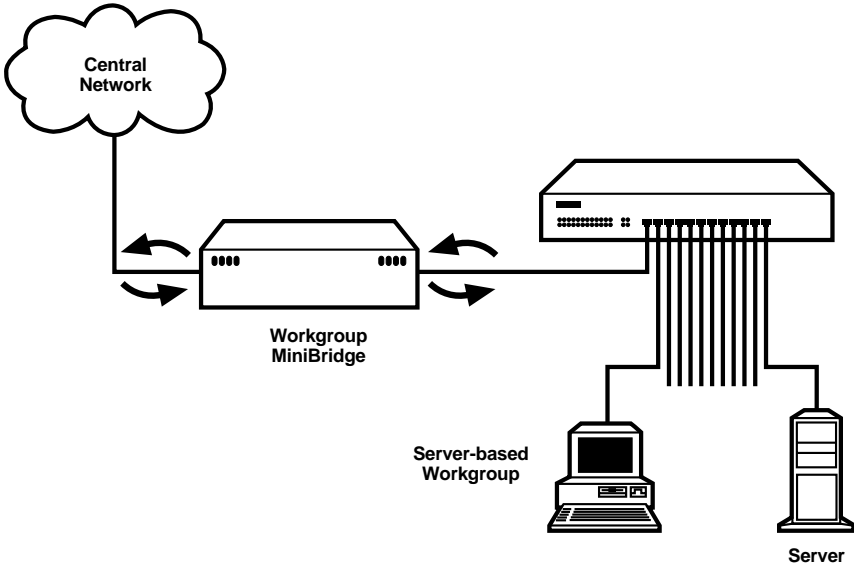

**Figure 2-10. Bridge Isolation of a Cascaded Workgroup.**

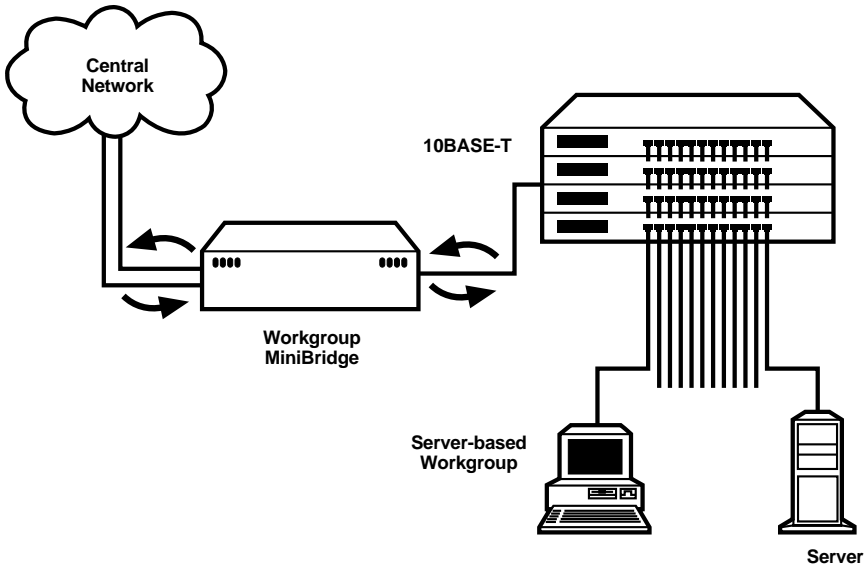

**Figure 2-11. Workgroup Bridge Isolation, Stacked Hubs.**

The example above shows how the Workgroup MiniBridge can easily be installed in the 10BASE-T uplink connection of a workgroup. With other standard Ethernet media, installation is just as simple, and does not require transceivers. You can even bridge two segments of different Ethernet media types.

## WORKGROUP MINIBRIDGE

Consider the ThinNet (BNC) network shown in **Figure 2-12**. This network consists of several workgroups tied together by a central BNC backbone. As in the previous example, most of the workgroups have their own server, and communicate mostly among themselves. In this example, the two workgroups at the left end of the backbone communicate quite

frequently with one other. To increase their local bandwidth, a Workgroup MiniBridge is inserted in-line into the backbone. The installation is quick and simple, and you don't need "T" connectors, since each of the Workgroup MiniBridge's ports has an internal termination switch (see **Section 2.3.1**).

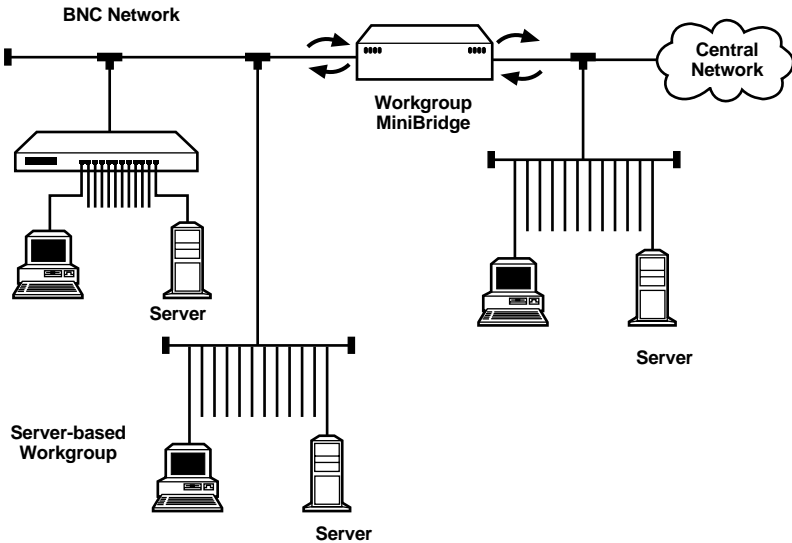

**Figure 2-12.** Workgroup MiniBridge Isolation on a ThinNet Network.

As shown in **Figure 2-13**, not all workgroups are small, and some workgroups are managed by SNMP and other network management protocols. The Workgroup MiniBridge can store up to 256 network addresses in its address

table, so bridge-isolated workgroups can have up to 256 attached nodes (see **Section 4.1**). The Workgroup MiniBridge is transparent to all software, including SNMP and network management systems.

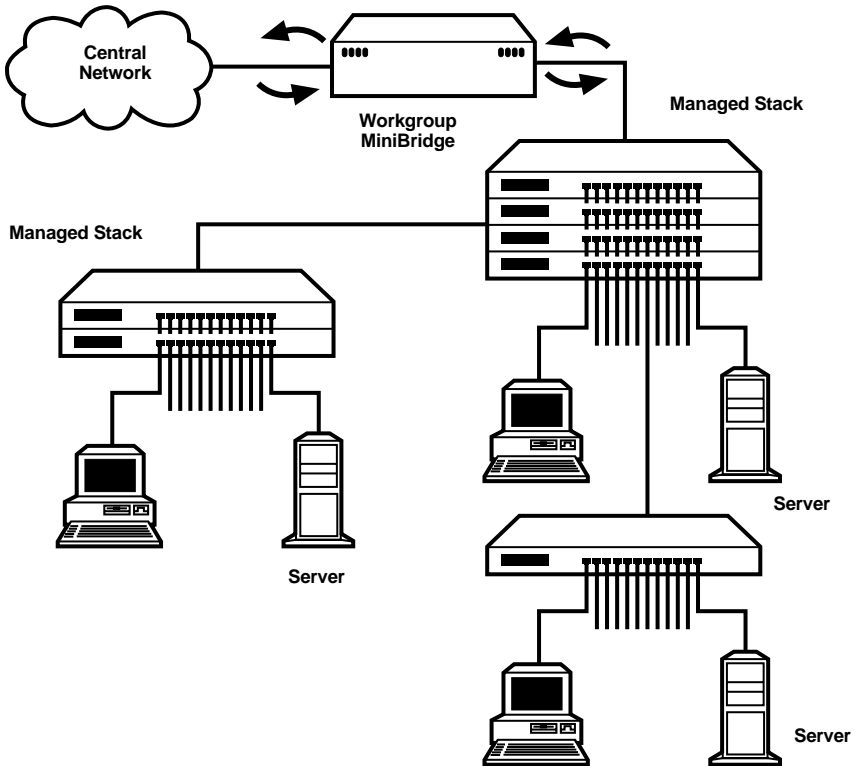

**Figure 2-13. Bridge Isolation of a Large, Managed Workgroup.**

## 3. Installation

### 3.1 Locating the Workgroup MiniBridge

The location of the Workgroup MiniBridge depends on the physical layout of the network and the workgroup to be bridge-isolated. The compact size of the unit allows it to be shelf- or wall-mounted.

Locate an AC receptacle that is within six feet (2 meters) of the intended Workgroup MiniBridge site. The rugged metal case of the Workgroup MiniBridge will normally protect it from accidental damage in a lab or workplace setting. Keep an open area around the unit so that convection cooling can occur while the unit is operating.

#### 3.1.1 TABLE-TOP OR SHELF-MOUNTING

You can easily mount the Workgroup MiniBridge on a table-top or any suitable horizontal surface. It has four rubber feet to provide stability without scratching finished surfaces.

#### 3.1.2 WALL (OR VERTICAL SURFACE) MOUNTING

Each Workgroup MiniBridge is shipped with two mounting brackets and screws let you mount the unit in nearly any desired position. The brackets attach to two opposite corners on the unit, through the round hole of the bracket. When properly attached, the brackets will extend slightly below the base of the unit to allow clearance for the rubber feet.

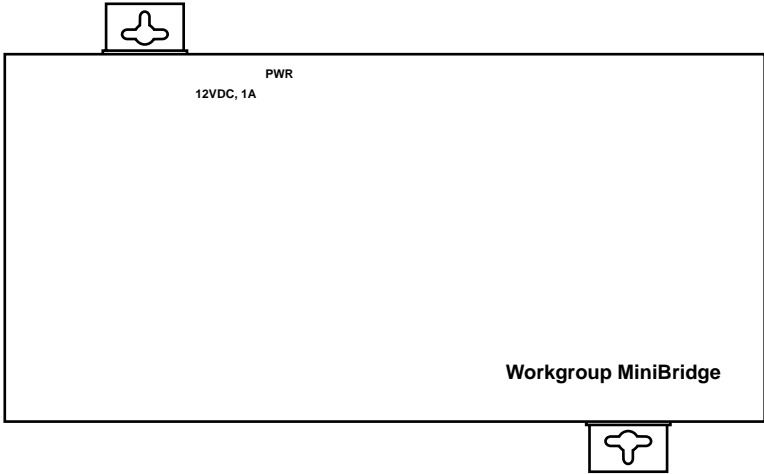

**Figure 3-1. Top View—Workgroup MiniBridge with Mounting Brackets.**

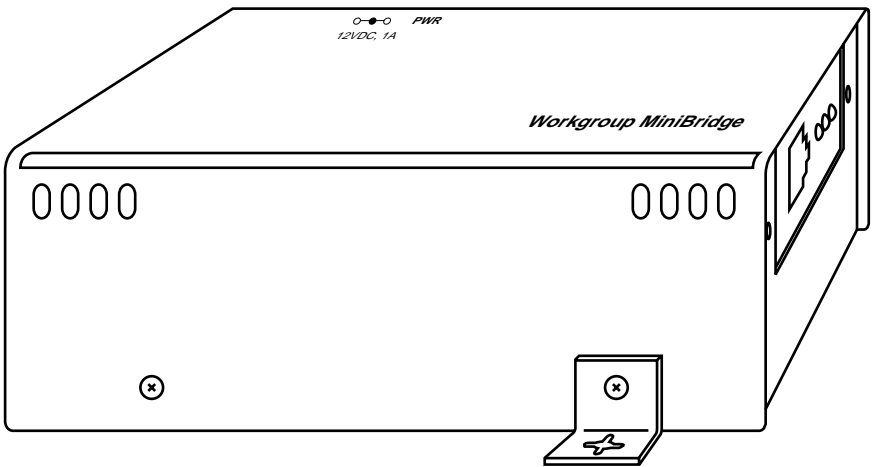

**Figure 3-2. Proper Installation of Mounting Bracket.**

You may also use a piece of Velcro® mounting tape (included) to secure your Workgroup MiniBridge to a smooth vertical surface. Stick one side of the Velcro to the bottom of the Workgroup MiniBridge between the rubber feet. Stick the other side of the Velcro to the smooth vertical surface. This lets you mount the Workgroup Bridge on a filing cabinet, file server, or similar location where it is not convenient to mount it with brackets and screws.

### 3.1.3 DIRECTION OF THE WORKGROUP MINIBRIDGE

Unlike a repeater, the Workgroup MiniBridge is a unidirectional device. Keep this in mind when inserting the unit into a network segment.

The internal BPM of the Workgroup MiniBridge keeps unneeded traffic off of the workgroup segment. Connect the BPM port to the upstream network and connect the RPM port to the workgroup segment.

When factory-configured, the BPM port is on the left end of the Workgroup MiniBridge, and the RPM unit is on the right end. The left end of the MiniBridge is labeled “Upstream port (BPM),” and the right end of the unit is labeled “Workgroup port (RPM).” To verify that the port labels are correct, check the LEDs. A BPM has LEDs labeled “X FWD” and “I FWD” to monitor the operation of the internal bridge (see **Section 2.4**). An RPM does not have “FWD” LEDs, but does have other LEDs (see **Section 2.3**).

For more details on the internal operation of the Workgroup MiniBridge, see **Section 4.1**.

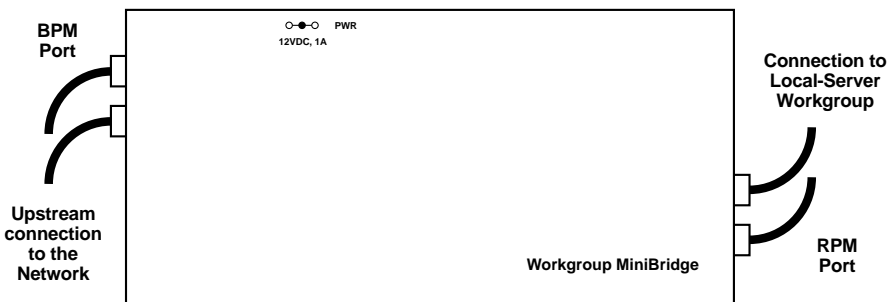

**Figure 3-3. Proper Connections for the Workgroup MiniBridge.**

### **3.1.4 INSTALLATION NOTES FOR THE WORKGROUP MiniBRIDGE AUI (LB9901A-AUI AND LB9901AE-AUI) AND THE WORKGROUP MiniBRIDGE AUI/FIBER (LB9901A-AST AND LB9901AE-AST)**

Installing the AUI and AST versions of the Workgroup MiniBridge requires two additional considerations that are not applicable to other models of the MiniBridge.

1. The AUI ports of the MiniBridge can be used as configurable media ports, because mini-transceivers can be attached to them. Each port can supply power to an attached mini-transceiver, so you can use any standard mini-transceiver to connect its media type. This may be useful if the MiniBridge is frequently moved or is used with different media types.
2. When connecting the AUI ports to AUI cable, all AUI connectors must be female (with slide locks). This lets you directly connect an AUI drop cable with a male connector. Be sure the AUI cables you use have a DB15 male connector on the ends you will connect to the ports on the MiniBridge.

## **3.2 Connecting Ethernet Media**

You can configure the Workgroup MiniBridge to meet any Ethernet media requirements, using the Port Modules (PMs). The various media types supported along with the corresponding IEEE 802.3 standards and connector types are shown in **Table 3-1**.



**Table 3-1. Media Types Supported.**

<b>Media</b>	<b>IEEE Standard</b>	<b>Connector</b>	<b>PM type</b>
ThinNet	10BASE2	BNC	RPM-BNC, BPM-BNC
ThickNet	10BASE5	AUI (female)	RPM-AUI, BPM-AUI
Twisted Pair	10BASE-T	RJ-45	RPM-TP, BPM-TP
Fiber (multi-mode)	FOIRL or 10BASE-FL	ST	RPM-FST, BPM-FST

### **3.2.1 CONNECTING TWISTED PAIR (RJ-45, SHIELDED OR UNSHIELDED)**

The following procedure describes how to connect a 10BASE-T unshielded twisted-pair segment to the RJ-45 port on the RPM—TP or the BPM—TP.

1. Using standard 10BASE-T media, insert either end of the cable with an RJ-45 plug into the RJ-45 connector of the PM—TP.
2. Connect the other end of the cable to the corresponding device.
3. Ensure proper connectivity via the LINK LED. When the unit is powered and is properly connected, the LINK LED will light. If the LINK LED is not lit, change the setting of the uplink switch. If this does not help, make sure that the cable is connected and is not defective.

**NOTE**

The uplink slide switch accommodates repeater-to-repeater connections without special cross-over connectors.

When installing a Workgroup MiniBridge RJ-45 (LB9901A-RJ and LB9901AE-RJ), the uplink switches of both connectors should have the same setting (both left or both right). When installing a Workgroup MiniBridge TP/Fiber (LB9901A-TST and LB9901AE-TST), set the uplink switch to DOWN (or RIGHT) position, depending on your network configuration (see Step 3 on page 34).

**3.2.2 CONNECTING THINNET 10BASE2 (BNC)**

Connect the ThinNet coax cable to the BNC connector on the RPM—BNC or BPM—BNC card. The PM—BNC has an internal termination switch on the front of the card (see **Section 4.1**), so you don't need to use a "T" connector when the BNC cable ends at the connection to this PM. Some applications, however, may require a "T" connector, used as a tap, to let the 10BASE2 coax segment continue on past the PM—BNC connection.

### 3.2.3 CONNECTING THICKNET 10BASE5 (AUI)

Follow the steps below to attach a new or existing 10BASE5 ThickNet drop cable directly to the AUI connector on the RPM—AUI or BPM—AUI port.

1. Plug the male end of the cable into the female AUI connector on the PM—AUI card.
2. Engage the AUI connector's slide lock to make sure the connection is secure.
3. Connect the opposite end of the cable into a network AUI port. (This could be a network backbone transceiver, a hub or fanout with an AUI backbone port, or an AUI module in a concentrator.)

You may also connect the PM—AUI card to other Ethernet devices using standard AUI cabling. Consider the AUI segment length to the attached device, including any cascading (see **Chapter 2** for detailed information on the PM—AUI card, connector pins, and cable lengths).

### 3.2.4 CONNECTING FIBEROPTIC 10BASE-FL AND FOIRL (ST TYPE, "TWIST-LOCK")

The following procedure applies to FOIRL and 10BASE-FL applications using an RPM—ST or BPM—ST card with ST type fiber connectors. The primary difference between FOIRL and 10BASE-FL for users is the maximum distance allowed. 10BASE-FL is used for a fiber segment of length of up to 6561 ft (2000 m), while FOIRL is used for fiber segments of up to 3280 ft (1000 m).

1. Before connecting the fiberoptic cable, remove the protective dust caps from the tips of the connectors on the PM—ST. Save these dust caps for future use.
2. Wipe clean the ends of the dual connectors with a soft cloth or lint-free lens tissue dampened in alcohol. Make sure the connectors are clean before connecting.

**NOTE**

**One strand of the duplex fiberoptic cable is coded using color bands at regular intervals; you must use the color-coded strand on the associated ports at each end of the fiberoptic segment.**

3. Connect the transmit (TX) port (light colored post) on the PM—FST to the receive (RX) port of the remote device. Begin with the color-coded strand of the cable for the first TX-to-RX connection.
4. Connect the receive (RX) port (dark colored post) on the PM—FST to the transmit (TX) port of the remote device. Use the non-color-coded fiber strand for this.
5. The LINK LED on the front of the PM—FST will light when a proper connection is made at both ends (and when power is ON in the unit). If the LINK LED is not lit after connecting the cables, polarity of the cable is wrong. Swap the fiber cables at the Port Module connector to remedy this situation.

## 3.3 Replacing PM Cards

The Workgroup MiniBridge is factory-configured with one RPM and one BPM. As your media requirements change, a trained technician can replace one or both of these PM cards. Follow the steps listed below.

### CAUTION

**Unplug the power cord from the chassis before removing or replacing a PM card. If you don't unplug the unit, it could be damaged.**

1. Remove the four screws located on the sides of the unit (two per side). Lift the chassis cover off the chassis base to expose the interior of the unit.

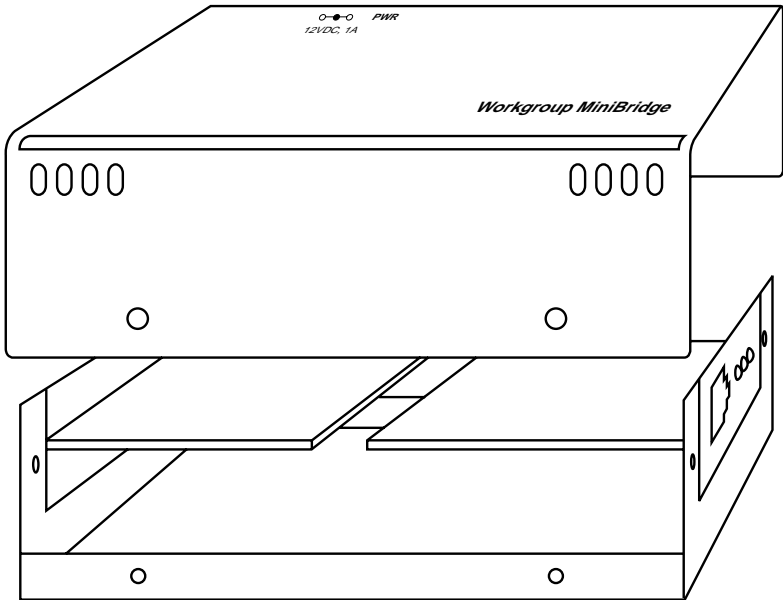
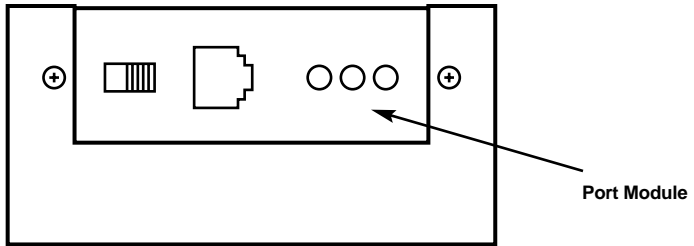

Figure 3-4. Removing the Chassis Cover.

2. On either end of the unit there are two retaining screws for the PM card slot to secure the individual PM modules. Remove the appropriate screws for the Port Module you will replace.



**Figure 3-5. Removing the PM Retaining Screws.**

3. Remove the desired PM card by gently pulling it away from the connector socket and parallel to the main board. When the card is clear of the socket, lift it away from the unit.

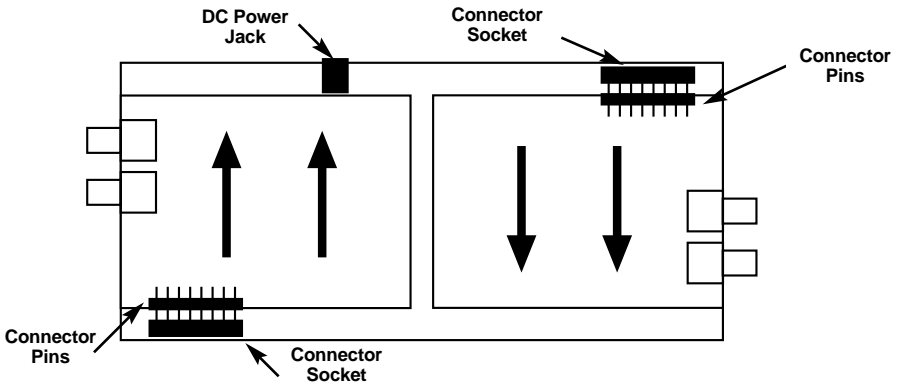

**Figure 3-6. Removing the PM Card.**

4. Hold the card parallel to the main board and align the connector pins on the PM card with the connector socket inside the unit. The PM card will slide easily into the connector socket. Slowly and firmly push the card into position. Secure the PM using the two retaining screws.

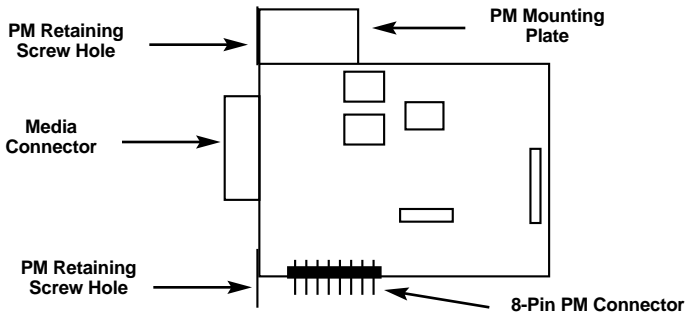

**Figure 3-7. Side View of the PM Card.**

5. Replace the cover on the chassis and secure with the four screws.

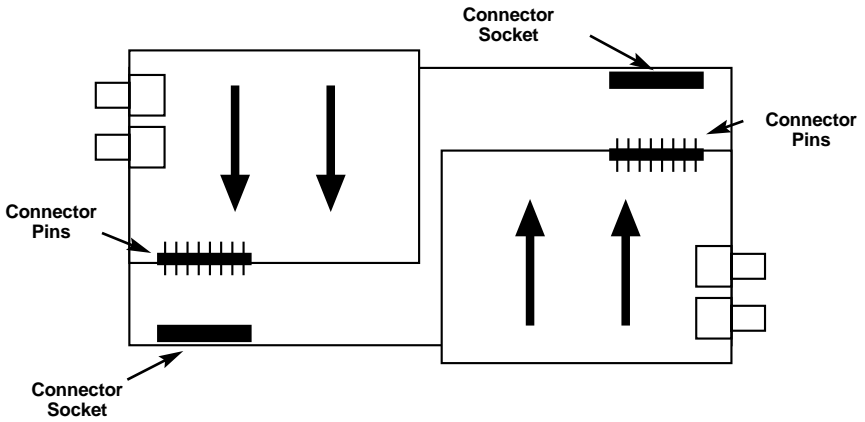

**Figure 3-8. Inserting the PM Cards.**



## 4. Operation

The Workgroup MiniBridge consists of one Repeater Port Module and one Bridge Port Module housed in a compact metal enclosure. When properly installed in a network, the RPM portion of the unit will behave as a repeater and forward all packets it receives in both directions. The BPM portion of the unit will make filter/forward decisions on a per-packet basis to reduce traffic across the bridged Ethernet segments.

The function of the BPM is described here.

1. Bridge Functions—Each BPM card contains a special compact local bridge module that filters and forwards packets at full Ethernet wire speed. These microbridges are self-learning and have small (256-user) address tables.

The MiniBridge makes packet filter/forward decisions based on whether the packet source is internal (originates within the Hub/Stack segment) or external (originates from upstream on the attached “central network” segment). If the packet’s source is local/internal, it is forwarded to the outside only if the destination address is not in the address table. **Figure 4-1** shows an internal packet being forwarded to the external segment.

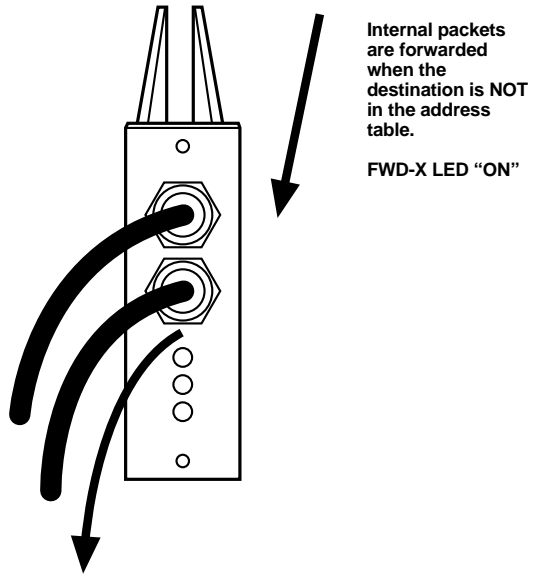

**Figure 4-1. Internal Packet Forwarded.**

Figure 4-2 shows the case where an internal packet is filtered. When the packet's source is local/internal, it is contained in the inside of the BPM when the destination address is in the address table.

Internal packets are filtered when the destination is IN the address table.

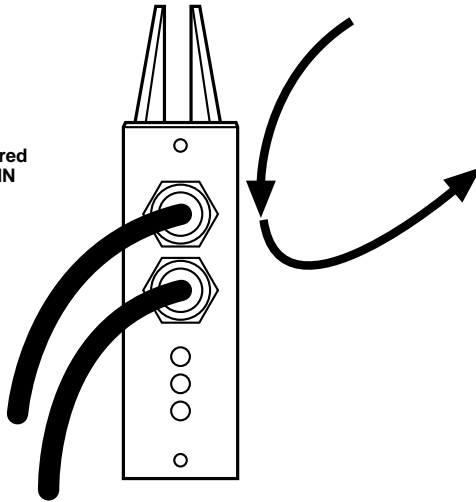
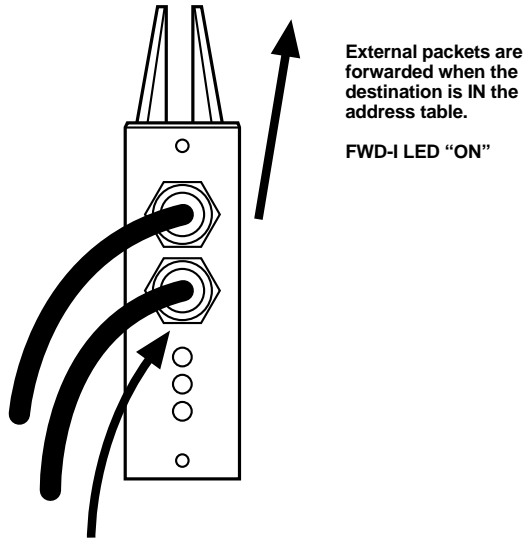

Figure 4-2. Internal Packets Filtered.

The filter handling and forward handling of external packets are shown in **Figures 4-3** and **4-4**, respectively. When an internal packet's source address is not already in the address table, it is written there. This happens when a node first sends a packet upon bridge initialization.



**Figure 4-3. External Packet Forwarded.**

## NOTE

The address table learns only internal addresses, i.e., those of the workgroup nodes and servers connected via the RPM connector of the Workgroup MiniBridge, a number typically well under the 256 table-addresses size. If the table becomes full, the BPM will clear all entries in the table by reinitializing itself.

When an external packet's source address is in the address table, it is purged. This can occur if a node has physically moved to a different location.

External packets are filtered when the destination is NOT in the address table.

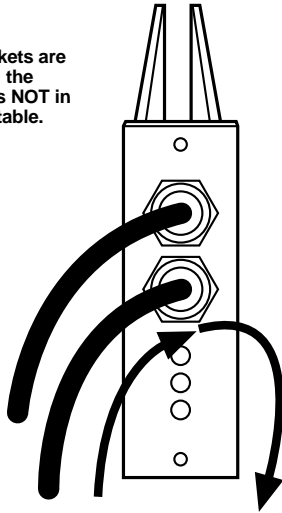

Figure 4-4. External Packet Filtered.

A summary of the filtering, forwarding, and address-table-maintenance operations performed by the BPMs is shown in **Table 4-1**.

**Table 4-1. BPM Function.**

<b>Packet Source</b>	<b>Source Address</b>	<b>Destination Address</b>	<b>Address Table Maintenance</b>	<b>Filter/Forward Action</b>
Internal	Not in table	Not in table	Add source to table	Forward
Internal	Not in table	In table	Add source to table	Filter
Internal	In table	Not in table	Nothing	Forward
Internal	In table	In table	Nothing	Filter
External	Not in table	Not in table	Nothing	Filter
External	Not in table	In table	Nothing	Forward
External	In table	Not in table	Purge source from table	Filter
External	In table	In table	Purge source from table	Forward

2. Throughput increase—By using a Workgroup MiniBridge to bridge-isolate a workgroup segment that has significant local traffic, you can substantially increase overall network throughput. For example, a segment containing a group of workstations and servers may have heavy local traffic, but only a small amount of traffic that is directed outside the segment. A Workgroup MiniBridge connecting this segment to the rest of the network, as shown in

**Figure 4-5**, will keep the local segment traffic bridge-isolated from the rest of the network, thus increasing the effective bandwidth on both the local segment and the rest of the network.

Inserting a Workgroup MiniBridge into a network segments the network into two separate bridge-isolated traffic domains (just as a two-port switching hub could segment a network).

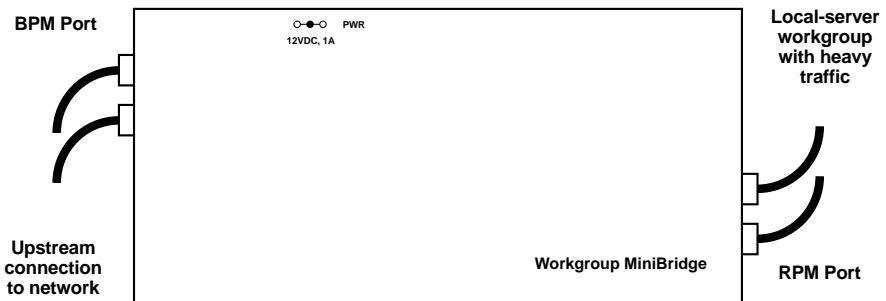

**Figure 4-5. Bridge-isolation via the Workgroup MiniBridge.**

3. Software Transparency—The Workgroup MiniBridge is transparent to both the user and the application software, including SNMP management software.

## NOTE

**An NMS located upstream will see an SNMP agent located across the Workgroup Bridge in the local segment normally, in other words, SNMP packets will be forwarded normally in both directions by the MiniBridge.**

4. LINK and Traffic Status—The BPM—TP and BPM—FST link indicate link integrity with an LED, which is normally lit. When the LINK LED is not lit, there is a broken cable or loss of power somewhere on the segment. All BPMs have FWD-I and FWD-X status LEDs. The FWD-I LED flashes when packets are forwarded into the local segment. The FWD-X LED flashes when packets are forwarded out of the local segment.
5. Self-Test Diagnostics—The Workgroup MiniBridge requires approximately 15 seconds to run a self-test upon power on before bridging services are available.
6. No Benefit if No Local Traffic—The Workgroup MiniBridge can improve network performance only if there is local traffic to be filtered from the upstream segment, and vice versa. When there is a network configured so that essentially all packets are forwarded by the MiniBridge, using the MiniBridge will result in no performance improvement.

As an example, consider a network configured with dispersed workgroup hubs connected to groups of local users, but with all servers connected at a central concentrator. In this example, the normal network traffic will be between users and the central servers (unless the users have a peer-to-peer network system). Inserting a Workgroup MiniBridge will not reduce traffic significantly because practically all of the packets must be forwarded so they can travel up to the servers at the central concentrator.

Configuring the network by distributing some or all of the printers, file servers, application servers, and communications servers out with the local workgroup users—the typical network topology—will result in normal benefits from using the Workgroup MiniBridge to segment the network into multiple traffic domains.

## 4.2 PM LEDs

For information on the status LEDs of a particular Port Module, refer to the PM card's description in **Chapter 2**.



## 5. Troubleshooting

If problems develop during installation or operation, follow the suggestions in this chapter before contacting technical support for assistance.

### 5.1 Before Calling for Technical Support

1. Check to make sure that the various other components of the network are operable.
2. Check the cables and connectors to ensure that they have been properly connected and the cables or wires have not been crimped or in some way impaired during installation. (Most network downtime can be attributed to wiring and connector problems.)
3. Make sure that the AC power cord is plugged into a functioning electrical outlet, and that the cord is properly plugged into the Workgroup MiniBridge.
4. If the problem is isolated to a network device other than the MiniBridge, replace the problem device with a known good device.
5. If the problem continues, contact technical support.

### 5.2 Contacting Technical Support

Please be prepared to provide the following information.

1. A complete description of the problem, including:
  - The nature and duration of the problem;
  - Situations when the problem occurs;
  - The components involved in the problem;
  - Any particular application that appears to trigger the problem.
2. The model number of your Workgroup MiniBridge (look for a sticker on the bottom). Include when you purchased the MiniBridge from your supplier.
3. A record of changes that have been made to your network before the problem occurred.



© Copyright 1995. Black Box Corporation. All rights reserved.

---

1000 Park Drive • Lawrence, PA 15055-1018 • 724-746-5500 • Fax 724-746-0746