



Feb 2002

LB8405A	LB8408A
LB9002A-SC-R2	LB9002A-ST-R2
LB9006A-SC	LB9006A-ST
LB9007A-SC-R2	LB9007A-ST-R2
LB9008A-FO	LB9012A-R2
LB9017A-R2	LB9019A
LB9020A	LB9021A
LB9022A	LB9024A
LB9108A	

Express Ethernet Switches

CUSTOMER
SUPPORT
INFORMATION

Order toll-free in the U.S. 24 hours, 7 A.M. Monday to midnight Friday: **877-877-BBOX**
FREE technical support, 24 hours a day, 7 days a week: Call **724-746-5500** or fax **724-746-0746**
Mail order: **Black Box Corporation**, 1000 Park Drive, Lawrence, PA 15055-1018
Web site: www.blackbox.com • E-mail: info@blackbox.com

FEDERAL COMMUNICATIONS COMMISSION AND
CANADIAN DEPARTMENT OF COMMUNICATIONS
RADIO FREQUENCY INTERFERENCE STATEMENT

Class B Digital Device. This equipment has been tested and found to comply with the limits for a Class B computing device pursuant to Part 15 of the FCC Rules. These limits are designed to provide reasonable protection against harmful interference in a residential installation. However, there is no guarantee that interference will not occur in a particular installation. This equipment generates, uses, and can radiate radio frequency energy, and, if not installed and used in accordance with the instructions, may cause harmful interference to radio communications. If this equipment does cause harmful interference to radio or telephone reception, which can be determined by turning the equipment off and on, the user is encouraged to try to correct the interference by one of the following measures:

- Reorient or relocate the receiving antenna.
- Increase the separation between the equipment and receiver.
- Connect the equipment into an outlet on a circuit different from that to which the receiver is connected.
- Consult an experienced radio/TV technician for help.

Caution:

Changes or modifications not expressly approved by the party responsible for compliance could void the user's authority to operate the equipment.

To meet FCC requirements, shielded cables and power cords are required to connect this device to a personal computer or other Class B certified device.

This digital apparatus does not exceed the Class B limits for radio noise emission from digital apparatus set out in the Radio Interference Regulation of the Canadian Department of Communications.

Le présent appareil numérique n'émet pas de bruits radioélectriques dépassant les limites applicables aux appareils numériques de la classe B prescrites dans le Règlement sur le brouillage radioélectrique publié par le ministère des Communications du Canada.

Normas Oficiales Mexicanas (NOM)
INSTRUCCIONES DE SEGURIDAD

1. Todas las instrucciones de seguridad y operación deberán ser leídas antes de que el aparato eléctrico sea operado.
2. Las instrucciones de seguridad y operación deberán ser guardadas para referencia futura.
3. Todas las advertencias en el aparato eléctrico y en sus instrucciones de operación deben ser respetadas.
4. Todas las instrucciones de operación y uso deben ser seguidas.
5. El aparato eléctrico no deberá ser usado cerca del agua—por ejemplo, cerca de la tina de baño, lavabo, sótano mojado o cerca de una alberca, etc.
6. El aparato eléctrico debe ser usado únicamente con carritos o pedestales que sean recomendados por el fabricante.
7. El aparato eléctrico debe ser montado a la pared o al techo sólo como sea recomendado por el fabricante.
8. Servicio—El usuario no debe intentar dar servicio al equipo eléctrico más allá de lo descrito en las instrucciones de operación. Todo otro servicio deberá ser referido a personal de servicio calificado.
9. El aparato eléctrico debe ser situado de tal manera que su posición no interfiera su uso. La colocación del aparato eléctrico sobre una cama, sofá, alfombra o superficie similar puede bloquear la ventilación, no se debe colocar en libreros o gabinetes que impidan el flujo de aire por los orificios de ventilación.

10. El equipo eléctrico deber ser situado fuera del alcance de fuentes de calor como radiadores, registros de calor, estufas u otros aparatos (incluyendo amplificadores) que producen calor.
11. El aparato eléctrico deberá ser conectado a una fuente de poder sólo del tipo descrito en el instructivo de operación, o como se indique en el aparato.
12. Precaución debe ser tomada de tal manera que la tierra física y la polarización del equipo no sea eliminada.
13. Los cables de la fuente de poder deben ser guiados de tal manera que no sean pisados ni pellizcados por objetos colocados sobre o contra ellos, poniendo particular atención a los contactos y receptáculos donde salen del aparato.
14. El equipo eléctrico debe ser limpiado únicamente de acuerdo a las recomendaciones del fabricante.
15. En caso de existir, una antena externa deberá ser localizada lejos de las líneas de energía.
16. El cable de corriente deberá ser desconectado del cuando el equipo no sea usado por un largo periodo de tiempo.
17. Cuidado debe ser tomado de tal manera que objetos líquidos no sean derramados sobre la cubierta u orificios de ventilación.
18. Servicio por personal calificado deberá ser provisto cuando:
 - A: El cable de poder o el contacto ha sido dañado; u
 - B: Objetos han caído o líquido ha sido derramado dentro del aparato; o
 - C: El aparato ha sido expuesto a la lluvia; o
 - D: El aparato parece no operar normalmente o muestra un cambio en su desempeño; o
 - E: El aparato ha sido tirado o su cubierta ha sido dañada.

About This Manual

This manual describes the Black Box Express Ethernet Switch in these basic sections:

- Product Features
- Installation
- Trouble-shooting
- Glossary of Terms

Product Features

This section examines the key features, the physical features, and the product specifications of each model.

Installation

This section leads with a Quick Tip, and continues with a detailed description of Connecting to Power and Connecting to Your Network with the two types of cable: copper-based and fiber-optic. The section concludes with instructions on using the Uplink Function.

Trouble-shooting

This guide leads you through trouble-shooting the most common networking problems.

Glossary

A brief glossary defines the terms used in this manual.

This manual services the following Express Ethernet Switches:

SIZE	PART NUMBER	PORT COUNT
PALM	LB8405A	5 port TX
PALM	LB8408A	8 port TX
COMPACT	LB9002A-SC/ST	1 port TX, 1 port FX
COMPACT	LB9108A	8 port TX
RACKMOUNT	LB9007A-SC/ST-R2	7 port TX 1 port FX
RACKMOUNT	LB9006A-SC/ST	2 port TX 6 port FX
RACKMOUNT	LB9021A	6 port TX 2 port FX (SC)
RACKMOUNT	LB9022A	6 port TX 2 port FX (ST)
RACKMOUNT	LB9008A-FO	8 port FX
RACKMOUNT	LB9012A-R2	12 port TX
RACKMOUNT	LB9019A	16 port TX
RACKMOUNT	LB9020A	24 port TX
RACKMOUNT	LB9017A-R2	16 port TX with module slot
RACKMOUNT	LB9024A	24 port TX with module slot

Table of Contents

Feb 2002.....	1
.....	1
.....	1
About This Manual.....	4
Product Features.....	4
Installation.....	4
Trouble-shooting.....	4
Glossary.....	4
Product Features.....	7
Key Features.....	7
Physical Features.....	8
Illustrated Palm-Size Switches.....	9
LB8405A.....	9
LB8408A.....	9
Illustrated Compact-Size Switches.....	12
LB9002A-SC-R2/LB9002A-ST-R2.....	12
LB9108A.....	13
Illustrated Rackmount-Size Switches.....	15
LB9007A-ST-R2/LB9007A-SC-R2.....	15
LB9021A & LB9022A.....	17
LB9006A-ST or LB9006A-SC.....	17
LB9008A-FO.....	17
LB9012A-R2.....	19
LB9019A.....	21
LB9020A.....	21
LB9017A-R2.....	21
LB9024A.....	22
Special features for LB9007A-ST-R2, LB9007A-SC-R2, LB9012A-R2, LB9017A & LB9024A.....	23
Setting up Console Port Connection.....	23
VLAN and Speed/Duplex port setting for LB9007A-ST-R2, LB9007A-SC-R2 & LB9012A-R2.....	24
Establishing a VLAN for LB9007A-ST-R2, LB9007A-SC-R2 & LB9012A.....	25
Configure Port Settings.....	26
VLAN and Speed/Duplex port setting for LB9017A-R2, LB9024A.....	28
Establishing a VLAN.....	28
Configuring Ports.....	30
Fiber Module Installation.....	31
Product Specifications.....	31
Installation.....	33
Quick Tip.....	33
Connecting to Power.....	33
Connecting to Your Network.....	33
Copper-based cabling.....	33
Fiber-optic cabling.....	33
Uplink or MDI Function.....	34
No Power to the Switch.....	35
No Connectivity to the Data Terminal Equipment.....	35
No Connectivity to Certain Nodes on the Network.....	35
Transmission Problems.....	36
Trademarks.....	37
Glossary.....	37

Product Features

This section addresses:

- Key Features
- Physical Features (including LEDs)
- Product Specification

Key Features

- Auto-negotiation for speed and duplex on every TX port
- Plug & play
- True non-blocking architecture
- Full wire-speed forwarding
- Store-and-forward switching mechanism
- Runt and CRC filtering eliminate erroneous packets to optimize network bandwidth
- Back pressure for half-duplex
- IEEE 802.3x flow control for full-duplex
- MAC address filtering and relearning that automatically adjusts to the network configuration
- Comprehensive array of LED indicators that communicate the status of the switch and trouble-shooting information
- Designed in compliance with 10BASE-T, IEEE802.3u, 100BASE-TX, and 100BASE-FX standards
- Full compatibility with standard Ethernet applications, internetworking systems, and client-side adapters to minimize migration cost

Physical Features

- **AC Input:** 100-240VAC, 47-63Hz internal universal power supply
- **Input Fuse:** 2A
- **Power Consumption:** 11W
- **Operating Temperature:** 0 C- 40 C (32 F- 104 F)
- **Storage Temperature:** -25 C- 70 C (-13 F-158 F)
- **Humidity:** 10%-90% non-condensing
- **Emission Compliance:** FCC part 15 class A, CE Mark, VCCI Class A
- **Safety:** UL
- **Dimensions:** W440mm x D205mm x H45mm (17.3" x 8" x 1.8") Standard 19" Rack Mount Size
- **Net weight:** 2.5kg(5.5lb)

Illustrated Palm-Size Switches

This group includes two models: LB8405A and LB8408A

LB8405A

Figure

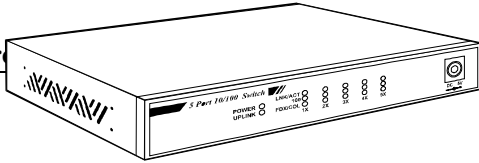

LB8408A

Figure

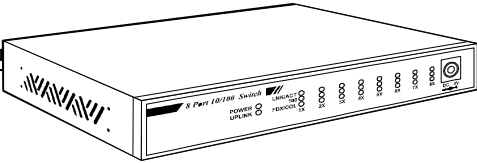

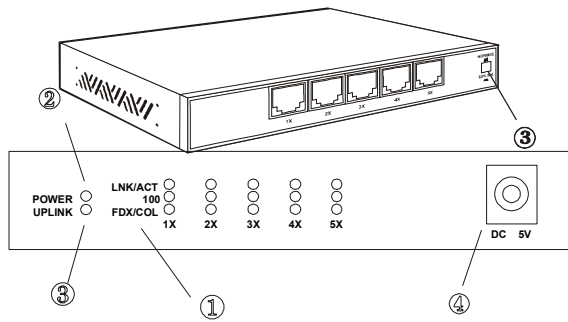

Figure 3: LED and function features for LB8405A and LB8408A

1 Port Status

A set of three LEDs conveys the status of each port as detailed on the following chart.

Table 1: Port status LEDs for palm-size, 5-port LB8405A or 8-port LB8408A

LED	State	Indication
LNK/ACT (link/activity)	Steady	The port has established a valid network connection
	Flashing	The port is transmitting or receiving data
100	Steady	The port has established a valid 100 Mbps connection
	Off	The port has established a valid 10 Mbps network connection
FDX/COL (full-duplex/collision)	Steady	The connection is in full-duplex mode
	Flashing	Collision occurred in the 10/100 domain*
	Off	The connection is in half-duplex mode

*Collision will only occur on the half-duplex mode of transmission between two devices.

2 Power

This LED illuminates upon connection to the power adapter if the switch is turned on.

3 Uplink

The indicator light is located on the front of the unit, while the activation button is on the back of the unit along with the ports.

④ Power Adapter

Connect the supplied AC adapter to the receptacle on the back of the switch, and then plug the cord into a 110 AC outlet.

Illustrated Compact-Size Switches

The front panel of the compact switch has two or eight ports and LED indicators to provide instant feedback on the status of the switch. This group includes LB9002A-SC/ST, and LB9108A.

LB9002A-SC-R2/LB9002A-ST-R2

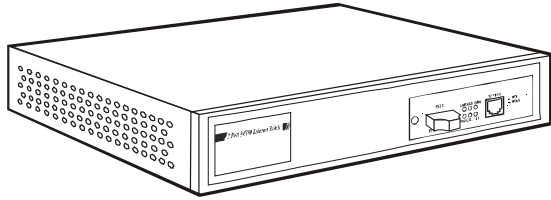

Figure 4: Compact-size, 2-port with fiber LB9002A-SC-R2 (also available in ST)

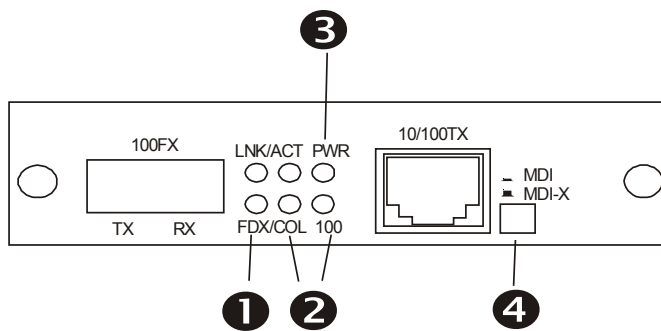

Figure 5: LED and functions of the two-port switch (LB9002A-SC-R2 & LB9002A-ST-R2)

❶ Port Status for the FX port

Two LEDs, LNK/ACT and FDX/COL, convey the status of the port as detailed on the following table

❷ Port Status for the TX port

Three LEDs, LNK/ACT, FDX/COL, and 100, convey the status of the port as detailed on the following table.

Table 2: Port status display LEDs for compact-size, 1 port TX, 1 port FX (part# LB9002A-ST/SC-R2)

LED	State	Indication
LNK/ACT (link/activity)	Steady	The port has established a valid network connection
	Flashing	The port is receiving or transmitting data
100	Steady	The port has established a valid 100 Mbps connection
	Off	The port has established a valid 10 Mbps network connection

FDX/COL (full-duplex/collision)	Steady	The connection is in full-duplex mode
	Flashing	Collision occurred in the 10/100 domain
	Off	The connection is in half-duplex mode

*Collision will only occur on the half-duplex mode of transmission between two devices.

③ Power

This LED illuminates when the switch is connected to a power supply and turned on.

④ MDI Button

Also referred to as the uplink button.

LB9108A

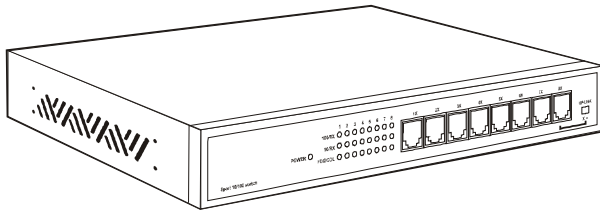

Figure 6: Compact-size, eight-port LB9108A

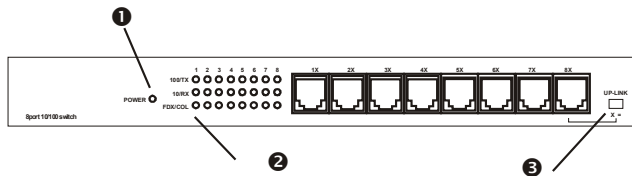

Figure 7: LED and function features of the LB9108A

① Power

This LED illuminates when the switch is connected to a power supply and turned on.

② Port Status

A set of three LEDs conveys the status of each port, as detailed on the following chart.

Table 3: Port status display LEDs for compact-size, 8-port LB9108A

LED	State	Indication
100/TX (100 Mbps/transmit)	Steady	The port has established a valid 100 Mbps network connection
	Flashing	The port is transmitting data
10/RX (10 Mbps/receive)	Steady	The port has established a valid 10 Mbps connection
	Flashing	The port is receiving data
FDX/COL (full-duplex/collision)	Steady	The connection is in full-duplex mode
	Flashing	Collision occurred in the 10/100 domain*
	Off	The connection is in half-duplex mode

*Collision will only occur on the half-duplex mode of transmission between two devices.

🔘 Uplink Switch

Use the uplink port with the uplink switch slid to the right for connecting to a regular port of a hub or another switch.

Illustrated Rackmount-Size Switches

This section covers the rackmount-size, 8-port, 16-port, or 24-port switches

LB9007A-ST-R2/LB9007A-SC-R2

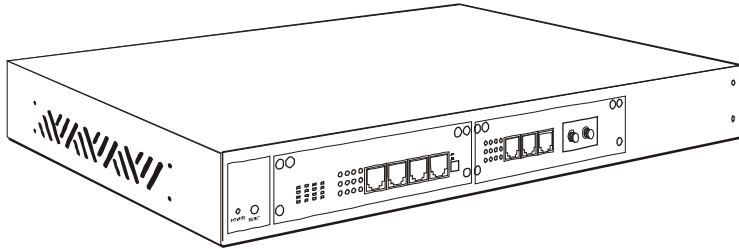

Figure 8: Rackmount-size, 8-port switch with one port of fiber, shown in ST; LB9007A-ST-R2 or LB9007A-SC-R2

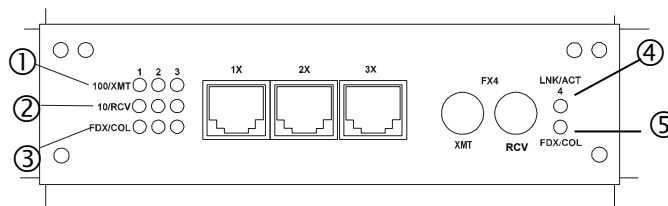

Figure 9: LED and functions of the Rackmount-size, 7-port switch with one port of fiber, shown in ST; LB9007A-ST-R2 or LB9007A-SC-R2

❶ 100/XMT 100Mbps/Transmit

When light is *steady*: indicates presence of 100Mbps fast Ethernet
 When light is *flashing*: indicates traffic transmission

❷ 10/RCV 10Mbps/Receive

When light is *steady*: indicates presence of 10Mbps Ethernet
 When light is *flashing*: indicates traffic receipt

❸ FDX/COL Full-duplex/Collision

When light is *steady*: indicates presence of full-duplex operation
 When light is *flashing*: indicates a collision on the port

Table 4: FX port status display LEDs for rackmount-size, eight-port switch LB9007A-ST-R2 or LB9007A-SC-R2

LED	State	Indication
LNK/ACT	Steady	The port has established a valid network connection
	Flashing	The port is transmitting data
FDX/COL	Steady	The connection is in full duplex mode
	Flashing	The port is receiving data

4 LNK/ACT Link/Activity

When light is *steady*: indicates a proper link to another working device

When light is *flashing*: indicates activity between ports

5 FDX/COL Full-duplex/Collision

When light is *steady*: indicates presence of full-duplex operation

When light is *flashing*: indicates a collision on the port

Table 5: TX ports status display LEDs for rackmount-size, eight-port switch LB9007A-ST-R2 or LB9007A-SC-R2

LED	State	Indication
100/XMT	Steady	The port has established a valid 100Mbps network connection
	Flashing	The port is transmitting Data
10/RCV	Steady	The port has established a valid 10Mbps network connection
	Flashing	The port is receiving Data
FDX/COL	Steady	The connection is in full duplex mode
	Flashing	Collision occurred in the 10/100 domain.
	Off	The connection is in half duplex mode

LB9021A & LB9022A

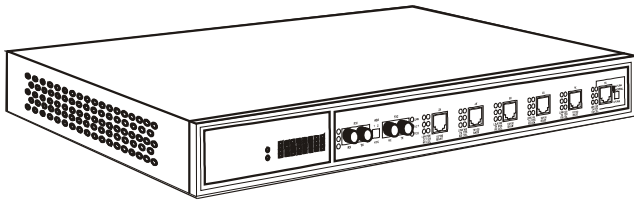

Figure 10 Rackmount-size, 6-port switch with 2-port of fiber, shown in ST; LB9021A-or LB9022A

LB9006A-ST or LB9006A-SC

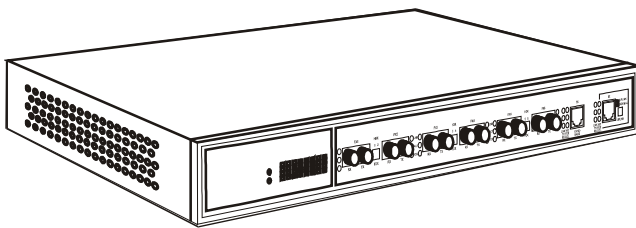

Figure 11: Rackmount-size, 6 ports fiber, 2 ports TX, shown in ST; LB9006A-ST or LB9006A-SC

LB9008A-FO

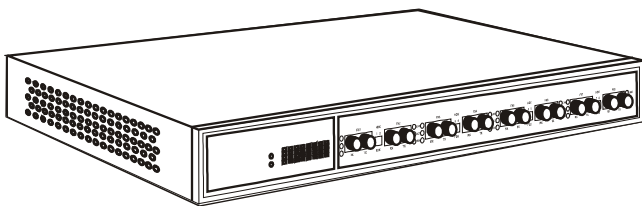

Figure 12: Rackmount-size, 8 ports of fiber LB9008A-FO

The following figures illustrate the LED and functions of LB9021A, LB9022A, LB9006A-ST, LB9006A-SC, LB9008A-FO.

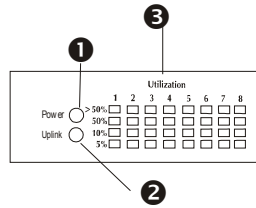

Figure 13: Left front panel of LB9021A, LB9022A, LB9006A-ST, LB9006A-SC, LB9008A-FO.

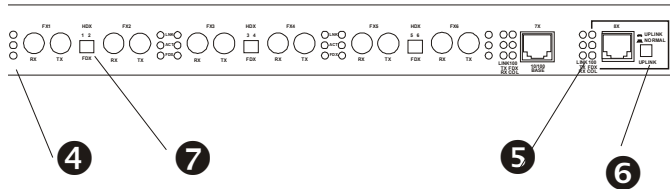

Figure 14: Port status display LEDs of LB9021A, LB9022A, LB9006A-ST, LB9006A-SC, LB9008A-FO.

❶ Power

This LED illuminates when the switch is connected to a power supply and turned on.

❷ Uplink Status

This LED illuminates when the uplink button is pressed down. There is no need for uplink function on 8-port fiber switch.

❸ Port Utilization

The Port Utilization LEDs indicates how much traffic each port is handling, measured as a percentage of the port's bandwidth. Column 1 corresponds to Port 1, Column 2 to Port 2, Column 3 to Port 3, etc. As traffic on a port increases, the LEDs for its column will light progressively from bottom to top.

❹ Fiber Port Status

Three LEDs convey the status of each fiber port as detailed on the following chart.

Table 6: FX port status display LEDs of LB9021A, LB9022A, LB9006A-ST, LB9006A-SC, LB9008A-FO.

LED	State	Indication
LNK (link)	Steady	The port has established a valid network connection
ACT (activity)	Flashing	The port is transmitting or receiving data
FDX (full-duplex)	Steady	The connection is in full-duplex mode
	Off	The connection is in half-duplex mode

⑤ TX Port Status

An array of six LEDs conveys the status of each TX port as detailed on the following chart.

Table 7: TX port status display LEDs for of LB9021A, LB9022A, LB9006A-ST, LB9006A-SC, LB9008A-FO.

LED	State	Indication
LNK (link)	Steady	The port has established a valid network connection
100	Steady	The port has established a valid 100 Mbps connection
TX (transmit)	Flashing	The port is transmitting data
FDX (full-duplex)	Steady	The port is operating in full-duplex mode
	Off	The port is operating in half-duplex mode
RX (receive)	Flashing	The port is receiving data
COL (collision)	Flashing	Collision occurred in the 10/100 domain*

*Collision will only occur on the half duplex mode of transmission between two devices.

⑥ Uplink Button

There is no need for an uplink button on the switch with 8 ports of fiber.

⑦ DIP Switch

DIP switches between every two sets of fiber ports allow a choice between full-duplex or half-duplex transmission. Moving the DIP switch up allows half-duplex transmission. When in the down position, the unit operates in full-duplex transmission.

LB9012A-R2

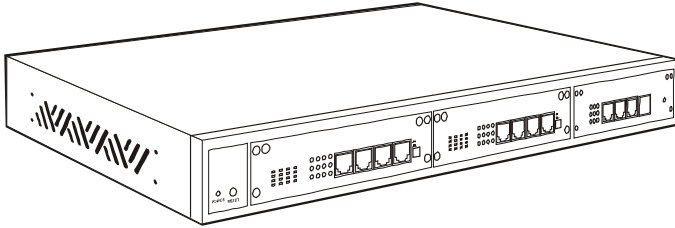

Figure 15: Rackmount size, 12 ports LB9012A-R2

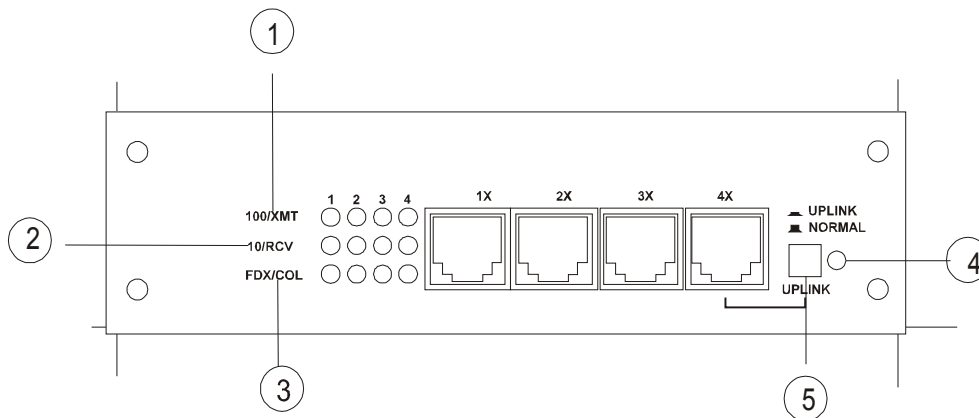
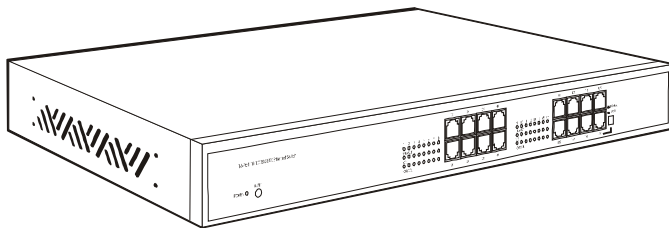
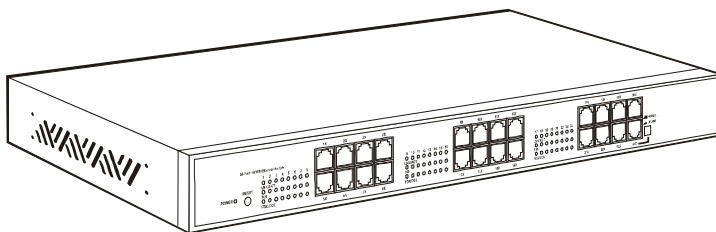

Figure 16: Front panel for 12 ports LB9012A-R2

- ❶ 100/XMT** 100Mbps/Transmit
 When light is *steady*: indicates presence of 100Mbps fast Ethernet
 When light is *flashing*: indicates traffic transmission
- ❷ 10/RCV** 10Mbps/Receive
 When light is *steady*: indicates presence of 10Mbps Ethernet
 When light is *flashing*: indicates traffic receipt
- ❸ FDX/COL** Full-duplex/Collision
 When light is *steady*: indicates presence of full-duplex operation
 When light is *flashing*: indicates a collision on the port

Table 8: TX ports status display LEDs for rackmount-size, twelve-port switch LB90012A-R2

LED	State	Indication
100/XMT	Steady	The port has established a valid 100Mbps network connection
	Flashing	The port is transmitting Data
10/RCV	Steady	The port has established a valid 10Mbps network connection
	Flashing	The port is receiving Data
FDX/COL	Steady	The connection is in full duplex mode
	Flashing	Collision occurred in the 10/100 domain.
	Off	The connection is in half duplex mode

LB9019A**Figure 17: Rackmount size, 16 ports LB9019A****LB9020A****Figure 18: Rackmount size, 24 ports LB9020A****LB9017A-R2**

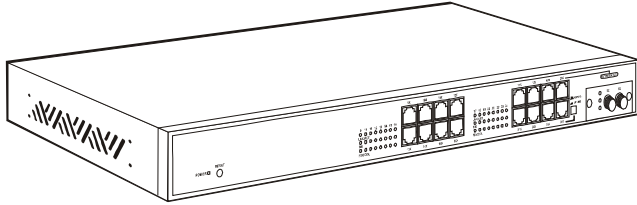

Figure 19: Rackmount size, 16 ports with optional fiber module and special features (see the following special features section) LB9017A-R2

LB9024A

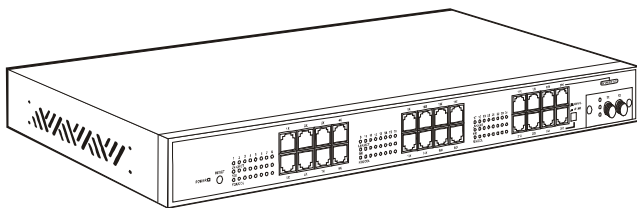

Figure 20: Rackmount size, 24 ports with optional fiber module and special features (see the following special features section) LB9024A

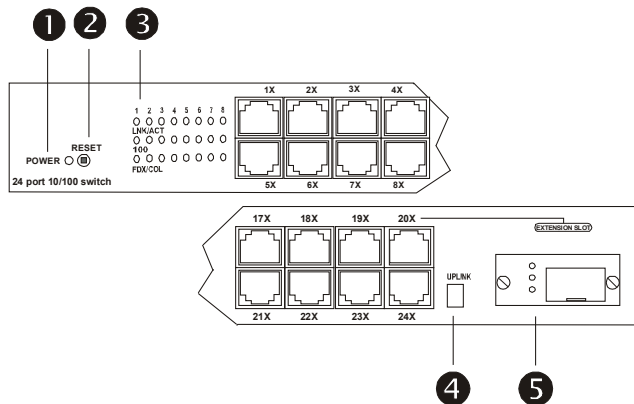

Figure 21: Front panel for 16 or 24 ports LB9019A, LB9020A, LB9017A-R2, LB9024A

- ❶ Power indicator
- ❷ Reset button
- ❸ LED port status display

The following chart details the LED status displays.

Table 9: Port Status Display

LED	State	Indication
LNK (link)	Steady	The port has established a valid network connection
ACT (activity)	Flashing	The port is transmitting or receiving data
FDX (full-duplex)	Steady	The connection is in full-duplex mode
	Off	The connection is in half-duplex mode

④ Uplink button

⑤ **Optional fiber module for LB9017A-R2 & LB9024A**

Refer to the following Special Features section for installation instructions.

Special features for LB9007A-ST-R2, LB9007A-SC-R2, LB9012A-R2, LB9017A & LB9024A

LB9007A-ST-R2, LB9007A-SC-R2, LB9012A-R2, LB9017A & LB9024A house a console port that enables connection to establish a VLAN (virtual local area network), port aggregation, the setting of half or full-duplex transmission, and the setting of 10Mbps or 100Mbps for TX transmission.

For these features to operate through the console port, it is necessary to first configure in DOS or a terminal emulation program such as HyperTerminal.

Setting up Console Port Connection

To configure these features through the console port, it is necessary to first configure a terminal emulation program in DOS or in Windows such as HyperTerminal.

- Check the switch, cables, and computers for proper installation before configuration.
- Attach a PC or any VT100 compatible terminal to the console port on the back of the switch (see figure 6) using the following settings:

Terminal type	VT100
Port type	(COM 1~4)
Communication Mode	8 data bits, 1 stop bit, no parity and 9600bps (for initial configuration)
Flow Control	None
Hardware Compression	NA

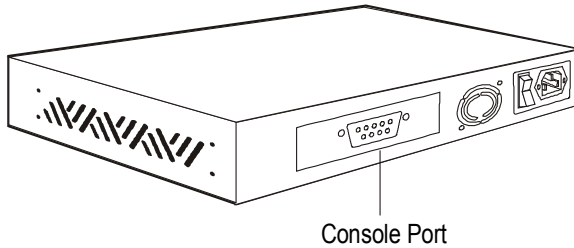

Figure 22: Console Port

VLAN and Speed/Duplex port setting for LB9007A-ST-R2, LB9007A-SC-R2 & LB9012A-R2

- Turn on the switch and press any key to view the main menu shown below:

SLOT	VLAN	Port List
A. 4TX	V1	A1,A2,A3,B1, B2, B3, B4,
B. 3TX1FX	V2	<empty>
C. Empty	V3	<empty>
	V4	<empty>

Port	Type	Speed/Duplex Mode	Flow Control	VLAN List
A1	TX	Auto->100TX,Full	On	V1
A2	TX	Auto->100TX,Full	On	V1
A3	TX	Auto->100TX,Full	On	V1
A4	TX	Auto->100TX,Full	On	V1
B1	TX	Auto->100TX,Full	On	V1
B2	TX	Auto->100TX,Full	On	V1
B3	TX	Auto->100TX,Full	On	V1
B4	FX	100FX-Fullduplex	On	V1
C1	N/A			
C2	N/A			
C3	N/A			
C4	N/A			

Please enter the VLAN# or ESC to Abort (V1-V4)->

Figure 23: Console Port Display

Valid commands:

- [V] Configure VLAN groups
- [M] Select 10/100Mbps and half or full-duplex mode
- [T] Performing port aggregation
- [D] Restore the default settings
- [ESC] Abort and return to the menu

Default Settings:

TX ports: assigned to V1, auto-negotiation, and flow control ON.

FX ports: assigned to V1, 100FX full-duplex, and flow control ON.

The console port menu displays the current settings (i.e.: **auto->100TX full**) or, if the port is not connected, displays the message **auto->No Link**.

Establishing a VLAN for LB9007A-ST-R2, LB9007A-SC-R2 & LB9012A

Virtual Local Area Networks (VLANs) enable segmenting of the LAN without regards to physical location. Assign each port to a VLAN group or set of groups according to accessibility needs. Thus, a specific port could be in more than one VLAN group. There are 4 VLAN groups available for models specified here.

The port numbers are designated alpha-numerically. The letters A, B, and C identify three slots from left to right and the ports are numbered 1 through 4. Therefore, the port # is a combination of the slot (A-C) and the position of the port in that section (1-4). LB9012A has 3 slots and LB9007A-SC/ST-R2 have 2 slots A & B only.

Follow these steps to assign port(s) to a VLAN group.

- Enter [V] from the Main Menu
- Select a VLAN group: [V1], [V2], [V3], or [V4]
- Enter the port #.

Note: If entering more than one port to a VLAN group, separate each port # by commas without spaces or dashes. To enter an entire module, enter only the letter (A, B, or C).

Only one VLAN group can be defined at a time. Repeat selecting VLAN groups and assigning ports until all ports are assigned to at least one VLAN group. Though each VLAN grouping does not need to be utilized, each port must be assigned to at least one VLAN group. Hit the [ESC] key when done.

To return to the default settings (in which each port is assigned to V1), enter [D] from the main menu. A prompt appears to verify this action.

VLAN Example:

- Enter [V1] (no [ENTER])

The current V1 is A1,A2,A3,A4,B1,B2,B3,B4,
Please enter the new port list ->

- Key A1,B4,C2

Proceed with the assignment of the remainder of the ports into any VLAN grouping:

- Enter [V2] (no [ENTER])
- Key A1,B1,B2,B3,
- Enter [V3] (no [ENTER])
- Key A2, A3, A4

*Note: Until assigned, the menu displays ****error**** for each unassigned port. While any port is in the ****error**** status, the [ESC] key will not return the screen to the main menu. Assign each port to a VLAN grouping prior to exiting program.*

View the results on the following illustration.

SLOT	VLAN	Port List
A. 4TX	V1	A1,B4,
B. 3TX1FX	V2	A1,A2,B1,B2,B3,
C. Empty	V3	A2,A3,A4
	V4	<empty>

Port	Type	Speed/Duplex Mode	Flow Control	VLAN List
A1	TX	Auto->100TX,Full	On	V1 V2
A2	TX	Auto->100TX,Full	On	V2 V3
A3	TX	Auto->100TX,Full	On	V3
A4	TX	Auto->100TX,Full	On	V3
B1	TX	100FX-Fullduplex	On	V2
B2	TX	100FX-Fullduplex	On	V2
B3	TX	100FX-Fullduplex	On	V2
B4	FX	100FX-Fullduplex	On	V1
C1	N/A			
C2	N/A			
C3	N/A			
C4	N/A			

Please enter the VLAN# or ESC to Abort (V1-V4)->

Performing Port Aggregation

The aggregation or trunking of ports enables an aggregate of bandwidth between like switches. Attaching the console port to a PC or any VT100 compatible unit launches a main menu screen displayed by hitting any key. The Escape key quits the program functions. The [T] command displays further parameters that define which ports or number of ports that can be in one trunk, or the number of possible trunks. The VLAN function might become disabled on trunked ports.

Configure Port Settings

The duplex mode and speed can be altered and the flow-control can be turned off to accommodate special needs.

The port numbers are designated alpha-numerically. The letters A, B, and C identify the module slots from left to right and the ports are numbered 1 through 4. Therefore, the port # is a combination of the slot (A-C) and the position of the port in that slot (1-4). On the console port display screen, a description of the number of TX and FX ports (such as 1FX, 4TX) further identifies the module slots.

Follow these steps to change the speed/duplex mode setting or to toggle flow control ON/OFF:

- Enter [M] (no [ENTER])
- Select a port
- Select the media from the list that appears on the screen

Note: Only one port can be changed at a time.

Consult the following charts for a brief description:

Table 5: TX Port Settings

#	Mode	Description
0	Flow Control *	Toggles ON/OFF

1	Auto **	Auto-Negotiation
2	100TX, full-duplex	100Mbps at full-duplex
3	100TX, half-duplex	100Mbps at half-duplex
4	10TX, full-duplex	10Mbps at full-duplex
5	10TX, half-duplex	10Mbps at half-duplex

* Default setting is flow control ON

** Default setting is auto-negotiation

Table 6: FX Port Settings

#	Mode	Description
0	Flow Control *	Toggles ON/OFF
1	100FX, full-duplex **	100Mbps at full-duplex
2	100FX, half-duplex	100Mbps at half-duplex

* Default setting is flow control ON

**Default setting is 100FX, full-duplex

Media Setting Example

- Enter [M] (no [enter])
- Select port A4
- Select mode 5

Hit the [ESC] key when done. To return to the default settings, enter [D]. A prompt appears to verify this command.

View the results on the following illustration.

```

SLOT      VLAN   Port List
-----
A. 4TX    V1    A1,B4,
B. 3TX1FX V2    A1,A2,B1,B2,B3,
C. Empty  V3    A2,A3,A4
          V4    <empty>

Port  Type  Speed/Duplex Mode  Flow Control  VLAN List
-----
A1  TX   Auto->100TX,Full  On   V1  V2
A2  TX   Auto->100TX,Full  On   V2  V3
A3  TX   Auto->100TX,Full  On   V3
A4  TX   10TX, Halfduplex  On   V3
B1  TX   100FX-Fullduplex  On   V2
B2  TX   100FX-Fullduplex  On   V2
B3  TX   100FX-Fullduplex  On   V2
B4  FX   100FX-Fullduplex  On   V1
C1  N/A
C2  N/A
C3  N/A
C4  N/A

VLAN,Mode,Default (V/M/T/D)?

```

VLAN and Speed/Duplex port setting for LB9017A-R2, LB9024A

- * Please see page 23 on setting up console port.
- After setting up the console port, turn on the switch and press any key to view the main menu shown below:

VLAN		Port List	
V1	1,2,3,4,5,6,7,8,9,10,11,12		
V2	<empty>		
V3	<empty>		
V4	<empty>		

Port	Mode	Flw	VLAN List	Port	Mode	Flw	VLAN List
1	Auto	On	V1	7	Auto	On	V1
2	Auto	On	V1	8	Auto	On	V1
3	Auto	On	V1	9	Auto	On	V1
4	Auto	On	V1	10	Auto	On	V1
5	Auto	On	V1	11	Auto	On	V1
6	Auto	On	V1	12	Auto	On	V1

Figure 24: Console port displaying default settings

Default Settings:

All ports reside in the V1 group using auto-negotiation and flow control in the default mode.

Valid Commands:

- [V] Configure VLAN groups
- [M] Select 10/100Mbps and half or full-duplex mode
- [D] Restore the default settings
- [ESC] Abort and return to the menu

Establishing a VLAN

Virtual Local Networks (VLANs) enable segmentation of the LAN without regards to physical location. Configure the ports to reside in up to four VLANs (virtual local area networks). Attaching the console port to a PC or any VT100 compatible unit launches a main menu screen displayed by hitting any key. The Escape key quits the program functions. The [V] command produces a prompt to enter the VLAN number followed by the corresponding

port(s). Use commas (,) or dashes (-) to list multiple ports, but limit the amount of characters on the command line to 35. Follow these steps to assign ports to a VLAN group.

- Enter **[V]** from the Main Menu
- Select a VLAN group:
- **[V1]**, **[V2]**, **[V3]**, or **[V4]**
- Enter the port #.

To return to the default settings, enter **[D]** from the main menu. A prompt appears to verify this action since all functions are reset to default, not just the VLAN function.

Assign each VLAN group individually and continue assigning ports until all of the ports are assigned to at least one VLAN group. Hit the **[ESC]** key when done. The **[ESC]** key will not return the screen to the main menu until each port is assigned.

VLAN Example:

- Key **[V1]** (NO **[ENTER]**)
- Key 1,2,3,4,5,6,7,8,9
- or 1-9
- **[ENTER]**
- Key **[V2]** (NO **[ENTER]**)
- Key 10,11,12
- or 10-12
- **[ENTER]**
- Key **[V3]** (NO **[ENTER]**)
- Key 1,9,10,11
- or 1,9-11
- **[ENTER]**

The following is the screen display of the above example.

Port	Mode	Flw	VLANList	Port	Mode	Flw	VLANList
1	Auto	On	V1,V3	7	Auto	On	V1
2	Auto	On	V1	8	Auto	On	V1
3	Auto	On	V1	9	Auto	On	V1,V3
4	Auto	On	V1	10	Auto	On	V2,V3
5	Auto	On	V1	11	Auto	On	V2,V3
6	Auto	On	V1	12	Auto	On	V2

Figure 25: Console port displaying revised VLAN assignments according to above example.

Performing Port Aggregation

The aggregation or trunking of ports enables an aggregate of bandwidth between like switches. Attaching the console port to a PC or any VT100 compatible unit launches a main menu screen displayed by hitting any key. The Escape key quits the program functions. The **[T]** command displays further parameters that define which ports or

number of ports that can be in one trunk, or the number of possible trunks. The VLAN function might become disabled on trunked ports.

Configuring Ports

The same menu allows configuration of individual ports to turn off the auto-negotiation, flow-control, or full-duplex transmission features. Attaching the console port to a PC or any VT100 compatible unit launches a main menu screen that is displayed by hitting any key. The Escape key quits the program functions. The **[M]** command displays the options for each port configuration. To change the mode, enter the port number, and then the number representing a selection from the options list displayed on the screen. The list differs between the TX and FX ports. Follow these steps to change the speed/duplex mode setting or to toggle flow control ON/OFF:

- Key **[M]** (NO **[ENTER]**)
- Select a port
- **[ENTER]**
- Select the media from the list that appears on the screen
- Continue with any further ports

The following table is an example of options:

Table 10: TX Port Settings

#	Communication Media	Description
0	Flow Control	Toggles ON/OFF
1	Auto	Auto-Negotiation
2	100 FL	100Mbps at full-duplex
3	100 HF	100Mbps at half-duplex
4	10 FL	10Mbps at full-duplex
5	10 HF	10Mbps at half-duplex

Media Setting Example:

- Key **[M]** (NO **[ENTER]**)
- Select port 10
- Select mode 5

Hit the **[ESC]** key when done. To return to the default settings, enter **[D]**. A prompt appears to verify this command since all options will revert to default mode, not just the media settings. The following is the screen display of the above example.

```

VLAN Port List
-----
V1 1,2,3,4,5,6,7,8,9,10,11,12,13,14,15,16,17,18,19,20,21,22,23,24
V2 <empty>
V3 <empty>
V4 <empty>
Port Mode Flw VLAN List Port Mode Flw VLAN List
1 Auto On V1 7 Auto On V1
2 Auto On V1 8 Auto On V1
3 Auto On V1 9 Auto On V1
4 Auto On V1 10 10HF On V1
5 Auto On V1 11 Auto On V1
6 Auto On V1 12 Auto On V1

```

Figure 26: Console port displaying mode change

Fiber Module Installation

- Turn off the power. The module is not hot-swappable.
- Remove the cover plate, retaining screws and plate for later replacement
- Slide in the module, following the guides
- Snap in the module to attain a firm connection

Product Specifications

All Black Box Express Ethernet Switches auto-negotiate 10/100 Mbps, use store-and-forward and non-blocking architectures and use back pressure for half-duplex and IEEE 802.3x compliant flow-control for full-duplex. The Express Ethernet Switches support substantial MAC entries with address filtering and relearning capabilities.

ETHERNET STANDARDS

IEEE 802.3 10BASE-T; IEEE 802.3u 100BASE-TX/FX

CABLE

10BASE-T: 2-pair UTP Cat. 3, 4, or 5;

100BASE-TX: 2-pair UTP Cat. 5;

100BASE-FX: 62.5/125 multi-mode fiber-optic cable

SWITCHING METHOD

Store-and-Forward

FORWARDING RATE

14,800 pps for 10 Mbps;

148,800 pps for 100 Mbps

TEMPERATURE

Operating: 32 to 104°F (0 to 40°C)

Storage: -13 to +158°F (-25 to +70°C)

HUMIDITY

10 to 90% non-condensing

EMISSION COMPLIANCE AND SAFETY STANDARDS

FCC part 15 Class B, CE Mark, VCCI, cUL

Table 8: Specifications per model

Model	Dimension "W x "D x "H	Weight	Output	Pwr
LB9002A-SC/ST	10 x 5.3 x 1.4 25.4 x 13.5 x 3.6 cm	2.1 lb. 0.9 kg	100-250VAC 47-63 Hz	7W
LB8405A	5.2 x 4.5 x 0.9. 13.2 x 11.4 x 2.3 cm	0.9 lb. 0.4 kg	100-120VAC 50-60 Hz	7.2W max.
LB8408A	5.2 x 4.5 x 0.9 13.2 x 11.4 x 2.3 cm	0.9 lb. 0.4 kg	100-120VAC 50-60 Hz	7.2W max.
LB9108A	10 x 5.3 x 1.4 25.4 x 13.5 x 3.6 cm	3.5 lb. 1.6 kg	100-250VAC 47-63 Hz	11W max.
LB9007A-SC/ST-R2	17.3 x 8.0 x 1.8 43.9 x 20.3 x 4.6 cm	5.5 lb. 2.5 kg	100-250VAC 47-63 Hz	13W
LB9006A-SC/ST	17.3 x 8.0 x 1.8 43.9 x 20.3 x 4.6 cm	5.5 lb. 2.5 kg	100-250VAC 47-63 Hz	20W
LB9021A	17.3 x 8.0 x 1.8 43.9 x 20.3 x 4.6 cm	5.5 lb. 2.5 kg	100-240VAC 50-60 Hz	35W max
LB9022A	17.3 x 8.0 x 1.8 43.9 x 20.3 x 4.6 cm	5.5 lb. 2.5 kg	100-240VAC 50-60 Hz	35W max
LB9008A-FO	17.3 x 8.0 x 1.8 43.9 x 20.3 x 4.6 cm	5.5 lb. 2.5 kg	100-250VAC 47-63 Hz	22W
LB9012A-R2	17.3 x 8.0 x 1.8 43.9 x 20.3 x 4.6 cm	5.5 lb. 2.5 kg	100-240VAC 50-60 Hz	35W max
LB9019A	17.3 x 8.0 x 1.8 43.9 x 20.3 x 4.6 cm	5.5 lb. 2.5 kg	100-260VAC 47-63 Hz	30W max
LB9020A	17.3 x 8.0 x 1.8 43.9 x 20.3 x 4.6 cm	5.5 lb. 2.5 kg	100-260VAC 47-63 Hz	30W max
LB9017A-R2	17.3 x 8.0 x 1.8 43.9 x 20.3 x 4.6 cm	5.7 lb. 2.6 kg	100-250VAC 47-63 Hz	24W
LB9024A	17.3 x 8.0 x 1.8 43.9 x 20.3 x 4.6 cm	6.4 lb. 2.9 kg	100-250 VAC 47-63 Hz	30W

Installation

Quick Tip

Install a Black Box Express Ethernet Switch as a plug-and-play device. No special configuration is required. Details below are consistent with the installation of any electronic device

Place the Black Box Express Ethernet Switch where it will not be subjected to extreme temperatures, humidity, or electromagnetic interference. Specifically, the site you select should meet the following requirements:

- The room temperature should be between 32 and 104 degrees Fahrenheit (0 to 40 degrees Celsius).
- The relative humidity should be less than 90 percent, non-condensing.
- Surrounding electrical devices should not exceed the electromagnetic field (RFC) standards for IEC 801-3, Level 2 (3V/M) field strength.
- Make sure that the switch receives adequate ventilation. Do not block the ventilation holes on the side of the switch or the fan exhaust port on the rear of the switch.
- The power outlet should be within 1.8 meters of the switch.

Connecting to Power

Connect the supplied AC power cord to the receptacle on the back of the switch, and then plug the cord into a standard AC outlet with a voltage range from 100 to 120 VAC. For external power supply units, plug the jack into the DC receptacle on the front of the unit, and plug the power supply unit into a 110 AC outlet. Turn the switch on by flipping the ON/OFF switch on the rear of the unit to the I (ON) position. The O position is OFF.

Connecting to Your Network

If you are making a connection to a server or workstation, be sure that it has a properly installed 100BASE-TX (or 100BASE-FX if the switch does not contain 100BASE-TX ports) network interface card. Connect the RX/TX jacks on the target device to the TX/RX jacks on the switch and the RJ-45 jacks on the target device to the RJ-45 jacks on the switch.

Use the uplink port for connecting to a regular (i.e. non-uplink) port of a hub or another switch. If connecting to an uplink port of a hub or another switch, use any port. There is no uplink issue with fiber ports.

Copper-based cabling

Connect cables to computers or network segments into the RJ-45 ports on the front of the switch.

The cable must be a Category 5 shielded twisted-pair or unshielded twisted-pair (STP/UTP) cable for 100BASE-TX, or Category 3, 4, or 5 STP/UTP cable for 10BASE-T. Consult Table 9 for further details.

Fiber-optic cabling

Prepare a pair of fiber optic cables with SC or ST type connectors at both ends. The cable for fiber ports must be a 62.5/125 micron fiber-optic cable for 100BASE-FX. Consult Table 9 for further details.

Table 9: Cable Specifications

Speed	Connector	Port Speed Half/Full Duplex	Cable	Range
100BASE-TX	RJ-45	100/200 Mbps	Category 5 UTP	100 meters

10BASE-T	RJ-45	10/20 Mbps	Category 3, 4, or 5 UTP	100 meters
100BASE-FX	ST or SC	200 Mbps	62.5/125 micron fiber-optic cable	2 kilo-meters

Uplink or MDI Function

A network of switches connected (or cascaded) together via uplink ports is termed a “collapsed backbone.” The uplink function transforms the adjacent or indicated port into an uplink port with a push of the button or by sliding the switch. This allows connection to another switch or hub without preparing crossover cable. However, this is unnecessary when either connecting directly to the uplink port of another switch or hub or when connecting fiber ports between switches or hubs.

Trouble-shooting Guide

This trouble-shooting guide describes problems that could occur with the Express Ethernet Switch. The guide states possible reasons for the problems, and possible steps to take to solve the problems.

No Power to the Switch.

Symptom: Power cord is connected to the switch, but all LEDs, including the Power LED, are off.

Possible Problem	Solution
Loose power connection or faulty power supply	<ol style="list-style-type: none"> 1. Check both ends of the power cord to make certain that they are securely connected to the power receptacle on the switch and to the power outlet. 2. Verify that the power outlet has power.

No Connectivity to the Data Terminal Equipment.

Symptom: An Ethernet switch cannot communicate to the directly connected computers or network segments.

Possible Problem	Solution
Incorrect or faulty cabling	<ol style="list-style-type: none"> 1. Check cables for a secure connection. 2. Verify that the correct type of cable is in use. <ul style="list-style-type: none"> • For connection to a PC or a network interface card (NIC), use a straight-through cable. • For uplink to another switch or hub, use a cross-wire cable, or use a regular straight-through cable connected to the uplink port with the uplink button activated. • Refer to Table 9 for cable specifications. 1. Verify proper cable preparation. 2. Use a time domain reflectometer (TDR) or other cable-checking device to verify that the cable has no opens, shorts, or other problems. 3. Swap the cable with another of the same kind to see if the cable is bad. <ul style="list-style-type: none"> • Replace or fix the faulty cable as necessary.
Dysfunctional NIC on a PC or workstation	Run the diagnostic supplied by the vendor on the NIC to determine if it is functioning properly. If it is not, replace it.
Packet Overflow or Hardware problem	Reset the switch by pressing the reset button or turn the switch off, then on again.

No Connectivity to Certain Nodes on the Network

Symptom: Data terminal equipment (DTE) connected to the switch can not send or receive information from certain segments on the same network or across to another LAN or WAN.

Possible Problem	Solution
Hardware problem	Check for a damaged RJ-45 jack, or fiber SC or ST type connector.

Transmission Problems**Symptom:** Connections across a LAN switch are slow or unreliable.

Possible Problem	Solution
Incorrect full- or half-duplex settings	<p>Express Ethernet Switches are all equipped with auto-negotiation to communicate with other DTEs on the network for the best available performance.</p> <ol style="list-style-type: none"> 1. Verify if the connected NIC is equipped with auto-negotiation (this is not the same as auto-sensing). 2. Change the DIP switch setting if available.
Exceeded cabling distance or misused cable	<ol style="list-style-type: none"> 1. Ensure that the proper cable is in use and that the recommended distance is not exceeded. For information, refer to Table 9. 2. Check the cable distance using a cable tester or TDR. Verify that the cable lengths attached to the switch meet Ethernet/IEEE 802.3 specifications. 3. If the distance is out of specification, reduce the length of the cable or add a repeater, ensuring no more than four repeaters are attached.
Bad adapter in attached device	Check the switch port statistics. If excessive errors are found, run the adapter card diagnostic utility to determine the problem.

Trademarks

Any trademarks are acknowledged to be the property of the trademark owners.

Glossary

10BASE-T	Networking standard for twisted-pair cabling capable of carrying data at 10 Mbps.
100BASE-TX	Networking standard for two pairs of high-quality twisted-pair wires carrying data at 100 Mbps.
100BASE-FX	Networking standard for fiber-optic cabling capable of carrying data at 100 Mbps.
auto-negotiation	Two-part process by which a network device automatically senses the speed and duplex capability of another device.
Category 5	Networking standard certifying that a copper wire cable can carry data at up to 100 Mbps.
collision	Concurrent Ethernet transmissions from two or more devices on the same segment.
Ethernet	Networking standard for transmitting data at 10 Mbps.
Fast Ethernet	Networking standard for transmitting data at 100 Mbps.
fiber-optic cable	Cable made of thin glass threads that carry data in the form of light pulses.
full-duplex	A communications technique that allows bi-directional, simultaneous transmission between two devices on a single segment.
half-duplex	A communications technique in which one device on a segment transmits while the other receives, then the process is reversed.
IEEE 802	Set of Institute of Electrical and Electronic Engineers standards for defining methods of access and control on LANs.
LAN	Local area network. A network where computers are connected in close proximity, such as in the same building or office park. A system of LANs connected at a distance is called a wide-area network (WAN).
MAC address	Media access control address. A hardware address that uniquely identifies each node of a network.
Mbps	Millions of bits per second.
segment	Section of a network bounded by bridges, routers, hubs, or switches. Dividing an Ethernet into multiple segments is a common way to increase bandwidth on a LAN.
store-and-forward	Switching feature where the port receives the entire incoming frame and stores it in the buffers while checking for runts and error frames before forwarding it to the destination port.
switch	Device that filters and forwards packets between LAN segments.
UTP	Unshielded twisted pair; cabling with wires that are twisted around each other. The individual wires are not insulated.
wire speed	The ability to handle the fastest rate of traffic that a generator can deliver without dropping packets. On a 100 Mbps connection, wire-speed traffic is 148,809 packets per second using 64-byte frames or 8,127 packets per second using 1,518-byte frames.