

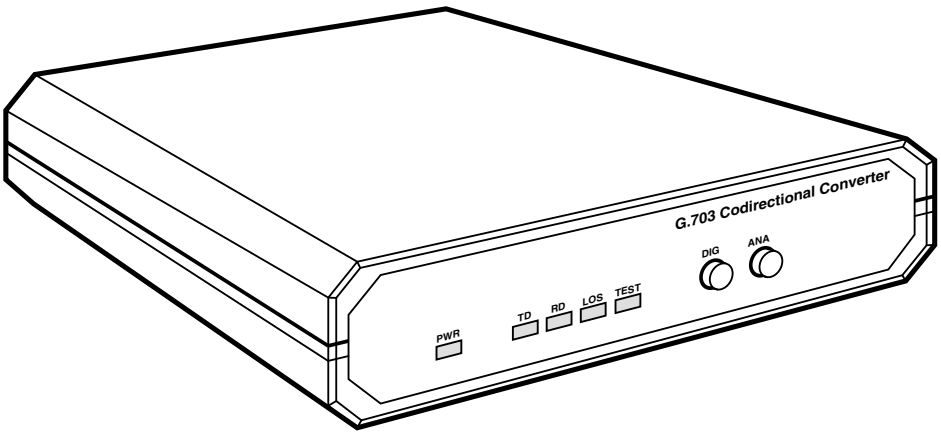

G.703 Codirectional Converter



**CUSTOMER
SUPPORT
INFORMATION**

Order toll-free in the U.S.: Call **877-877-BBOX** (outside U.S. call **724-746-5500**)
FREE technical support 24 hours a day, 7 days a week: Call **724-746-5500** or fax **724-746-0746**
Mailing address: **Black Box Corporation**, 1000 Park Drive, Lawrence, PA 15055-1018
Web site: www.blackbox.com • E-mail: info@blackbox.com

**FEDERAL COMMUNICATIONS COMMISSION
AND
INDUSTRY CANADA
RADIO FREQUENCY INTERFERENCE STATEMENTS**

This equipment generates, uses, and can radiate radio-frequency energy, and if not installed and used properly, that is, in strict accordance with the manufacturer's instructions, may cause interference to radio communication. It has been tested and found to comply with the limits for a Class A computing device in accordance with the specifications in Subpart B of Part 15 of FCC rules, which are designed to provide reasonable protection against such interference when the equipment is operated in a commercial environment. Operation of this equipment in a residential area is likely to cause interference, in which case the user at his own expense will be required to take whatever measures may be necessary to correct the interference.

Changes or modifications not expressly approved by the party responsible for compliance could void the user's authority to operate the equipment.

This digital apparatus does not exceed the Class A limits for radio noise emission from digital apparatus set out in the Radio Interference Regulation of Industry Canada.

Le présent appareil numérique n'émet pas de bruits radioélectriques dépassant les limites applicables aux appareils numériques de la classe A prescrites dans le Règlement sur le brouillage radioélectrique publié par Industrie Canada.

**NORMAS OFICIALES MEXICANAS (NOM)
ELECTRICAL SAFETY STATEMENT****INSTRUCCIONES DE SEGURIDAD**

1. Todas las instrucciones de seguridad y operación deberán ser leídas antes de que el aparato eléctrico sea operado.
2. Las instrucciones de seguridad y operación deberán ser guardadas para referencia futura.
3. Todas las advertencias en el aparato eléctrico y en sus instrucciones de operación deben ser respetadas.
4. Todas las instrucciones de operación y uso deben ser seguidas.
5. El aparato eléctrico no deberá ser usado cerca del agua—por ejemplo, cerca de la tina de baño, lavabo, sótano mojado o cerca de una alberca, etc..
6. El aparato eléctrico debe ser usado únicamente con carritos o pedestales que sean recomendados por el fabricante.
7. El aparato eléctrico debe ser montado a la pared o al techo sólo como sea recomendado por el fabricante.
8. Servicio—El usuario no debe intentar dar servicio al equipo eléctrico más allá a lo descrito en las instrucciones de operación. Todo otro servicio deberá ser referido a personal de servicio calificado.
9. El aparato eléctrico debe ser situado de tal manera que su posición no interfiera su uso. La colocación del aparato eléctrico sobre una cama, sofá, alfombra o superficie similar puede bloquea la ventilación, no se debe colocar en libreros o gabinetes que impidan el flujo de aire por los orificios de ventilación.
10. El equipo eléctrico deber ser situado fuera del alcance de fuentes de calor como radiadores, registros de calor, estufas u otros aparatos (incluyendo amplificadores) que producen calor.
11. El aparato eléctrico deberá ser conectado a una fuente de poder sólo del tipo descrito en el instructivo de operación, o como se indique en el aparato.

12. Precaución debe ser tomada de tal manera que la tierra física y la polarización del equipo no sea eliminada.
13. Los cables de la fuente de poder deben ser guiados de tal manera que no sean pisados ni pellizcados por objetos colocados sobre o contra ellos, poniendo particular atención a los contactos y receptáculos donde salen del aparato.
14. El equipo eléctrico debe ser limpiado únicamente de acuerdo a las recomendaciones del fabricante.
15. En caso de existir, una antena externa deberá ser localizada lejos de las líneas de energía.
16. El cable de corriente deberá ser desconectado del cuando el equipo no sea usado por un largo periodo de tiempo.
17. Cuidado debe ser tomado de tal manera que objetos líquidos no sean derramados sobre la cubierta u orificios de ventilación.
18. Servicio por personal calificado deberá ser provisto cuando:
 - A: El cable de poder o el contacto ha sido dañado; u
 - B: Objetos han caído o líquido ha sido derramado dentro del aparato; o
 - C: El aparato ha sido expuesto a la lluvia; o
 - D: El aparato parece no operar normalmente o muestra un cambio en su desempeño; o
 - E: El aparato ha sido tirado o su cubierta ha sido dañada.

G.703 CODIRECTIONAL CONVERTER

TRADEMARKS USED IN THIS MANUAL

Any trademarks mentioned in this manual are acknowledged to be the property of the trademark owners.

Contents

Chapter	Page
1. Specifications	6
2. Introduction	8
2.1 Functional Description	8
2.2 Timing Theory	9
2.2.1 CCITT G.703 Signalling	9
2.2.2 G.703 Codirectional Timing.....	10
2.2.3 Tail-End Clocking	14
2.2.4 G.703 Codirectional Rules.....	14
2.3 Rate-Conversion Rules	16
2.4 Physical Description	16
3. Installation	17
3.1 Unpacking	17
3.2 Site Requirements.....	17
3.3 Setting Jumpers.....	17
3.3.1 Overview.....	17
3.3.2 The Jumper-Setting Procedure	20
3.4 Installation in 19-Inch Racks	20
3.4.1 Overview	20
3.4.2 Installing a Single Unit in a 19-Inch Rack	21
3.4.3 Installing Two Units in a 19-Inch Rack.....	22
3.5 Connecting Power and Data Cables	24
3.5.1 Power Connection.....	25
3.5.2 G.703 LINE Connection	25
3.5.3 DTE Connection	25
3.5.4 Async Secondary-Channel Connection.....	26
4. Operation.....	27
4.1 Front-Panel Controls and LEDs	27
4.2 Operating Instructions	29
4.2.1 Turn-On Procedure	29
4.2.2 Activating Loops.....	29
4.2.3 Turn-Off Procedure	29
4.3 Diagnostic Loops.....	29
Appendix: Pinouts	31

1. Specifications

G.703 INTERFACE:

Type —	Codirectional 64-kbps
Line —	4-wire, 19- to 26-gauge
Range —	Up to 800 meters (½ mile) over 24-gauge wire
Impedance —	120 ohms nominal
Balance —	Better than 45 dB (up to 256 kHz) Better than 35 dB (up to 384 kHz)
Return Loss —	Better than 20 dB (up to 128 kHz) Better than 14 dB (up to 384 kHz)
“Pulse” Amplitude —	1.0 V nominal
“Zero” Amplitude —	0 V ± 0.1 V max
Clock Frequency —	64 kHz
Frequency Tracking —	± 500 ppm
Connector —	5-screw terminal block
Jitter Performance —	To G.823 requirements

DATA-COMMUNICATIONS INTERFACE:

Type —	CCITT V.35; CCITT X.21/V.11; CCITT V.36/V11 (EIA RS-449/RS-422); EIA RS-530
Data Rate —	64, 56, or 48 kbps, user-selectable
Spare Bandwidth —	(at 56 or 48 kbps) “1’s” density bit stuffing as per CCITT V.110; additional synchronous channel at 1200 bps; transfer of RTS to DCD control signal, end-to-end
Connector —	DB25 female

DATA-COMMUNICATIONS CONTROL SIGNALS:

- Electrical** — CCITT V.28 (unbalanced, as per V.35)
- Functional** — *DCD, 64 kbps:* ON when Rx pair contains required violations, OFF when the Rx pair does not contain required violations;
DCD, 48 or 56 kbps: When the Rx pair contains the required violations, the DCD signal reflects the state of the remote RTS; DCD is always OFF when no violations are detected;
CTS output: ON after RTS ON, with delay; OFF when RTS OFF, or during Loss of Signal condition;
DSR output: ON (+V) when power is available
- Clock Source** — From G.703 Receive pair (LBT), from DCE (EXT), or from internal source (INT), user-selectable
- Data Polarity** — Normal (MARK = "0") or inverted (MARK = "1"), user-selectable

OTHER PHYSICAL SPECIFICATIONS:

- Indicators** — (5) Front-mounted LEDs: Power (PWR), Receive Data (RD), Transmit Data (TD), Loss of Signal (LOS), and Test (TEST)
- Temperature** — 32 to 122°F (0 to 50°C)
- Humidity** — Up to 95% non-condensing
- MTBF** — 110,000 hours
- Power** — Directly from outlet:
Voltage: 115 VAC (IC713A) or 230 VAC (IC713AE);
Frequency: 47 to 63 Hz;
Consumption: 25 watts;
(A -48-VDC version (IC713A-48) of the Converter is also available; call your supplier for details)
- Size** — 1.8"H x 7.6"W x 9.5"D (4.6 x 19.3 x 24.1 cm)
- Weight** — 3.7 lb (1.7 kg)

2. Introduction

2.1 Functional Description

The G.703 Codirectional Converter converts the CCITT G.703 codirectional interface to standard data-communication interfaces. The Converter can perform two conversions:

- **Electrical Conversion** — from G.703 to CCITT V.35, V.36/V.11 (EIA RS-449/422), X.21/V.11, or EIA RS-530
- **Data-Rate Conversion** — from 64 kbps to 48 or 56 kbps, when required

The electrical and rate conversions enable you to connect DCE devices to PCM transmission equipment.

The Converter is field-selectable for either V.35 or V.11 electrical standards. The interface connector for either V.35 or V.11 is a 25-pin D-type (“DB25”) connector. If you select V.11, you’ll need the appropriate cable to implement the V.36, X.21, or EIA RS-530 standard.

Operating full-duplex at a transmission rate of 64 kbps, the Converter has a range of up to 800 meters ($\frac{1}{2}$ mile) from the PCM equipment. The unit’s receive-timing source is the recovered clock from the CCITT G.703 receive pair. You can

set a jumper to select any one of these transmit-timing sources:

- Recovered clock from the received pair;
- External timing from the V.11 or V.35 digital interface; or
- Internal timing (used only for testing and diagnostics).

Two internal 16-bit buffers accommodate the difference in clocking phase.

Figure 2-1 below shows a typical application of the G.703 Codirectional Converter. The Converter can act as a data-rate adapter, allowing you to connect DTEs running at 48 or 56 kbps to a 64-kbps G.703-interface line. At 48 or 56 kbps, you can set another jumper to select any one of these ways to use the extra bandwidth:

- To guarantee the satisfaction of the “ones density” requirement, by placing a “1” after every seven bits.
- To pass a control signal end-to-end
- As a 1200-bps asynchronous secondary sub-channel for connecting additional DTE units over the same link.

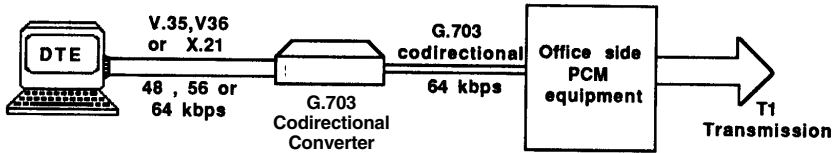

Figure 2-1. Typical G.703 Codirectional Converter application.

The Converter also provides diagnostic capabilities with analog and digital loopbacks. Both loops are activated by the front-panel pushbuttons. You can use the Converter's front-panel LEDs to continuously monitor the main channel's activity and synchronization.

2.2 Timing Theory

2.2.1 CCITT G.703 SIGNALING

The CCITT G.703 codirectional signal is made up of two balanced signals: The **receive** and **transmit signals** carry timing and data information.

The clock signal associated with each direction of transmission travels in the same direction as the data signal (see Figure 2-2).

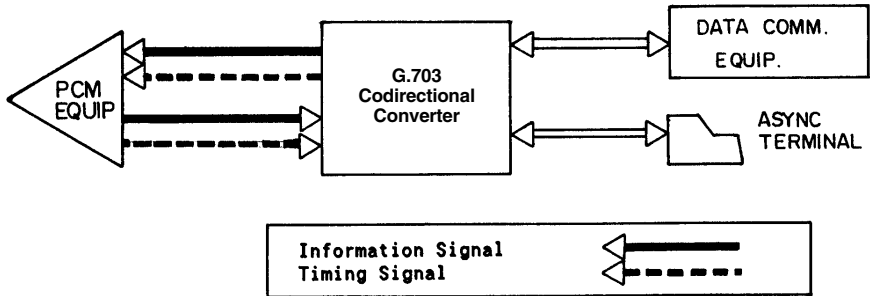

Figure 2-2. G.703 Codirectional Converter signaling.

2.2.2 G.703 CODIRECTIONAL TIMING

The G.703 Codirectional Converter can support virtually all timing options that you might need, as described and illustrated in this section.

G.703 Receive Timing Used for G.703 Transmit Timing

When G.703 receive timing is used for G.703 transmit timing, three timing options for the data-communication side, associated with the loopback timing (LBT) on the G.703 side, are available:

- Receive Clock and Transmit Clock are both outputs from the Converter, which serves as a DCE (see Figure 2-3).
- Receive Clock and Transmit Clock are both inputs to the Converter (with X.21 interface only), which serves as a DTE (see Figure 2-4).
- Receive Clock is an output from the Converter, while Transmit Clock is an input to the Converter from an external DCE, for connection to a tail circuit (see Figure 2-5).

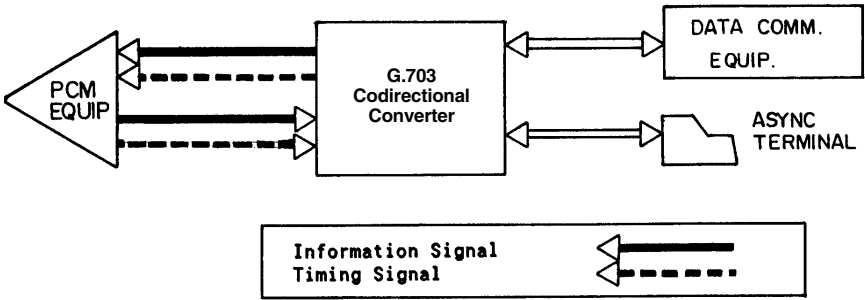

Figure 2-2. G.703 Codirectional Converter signaling.

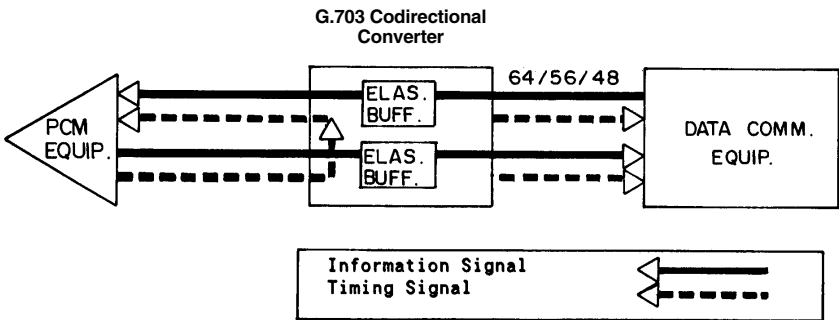

Figure 2-3. LBT-DTE Connection.

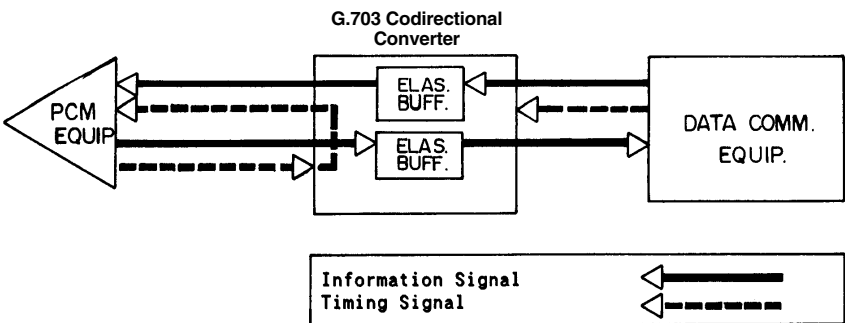

Figure 2-4. LBT-DCE21 Connection.

G.703 CODIRECTIONAL CONVERTER

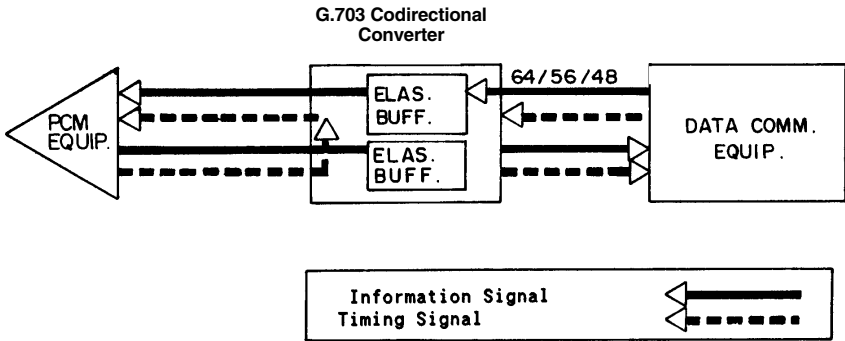

Figure 2-5. LBT-DCE Connection.

Transmit-Clock Timing Mode

When you use the external transmit clock on the data-communications side for G.703 transmit timing, there is complete independence, within the G.703 Codirectional Converter, between the receive and the transmit directions of transmission. Figure 2-6 shows this timing mode.

Internal-Clock Timing Mode

The Converter's internal oscillator is usually used as the source for G.703 transmit timing for testing purposes only, but can also be used with systems that do not have a clock source. Figure 2-7 shows this timing mode.

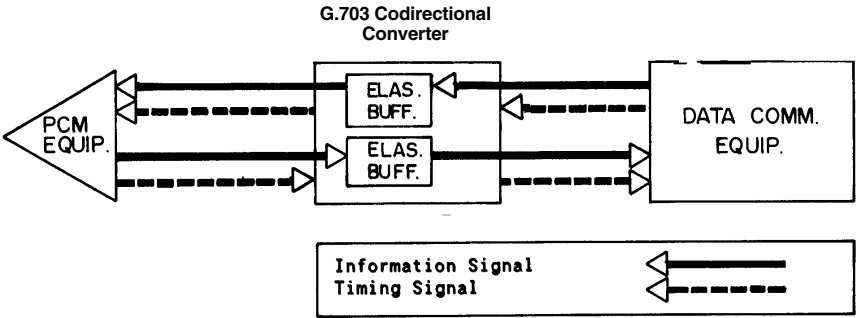

Figure 2-6. Transmit Clock Timing Mode.

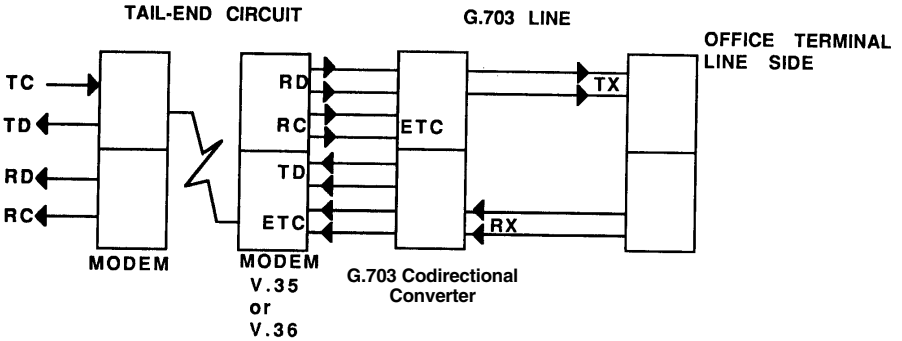

Figure 2-7. Internal Clock Timing Mode.

2.2.3 TAIL-END CLOCKING

Transmit clock from the external DCE source is provided for applications requiring the use of a modem in order to reach a remote DTE, as shown in Figure 2-8 (see Figures A-2, A-7, and A-10 in the **Appendix** for pinouts). Use the LBT-DCE-timing mode with the G.703 Codirectional Converter (see Figure 2-5).

2.2.4 G.703 CODIRECTIONAL RULES

G.703 codirectional signals, in each direction of transmission, are coded as follows: The composite timing/ data signal conveys the 64-kHz bit-timing information, the 8-kHz octet information (by introducing violations into the signal), and the 64-kbps data pattern.

- A binary one (64-kbps bit period) is coded as a block of the four bits “1100.”
- A binary zero (64-kbps bit period) is coded as a block of the four bits “1010.”

The binary signal is converted into a three-level signal by alternating the polarity of the blocks. The alternation of the polarity of the blocks is violated every eight blocks (see Figure 2-9 on the next page).

If necessary, the bit stream from the DTE can be inverted prior to the conversion to G.703. (The binary signal being sent to the DTE is inverted at the same time.) You can turn this data inversion on or off, as appropriate for your application, by setting one of the Converter’s jumpers.

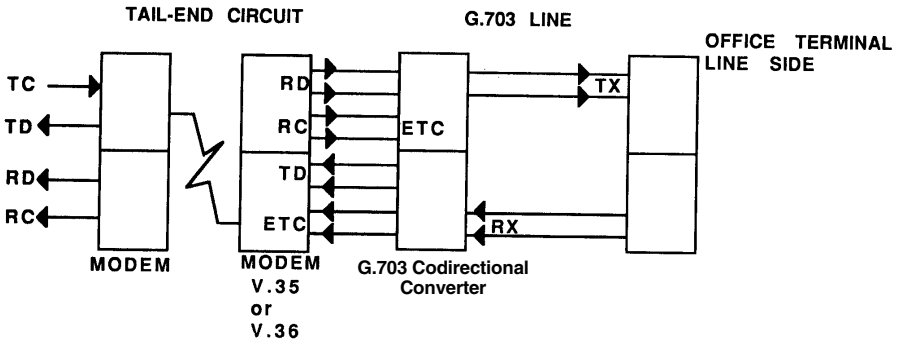

Figure 2-8. Tail Circuit Application.

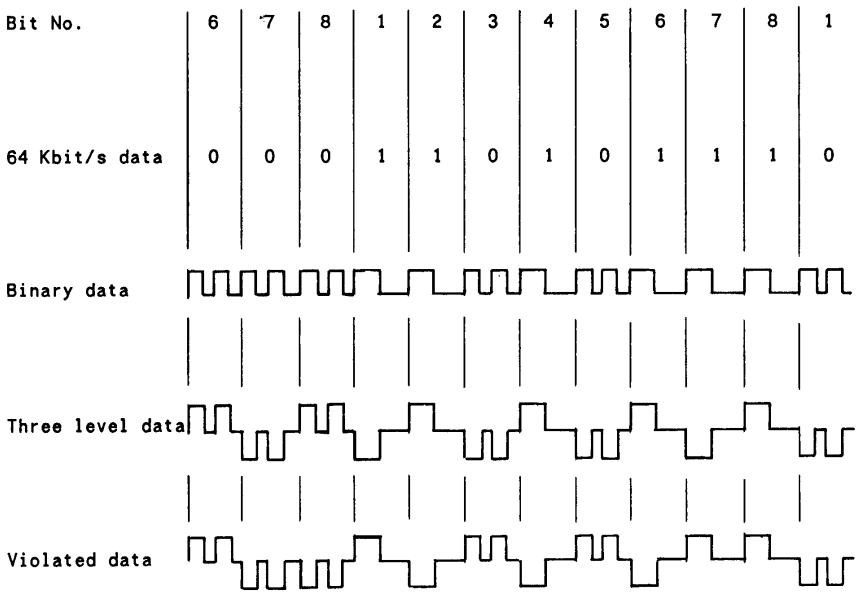

Figure 2-9. G.703 Code Conversion.

2.3 Rate-Conversion Rules

64- to 56-kbps conversion is performed by suppressing bit position number 8. This bit position coincides with the introduced violation (as shown in Figure 2-9), and thus suppressing it conforms to the requirements of CCITT standard V.110 for 56- to 64-kbps rate conversion. The suppressed bit can be used for RTS-DCD end-to-end signalling or for a secondary async channel. North American T1 (1.544-Mbps) applications require that this bit position be set to a binary "1." You can do this easily by leaving the RTS pin open (not connected) and by selecting the data-polarity jumper's MARK = "1" setting.

2.4 Physical Description

The G.703 Codirectional Converter is a standalone unit. The unit is designed for installation on top of a bench or a shelf, but can also be mounted on a 19-inch rack with the proper adapter kit. One or two standalone units can be installed together.

3. Installation

This chapter shows you how to install the G.703 Codirectional Converter. After you complete the installation, refer to **Chapter 4** for operating information.

The G.703 Codirectional Converter is designed for placement on a shelf or bench, and comes completely assembled. With the rackmount-adaptor kit, you can also install it in a 19-inch rack.

3.1 Unpacking

Unpack the equipment this way:

- Carefully take the G.703 Codirectional Converter out of the box it came in and place the Converter on a clean surface.
- Inspect the unit for damage. Immediately report any damage you find to your carrier and supplier.

3.2 Site Requirements

The G.703 Codirectional Converter should be installed within 5 feet (1.5 m) of a grounded AC outlet capable of furnishing 230 or 115 volts. It must be situated within half a mile (800 m) of the PCM equipment.

Make sure that there is at least 4 inches (10 cm) of clearance behind the G.703 Codirectional Converter for signal lines and interface cables.

3.3 Setting Jumpers

3.3.1 OVERVIEW

Prior to installing the G.703 Codirectional Converter, determine its configuration in the data system and set its jumpers accordingly. Refer to Table 3-1. The diagrams in **Chapter 2** can help you identify the required jumper selection. Jumper locations on the printed circuit board are shown in Figure 3-1. Read the instructions in **Section 3.3.2** before making any changes.

G.703 CODIRECTIONAL CONVERTER

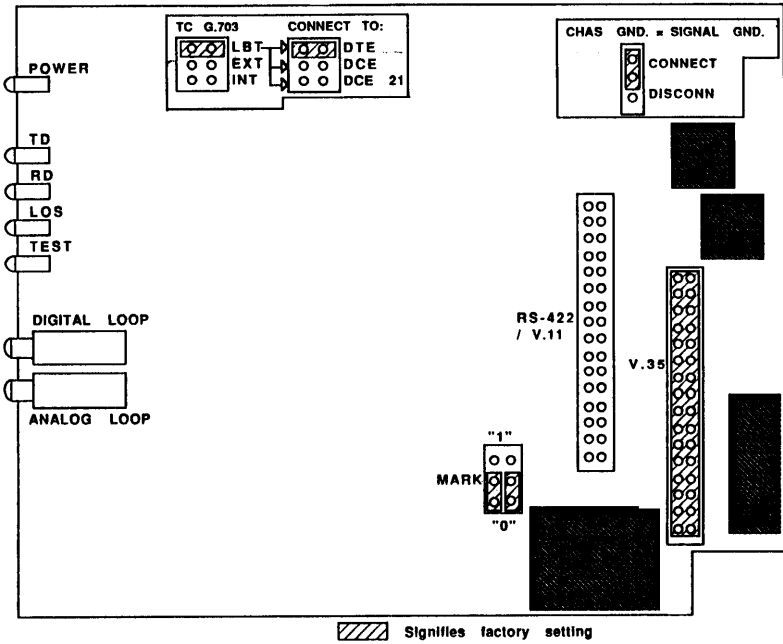

Figure 3-1. G.703 Codirectional Converter Board Layout.

Table 3-1. Jumper Selection.

Jumper Identity	Factory Setting	Possible Position	Function
Interface Board	V.35	V.35 V.11	The interface is CCITT V.35. The interface is EIA RS-449/RS-422, CCITT V.36/V.11, CCITT X.21/V.11, or EIA RS-530.
GND	Disconn	Connect Disconn	Connect: Protective ground connected to signal ground. Disconn: Protective ground disconnected from signal ground.
TC G.703	LBT	LBT EXT INT	The Tx-pair timing is the recovered clock from the CCITT G.703 Rx pair. The Tx-pair and transmit timing are from the RS-422/V.35 external source. The Tx-pair and transmit timing are from the internal source.
LBT	DTE	DTE DCE DCE 21	Connection to DTE, with transmit and receive timing derived from the unit's recovered clock. Connection to DCE, while both the DCE and the unit operate with external transmit timing. Connection to X.21 DCE. The unit's transmit and receive timing are derived from the DCE.
Bit rate	64	64 56 48	Data rate is 64 kbps. Data rate is 56 kbps. Data rate is 48 kbps.
Mark	"0"	"1" "0"	MARK on V.35 or V.11 interface equals "1" on G.703 interface. MARK on V.35 or V.11 interface equals "0" on G.703 interface.

G.703 CODIRECTIONAL CONVERTER

3.3.2 THE JUMPER-SETTING PROCEDURE

CAUTION!

Disconnect the unit from the power line before removing the cover.

WARNING: HIGH VOLTAGE!

Any adjustment, maintenance, and repair of the open instrument under voltage should be avoided as much as possible, and, when inevitable, should be carried out only by a skilled person who is aware of the hazard involved. Capacitors inside the instrument may still be charged even after the instrument has been disconnected from the power source.

To change the settings of any jumpers, perform the following steps:

- Disconnect the AC power cable from the AC mains outlet.
- Remove the top cover of the G.703 Codirectional Converter.
- Identify the jumper(s) (refer to Figure 3-1).
- Move the jumper(s) to your desired position(s).
- Replace the top cover of the G.703 Codirectional Converter.

3.4 Installation in 19-inch Racks

3.4.1 OVERVIEW

The G.703 Codirectional Converter can be installed in 19-inch racks. It is 1U (1.75", 4.4 cm) high and is slightly less than half as wide as the available mounting area. Two rack-adaptor kits are available: One kit provides the hardware necessary to install a single unit, and the other provides the hardware necessary to install two units side by side. **Sections 3.4.2 and 3.4.3** provide step-by-step instructions for installation of single or dual units.

CAUTION!

Disconnect the units from AC power while performing the following procedures.

3.4.2 INSTALLING A SINGLE UNIT IN A 19-INCH RACK

The rack-adapter kit for single-unit installation includes one short bracket and one long bracket. The brackets are fastened with screws to the two side walls of the case, as shown in Figure 3-2.

To prepare the Converter for rack installation, attach the two brackets to the sides of the unit. Do this by inserting screws and flat washers into the two holes at the front of each side (nuts are already in place inside the unit).

After attaching the brackets, install the unit in your 19-inch rack by fastening the brackets to the rack's side rails with four screws (not included in the kit), two on each side.

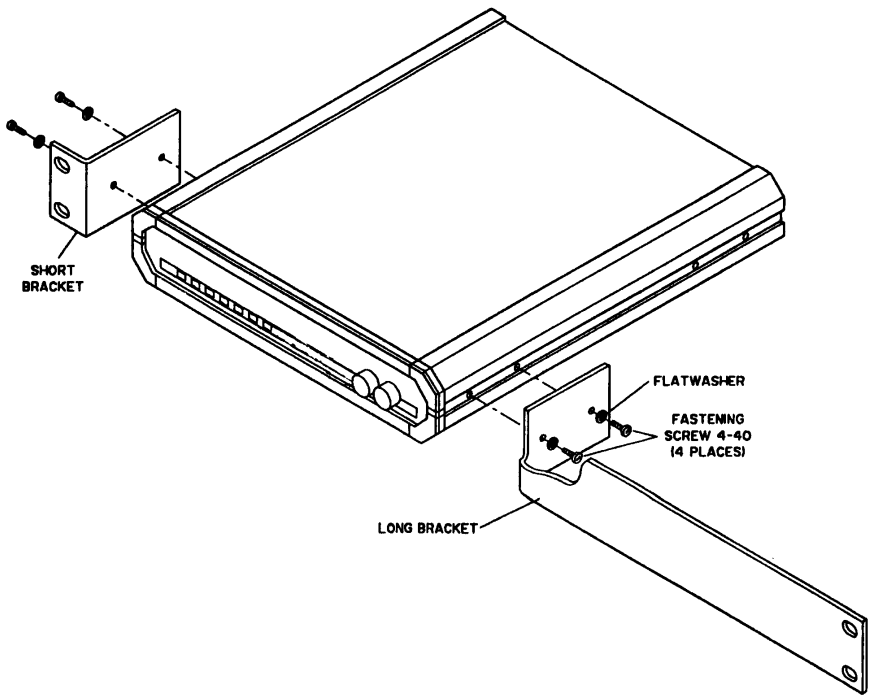

Figure 3-2. Installing a single unit in a 19-inch rack.

3.4.3 INSTALLING TWO UNITS IN A 19-INCH RACK

The adapter kit includes two adapter brackets and various hardware for attaching two Converters side by side in a 19-inch rack. Refer to Figure 3-3 when you perform the following procedure:

1. Remove the cover (item #1 in Figure 3-3) from the unit intended to be on the right-hand side.
2. Position one of the two “U” brackets supplied with the kit (items #2) in the slots inside of the unit’s inner left-hand wall, and align the bracket’s holes with the holes on the wall.
3. Insert flat washers (items #3A) over one pair of long screws (items #3B) and screw the screws through the U bracket (item #2) into the holes on the wall.
4. Repeat steps 2 and 3 above for the other U bracket.
5. Hold the second unit close to the left wall of the opened unit and, using a screwdriver, drive the four long screws (items #3B) until their ends emerge from the first unit’s left wall and engage the holes on the right side of the second unit. Tighten each screw one turn at a time—do not tighten one screw completely before you start to tighten any of the others. Continue to tighten the screws until their heads rest against the U brackets (items #2) and the two Converter units are in contact.
6. Reinstall the cover (item #1) of the first unit (the unit on the right).
7. Fasten one of the two adapter brackets supplied with the kit (items #7A) to the side wall of each unit using the four short screws (items #7B) and four flat washers (items #7C) that are also included.
8. You can now use four screws (*not* supplied with the kit), two on each side, to fasten the assembled units to the side rails of the 19-inch rack.

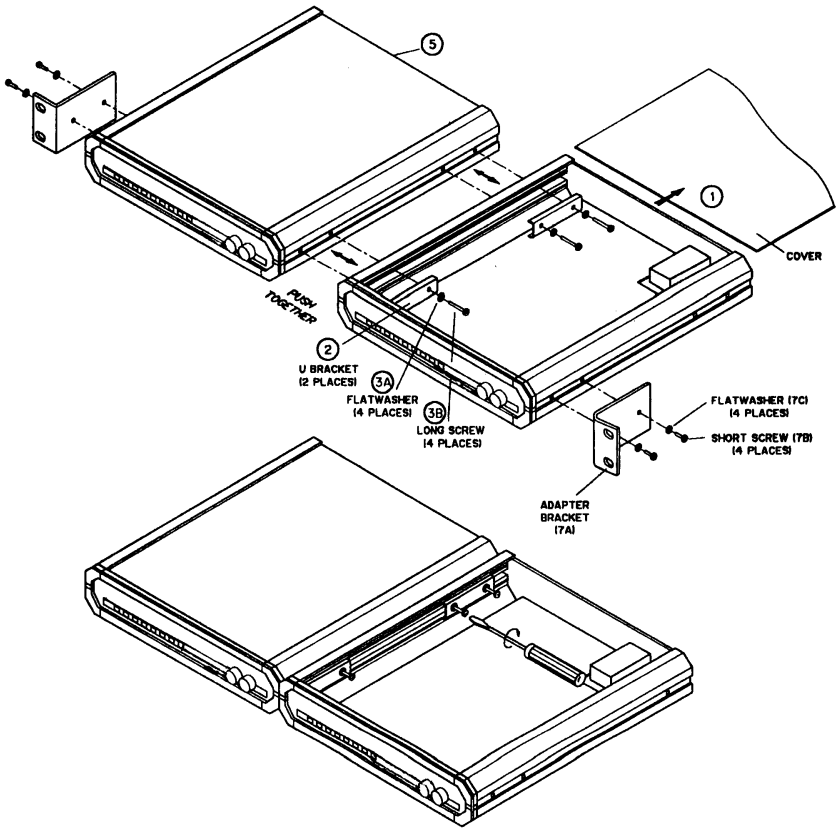

Figure 3-3. Installing two units in a 19-inch rack.

3.5 Connecting Power and Data Cables

After you set the G.703 Codirectional Converter's internal jumpers, the Converter is ready to be cabled for operation.

Its electrical connectors are located on its rear panel, as shown in Figure 3-4. These consist of a DB25 female interface connector labeled "DTE," a 5-screw terminal block labeled "TB," and a 3-prong AC Mains terminal which also contains the integral fuse compartment. The DB25 connector carries input/output data, clock signals, and control signals between the Converter and the DCE (for more detailed information, refer to the **Appendix**). The terminal block has five screws for connecting transmit and receive CCITT G.703 lines—the transmit pair where XMT is indicated, and the receive pair where RCV is indicated.

Connect power and data cables to the Converter as described in the following subsections.

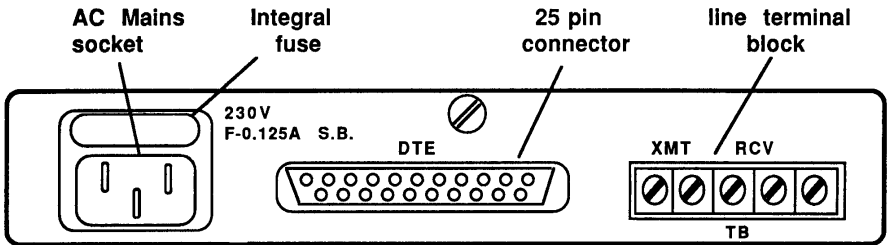

Figure 3-4. Rear panel of the G.703 Codirectional Converter.

3.5.1 POWER CONNECTION

The power connection provides mains power. To make this connection, first attach the IEC 320 female outlet of a standard power cord to the IEC 320 male inlet on the Converter's rear panel. (This power cord must have a standard 3-prong plug on the other end.)

WARNING!

BEFORE PLUGGING THIS UNIT INTO AN OUTLET OR OTHER POWER SOURCE, make sure its protective earth terminals are connected to the protective conductor of the (mains) power cord. The mains plug must be inserted only in a socket outlet provided with a protective earth contact. The protective action must not be negated by use of an extension cord (power cable) without a protective (grounding) conductor.

If the Converter's fuse blows, make sure that you replace it only with a fuse rated for the required amount of current. You must avoid using repaired fuses or short-circuiting the fuse holders. The fuse, and one replacement fuse, are located in the top part of the mains connector on the Converter's rear panel. The nominal current value of the fuse is 0.125 mA for 230-VAC operation.

Whenever it is likely that the protection offered by the fuse has been impaired, the unit must be made inoperative and secured against any unintended operation.

After you have attached the power cord to the unit and have made sure that the cord is properly grounded, you can plug the power cord into a working mains outlet.

CAUTION!

The unit has no power switch. It starts operating as soon as AC power is applied to its POWER connector.

3.5.2 G.703 LINE CONNECTION

The G.703 LINE connection provides an interface for the TX and RX signals between the Converter and G.703 line equipment. To make this connection, attach the wires from the line equipment to the terminal block on the Converter this way:

- XMT + (line equipment) to RCV + (Converter);
- XMT – (line equipment) to RCV – (Converter);
- RCV + (line equipment) to XMT + (Converter);
- RCV – (line equipment) to XMT – (Converter);
- Optional: Ground (line equipment) to ground (Converter—the rightmost terminal).

3.5.3 DTE CONNECTION

The DB25 female DTE connector provides an interface for input/ output data, as well as clock and control signals, between the Converter and a DTE. (The cables and pinning required for different types of DTE connections are shown in the **Appendix**.) To make this connection, run an appropriate cable from the DTE to the Converter and attach the cable's DB25 male connector to the Converter's DTE connector.

3.5.4 ASYNC SECONDARY-CHANNEL CONNECTION

To enable an async secondary channel, you must use a special T-cable which connects both the primary and secondary channels to the Converter through the Converter's DTE connector. Refer to Figures A-3, A-7, and A-11 in the **Appendix**.

NOTE

You can use an async secondary channel only when you run a primary channel at 56 or 48 Kbps on a clear channel, and you must have a G.703 Codirectional Converter at both ends of the link.

The rules for operation with an asynchronous sub-channel are:

- A split (dual) cable should be purchased or prepared. Refer to Figures A-3, A-7, and A-11 in the **Appendix**.
- Signal Ground and Protective Ground are used for the high-speed sync channel as well as for the async channel.
- Pin 8 and Pin 4 can be used to carry only receive and transmit data for the async channel. They cannot be used to carry control signals for the high-speed sync channel.

4. Operation

Besides giving operating instructions, this chapter describes the front-panel controls and LEDs and their functions.

4.1 Front-Panel Controls and LEDs

Five LEDs are visible through the front panel (see Figure 4-1). Each LED's function is described in Table 4-1.

Two pushbuttons are available for activating loops, as described in Table 4-1.

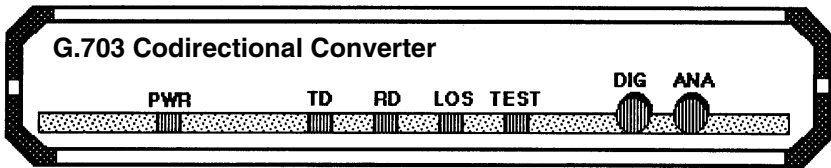

Figure 4-1. Front panel of the G.703 Codirectional Converter.

Table 4-1. Functions of LEDs and Controls.

Indicator/Control	Function
PWR (Green) Power	Lights when the unit is receiving power.
TD (Yellow) Transmit Data	Flickers when data is present at transmit input and goes off when a steady mark is present.
RD (Yellow) Receive Data	Flickers when data is present at receive output and goes off when a steady mark is present.
LOS (Red) Loss of Signal	Lights when the RX pair does not contain the violations required.
TEST (Red) Test	Lights when a loopback is performed.
DIG (Pushbutton)	Activates local digital loopback.
ANA (Pushbutton)	Activates local analog loopback.

4.2 Operating Instructions

The G.703 Codirectional Converter operates unattended once it has been installed and powered up. Intervention is only required when the Converter is set up for the first time, when it must be adapted to new operational requirements, or when diagnostic loops are necessary.

4.2.1 TURN-ON PROCEDURE

The Converter is turned on as soon as power is connected. When power is connected, the PWR LED comes on and remains lit as long as the unit receives power.

If the LOS LED is ON, check the line and make sure it is connected properly.

The TEST LED is ON while either the DIG or ANA pushbutton is depressed, or when Pin 18 in the 25-pin connector is active.

4.2.2 ACTIVATING LOOPS

When performing tests, observe the following guidelines and restrictions:

- Activation of a test loop interrupts normal traffic flow.
- Only one test may be activated at a time.

4.2.3 TURN-OFF PROCEDURE

The Converter can be turned off only by disconnecting its power.

NOTE

Always disconnect the power cord from the AC outlet before you disconnect it from the Converter.

4.3 Diagnostic Loops

Local analog loopback or local digital loopback can be activated by depressing the front-panel pushbutton labeled ANA or DIG respectively. Local analog loopback can also be activated from the local DTE through Pin 18.

Activating local analog loopback causes a loop in the local G.703-interface circuit, towards the local data equipment (as shown in Figure 4-2).

Activating local digital loopback causes a loop in the local unit on the DCE-interface circuitry, towards the G.703 interface (as shown in Figure 4-3).

G.703 CODIRECTIONAL CONVERTER

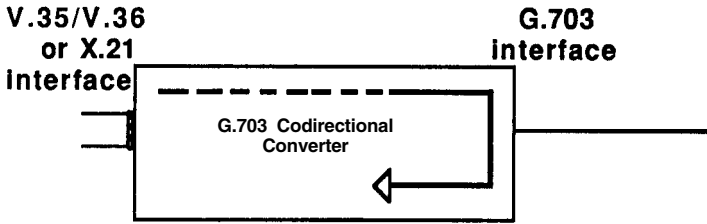

Figure 4-2. Local analog loopback.

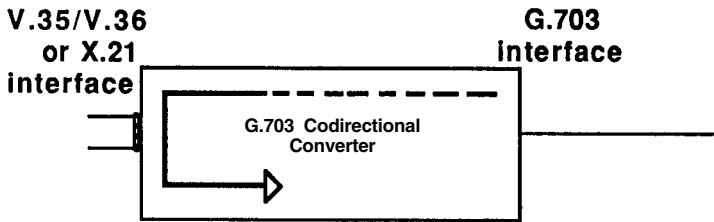

Figure 4-3. Local digital loopback.

Appendix: Pinouts

Figures A-1 to A-11 provide connection diagrams for the range of available interfaces and options. Table A-1 provides pin assignments for cable connections.

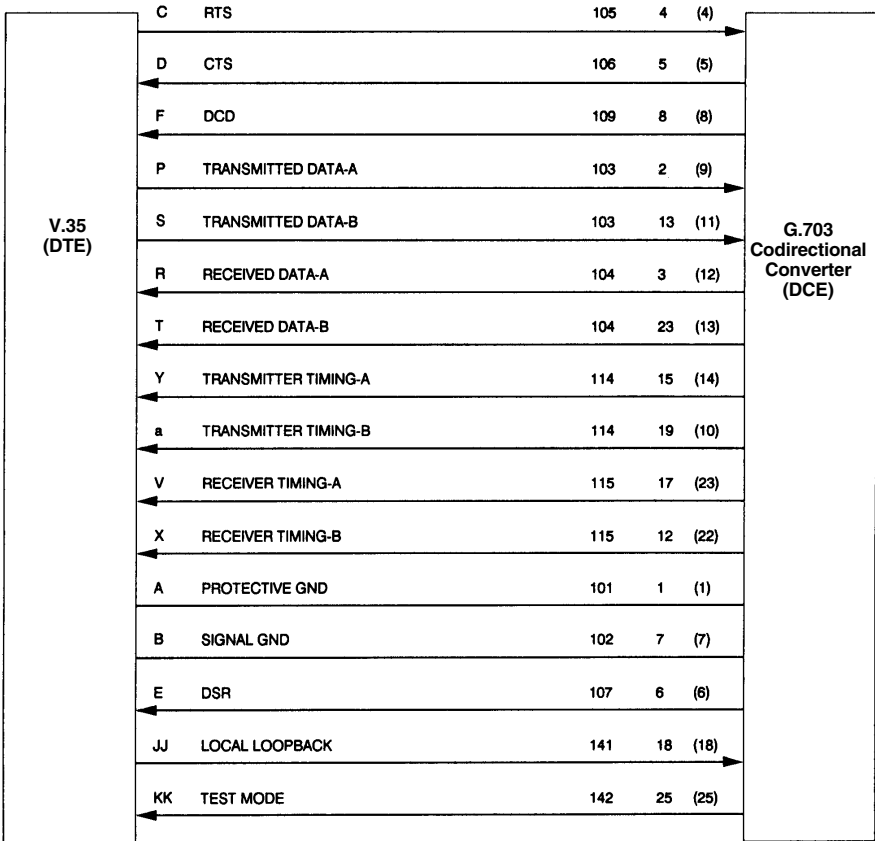

Figure A-1. Connection to DTE, V.35 Interface (EHN033).

G.703 CODIRECTIONAL CONVERTER

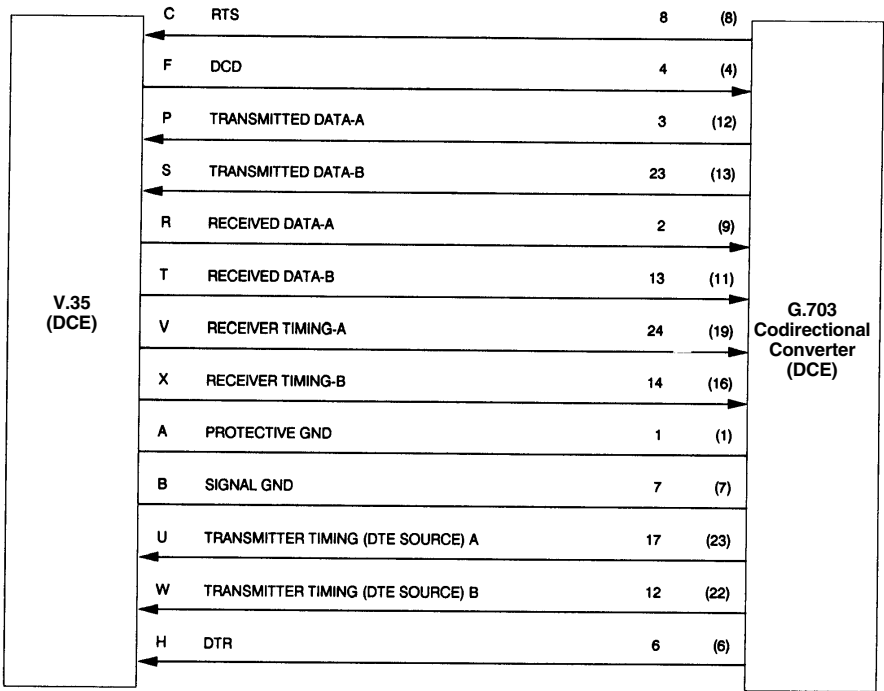

Figure A-2. Connection to DCE, V.35 Interface (for tail circuit application) (EHN034).

G.703
Codirectional
Converter
V.35 25-Pin
Connector

DTE
V.35
Connector

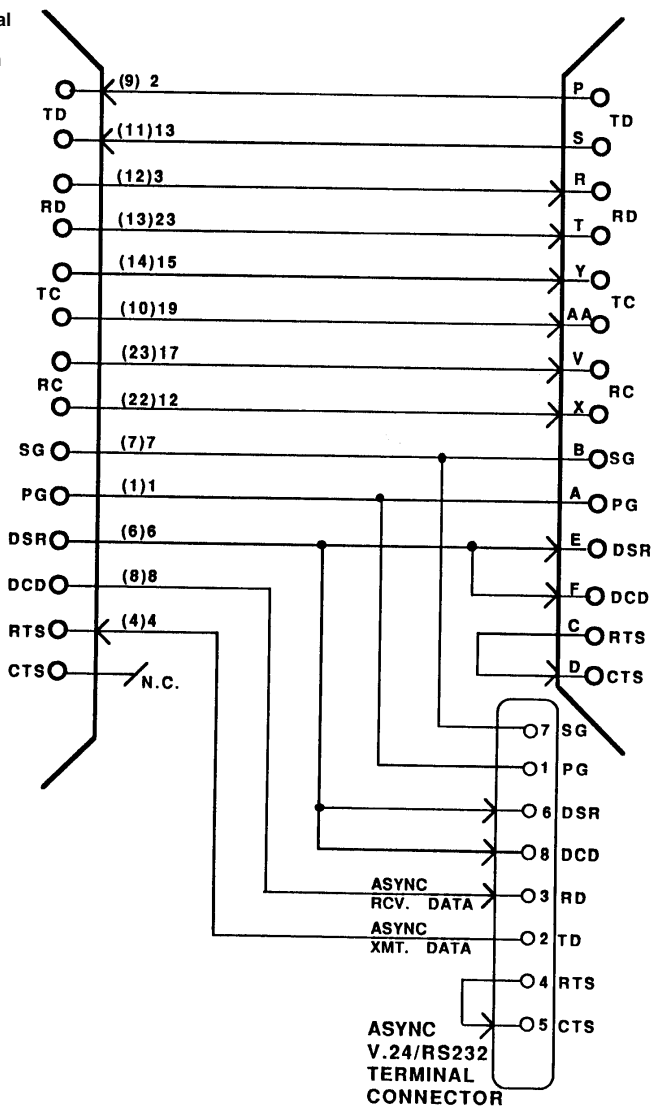

Figure A-3. V.35 With Secondary Channel Cable (EY-2364-C).

G.703 CODIRECTIONAL CONVERTER

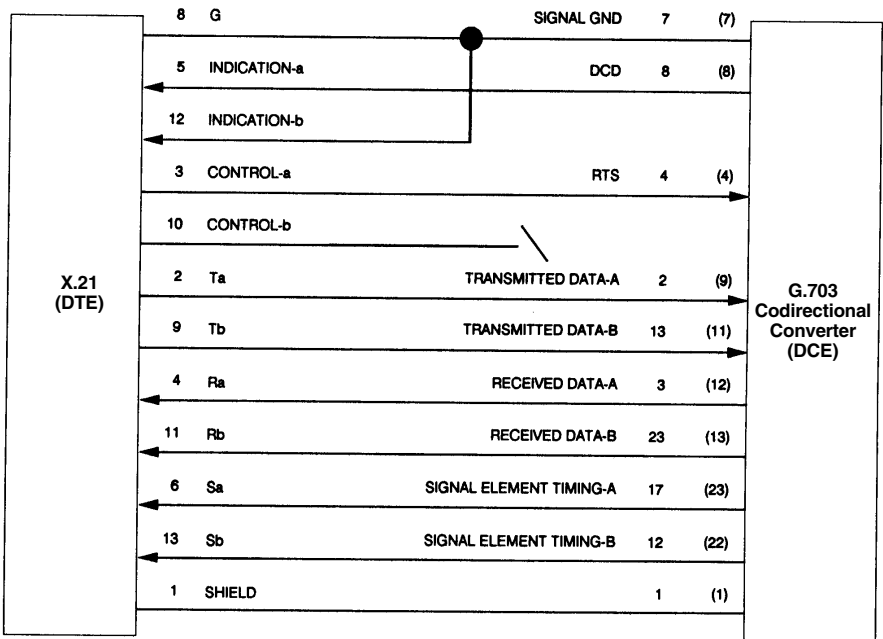

Figure A-4. Connection to DTE, X.21 Interface (EHN035).

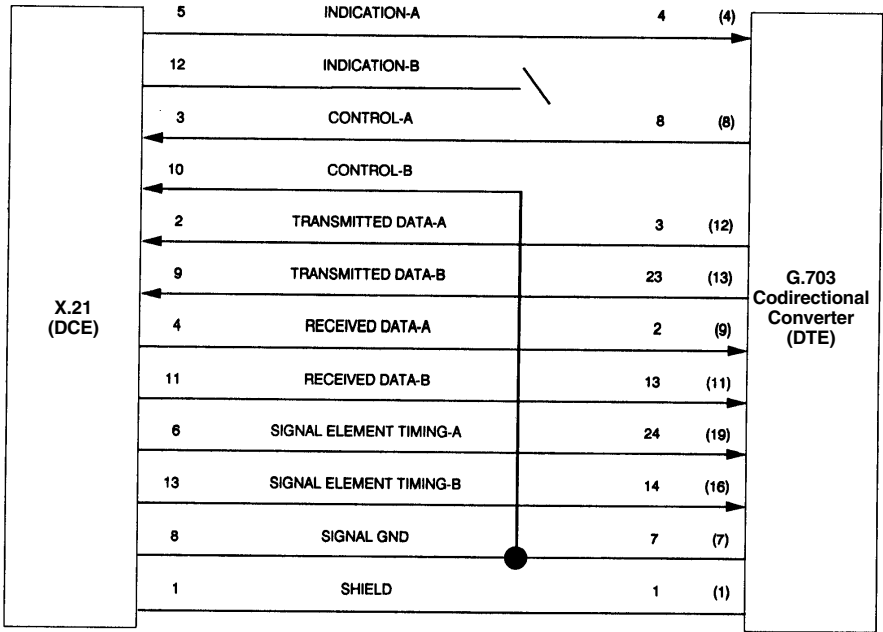

Figure A-5. Connection to DCE, X.21 Interface (EHN036).

G.703 CODIRECTIONAL CONVERTER

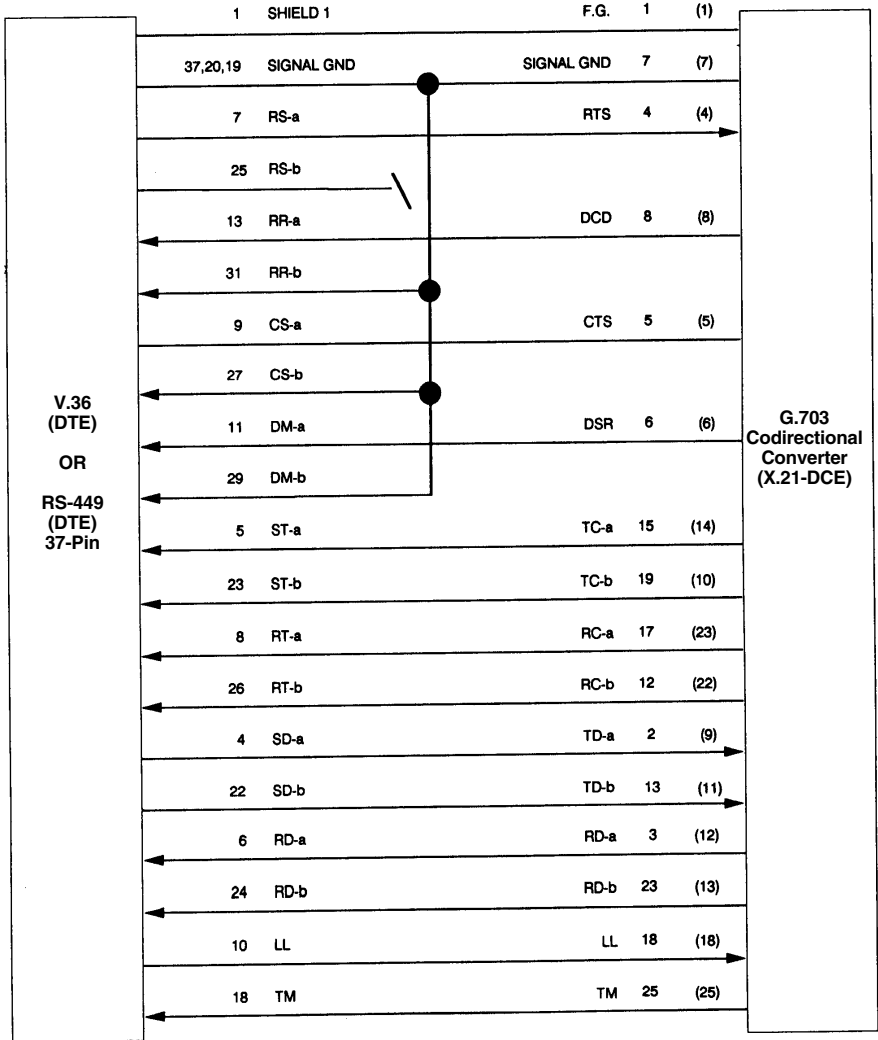

Figure A-6. Connection to DTE, V.36/V.11 Interface (connection to DTE, RS-449/RS-422 interface) (EHN037).

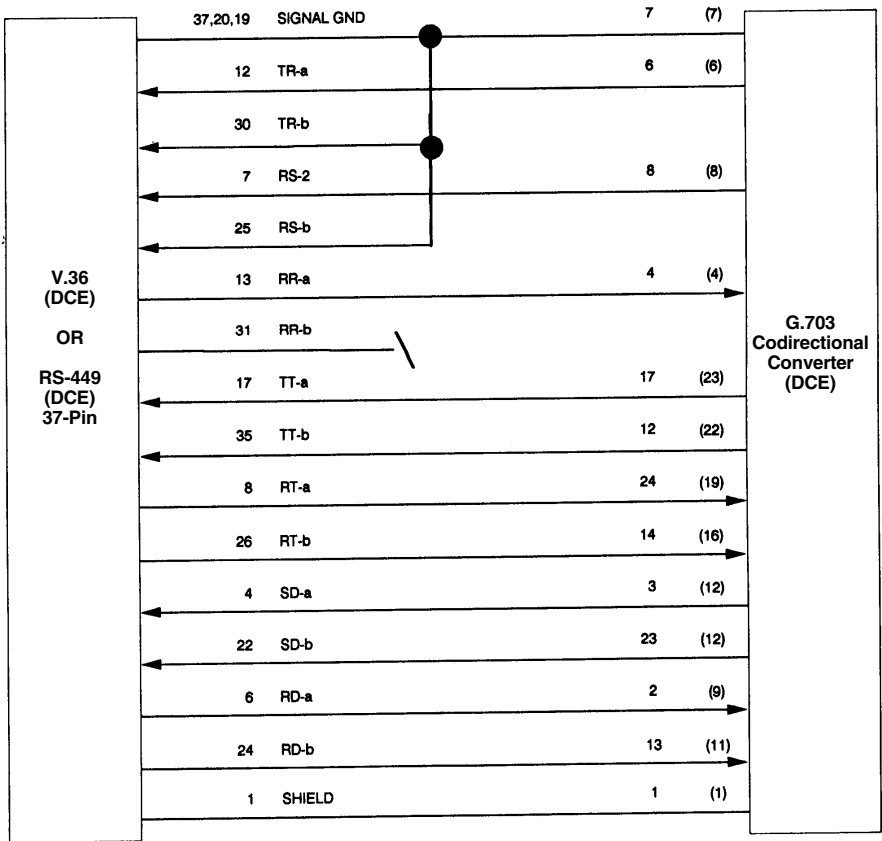

Figure A-7. Connection to DCE, V.36/V.11 Interface
 (connection to DCE, RS-449/RS-422 interface
 for tail circuit application) (EHN038).

G.703 CODIRECTIONAL CONVERTER

G.703
Codirectional
Converter
V.11
25-Pin
Connector

DTE
V.36
Connector

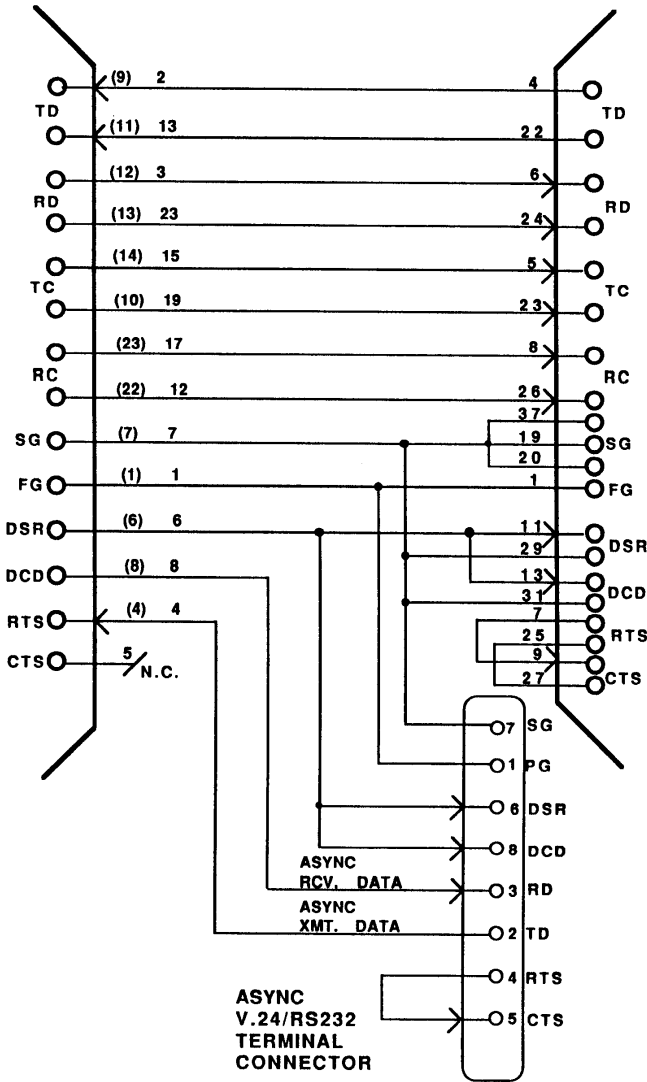

Figure A-8. V.36 With Secondary Channel Cable (EY-2364-B).

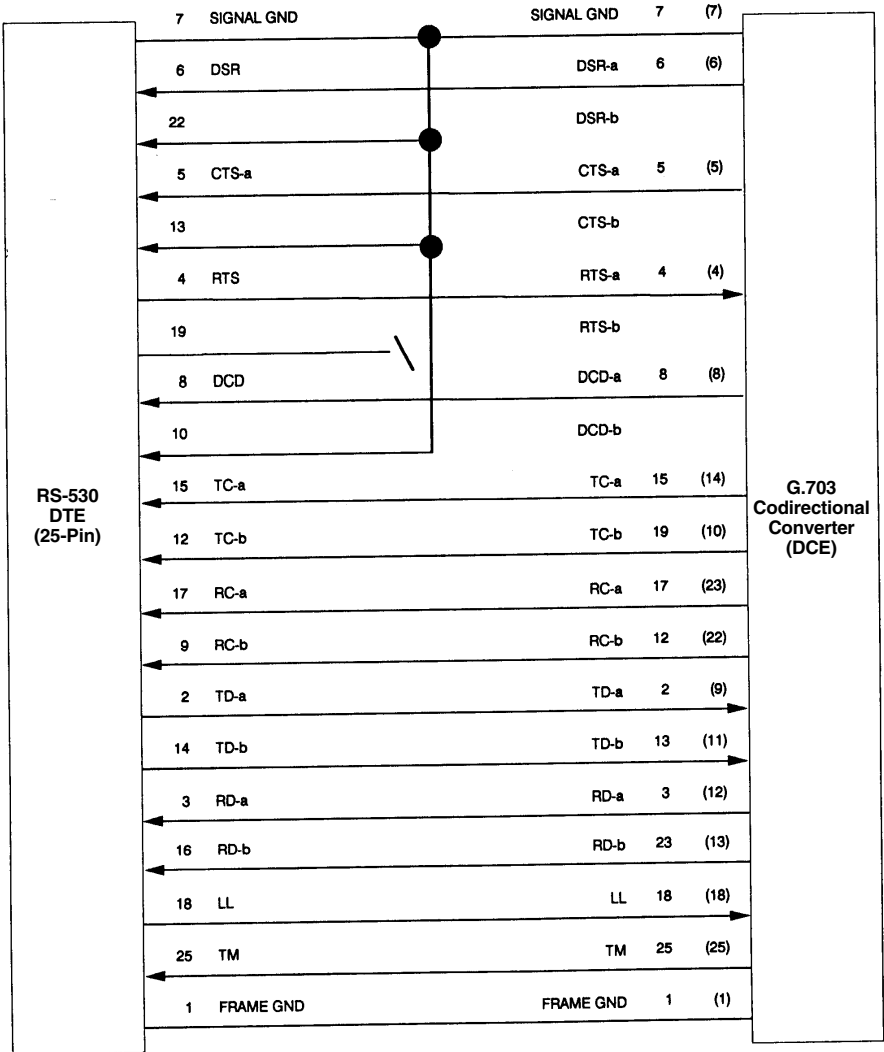

Figure A-9. Connection to DTE, RS-530 Interface (EHN039).

G.703 CODIRECTIONAL CONVERTER

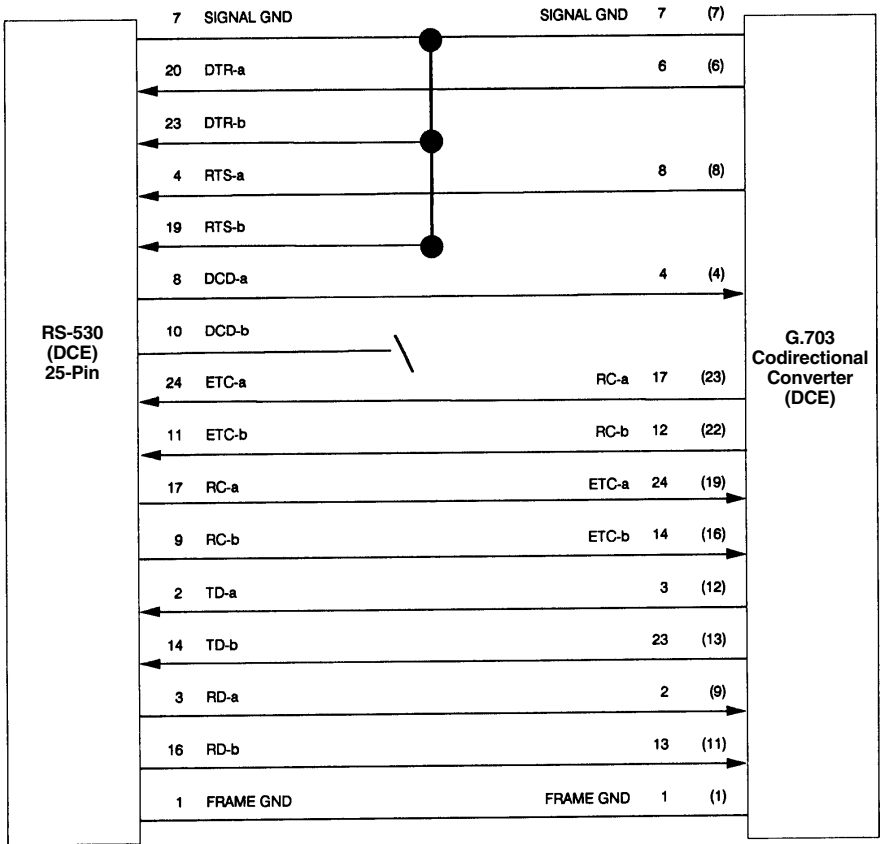

Figure A-10. Connection to DCE, RS-530 Interface (for tail circuit application) (EHN040).

G.703
Codirectional
Converter
V.11
25-Pin
Connector

DTE
RS-530
Connector

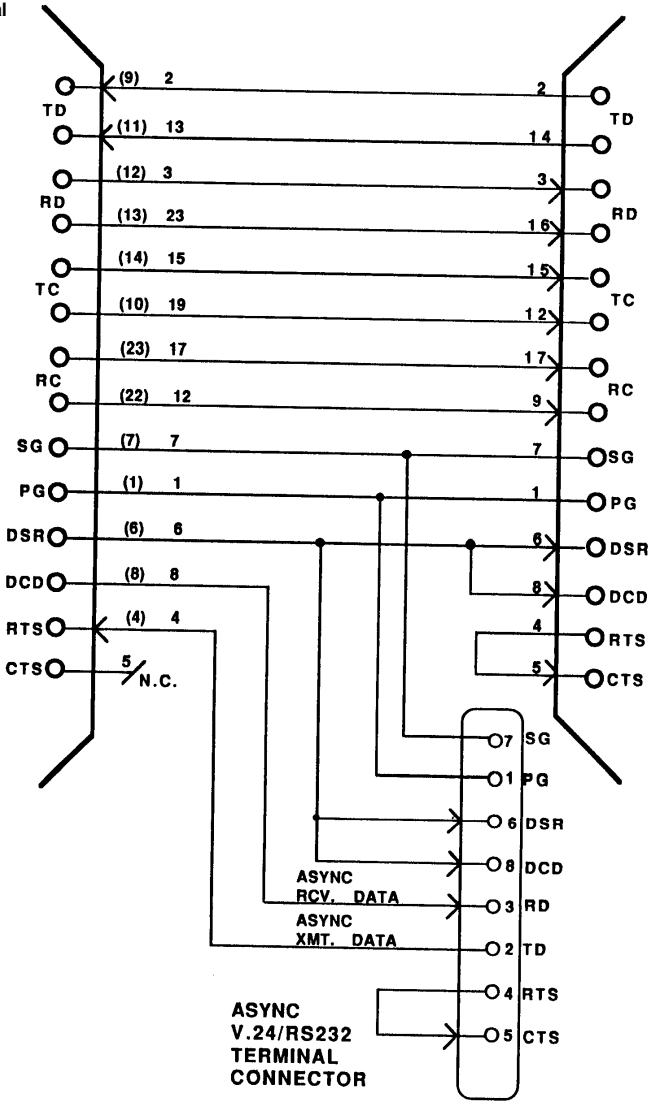

Figure A-11. RS-530 With Secondary Channel Cable (EY-2364-D).

G.703 CODIRECTIONAL CONVERTER

Table A-1. Cable Connections.

Function	IC713 25-PIN	RS-449 DTE 37-PIN	RS-449 DCE 37-PIN	V.35 DTE 34-PIN	V.35 DCE 34-PIN	X.21 DTE 15-PIN	X.21 DCE 15-PIN
Frame Ground	1 (1)	1	1	A	A	1	1
Signal Ground	7 (7)	19,20,37	19,20,37	B	B	8	8
TX Data A	2 (9)	4	6	P	R	2	4
TX Data B	13 (11)	22	24	S	T	9	11
RX Data A	3 (12)	6	4	R	P	4	2
RX Data B	23 (13)	24	22	T	S	11	9
TX Clock A	15 (14)	5	-	Y	-	-	-
TX Clock B	19 (10)	23	-	AA/a	-	-	-
Rx Clock A	17 (23)	8	17	V	U	6	-
RX Clock B	12 (22)	26	35	X	W	13	-
Terminal Timing A	24 (19)	-	8	-	V	-	6
Terminal Timing B	14 (16)	-	25	-	X	-	13
RTS	4 (4)	7	13	C	F	3	5
CTS	5 (5) 7 (7)	9 27	- -	D -	- -	- -	- -
DSR	6 (6) 7 (7)	11 29	12 30	E -	H -	- -	- -
DCD	8 (8) 7 (7)	13 31	7 25	F -	C -	5 12	3 10
Local Loop	18 (18)	10	-	JJ	-	-	-
Test Indicator	25 (25)	18	-	KK	-	-	-



© Copyright 1995. Black Box Corporation. All rights reserved.

1000 Park Drive • Lawrence, PA 15055-1018 • 724-746-5500 • Fax 724-746-0746