

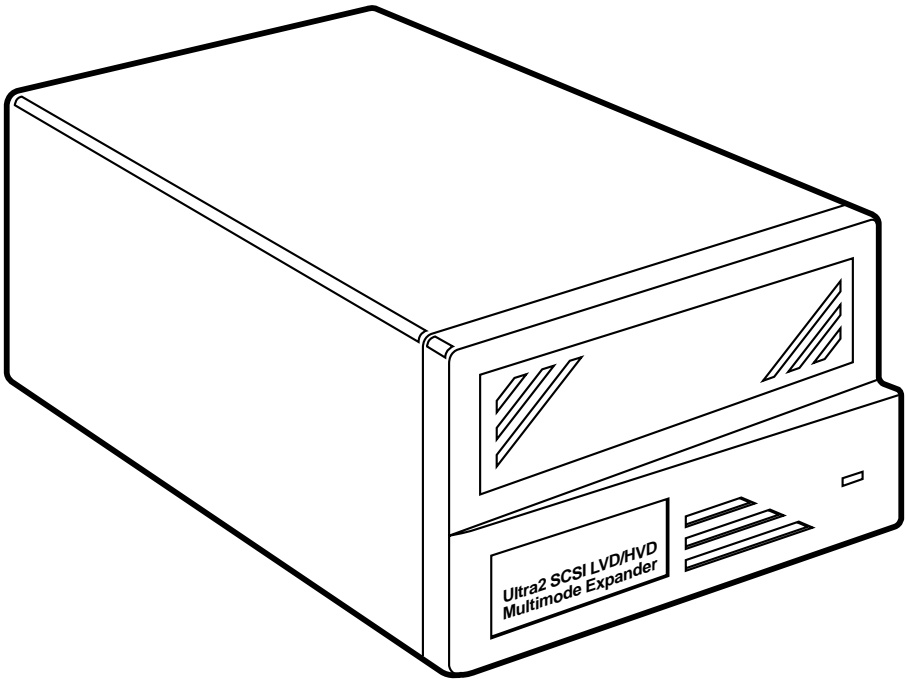

© Copyright 2000. Black Box Corporation. All rights reserved.

1000 Park Drive • Lawrence, PA 15055-1018 • 724-746-5500 • Fax 724-746-0746

Ultra 2 SCSI LVD/HVD Multimode Expander



**CUSTOMER
SUPPORT
INFORMATION**

Order **toll-free** in the U.S. 24 hours, 7 A.M. Monday to midnight Friday: **877-877-BBOX**
FREE technical support, 24 hours a day, 7 days a week: Call **724-746-5500** or fax **724-746-0746**
Mail order: **Black Box Corporation**, 1000 Park Drive, Lawrence, PA 15055-1018
Web site: www.blackbox.com • E-mail: info@blackbox.com

FEDERAL COMMUNICATIONS COMMISSION AND INDUSTRY CANADA RADIO-FREQUENCY INTERFERENCE STATEMENTS

Class B Digital Device. This equipment has been tested and found to comply with the limits for a Class B computing device pursuant to Part 15 of the FCC Rules. These limits are designed to provide reasonable protection against harmful interference in a residential installation. However, there is no guarantee that interference will not occur in a particular installation. This equipment generates, uses, and can radiate radio frequency energy, and, if not installed and used in accordance with the instructions, may cause harmful interference to radio communications. If this equipment does cause harmful interference to radio or telephone reception, which can be determined by turning the equipment off and on, the user is encouraged to try to correct the interference by one of the following measures:

- Reorient or relocate the receiving antenna.
- Increase the separation between the equipment and receiver.
- Connect the equipment into an outlet on a circuit different from that to which the receiver is connected.
- Consult an experienced radio/TV technician for help.

Caution:

Changes or modifications not expressly approved by the party responsible for compliance could void the user's authority to operate the equipment.

This digital apparatus does not exceed the Class B limits for radio noise emission from digital apparatus set out in the Radio Interference Regulation of Industry Canada.

Le présent appareil numérique n'émet pas de bruits radioélectriques dépassant les limites applicables aux appareils numériques de la classe B prescrites dans le Règlement sur le brouillage radioélectrique publié par Industrie Canada.

**NORMAS OFICIALES MEXICANAS (NOM)
ELECTRICAL SAFETY STATEMENT**

INSTRUCCIONES DE SEGURIDAD

1. Todas las instrucciones de seguridad y operación deberán ser leídas antes de que el aparato eléctrico sea operado.
2. Las instrucciones de seguridad y operación deberán ser guardadas para referencia futura.
3. Todas las advertencias en el aparato eléctrico y en sus instrucciones de operación deben ser respetadas.
4. Todas las instrucciones de operación y uso deben ser seguidas.
5. El aparato eléctrico no deberá ser usado cerca del agua—por ejemplo, cerca de la tina de baño, lavabo, sótano mojado o cerca de una alberca, etc.
6. El aparato eléctrico debe ser usado únicamente con carritos o pedestales que sean recomendados por el fabricante.
7. El aparato eléctrico debe ser montado a la pared o al techo sólo como sea recomendado por el fabricante.
8. Servicio—El usuario no debe intentar dar servicio al equipo eléctrico más allá a lo descrito en las instrucciones de operación. Todo otro servicio deberá ser referido a personal de servicio calificado.
9. El aparato eléctrico debe ser situado de tal manera que su posición no interfiera su uso. La colocación del aparato eléctrico sobre una cama, sofá, alfombra o superficie similar puede bloquea la ventilación, no se debe colocar en libreros o gabinetes que impidan el flujo de aire por los orificios de ventilación.
10. El equipo eléctrico deber ser situado fuera del alcance de fuentes de calor como radiadores, registros de calor, estufas u otros aparatos (incluyendo amplificadores) que producen calor.
11. El aparato eléctrico deberá ser conectado a una fuente de poder sólo del tipo descrito en el instructivo de operación, o como se indique en el aparato.

12. Precaución debe ser tomada de tal manera que la tierra física y la polarización del equipo no sea eliminada.
13. Los cables de la fuente de poder deben ser guiados de tal manera que no sean pisados ni pellizcados por objetos colocados sobre o contra ellos, poniendo particular atención a los contactos y receptáculos donde salen del aparato.
14. El equipo eléctrico debe ser limpiado únicamente de acuerdo a las recomendaciones del fabricante.
15. En caso de existir, una antena externa deberá ser localizada lejos de las líneas de energía.
16. El cable de corriente deberá ser desconectado del cuando el equipo no sea usado por un largo periodo de tiempo.
17. Cuidado debe ser tomado de tal manera que objetos líquidos no sean derramados sobre la cubierta u orificios de ventilación.
18. Servicio por personal calificado deberá ser provisto cuando:
 - A: El cable de poder o el contacto ha sido dañado; u
 - B: Objetos han caído o líquido ha sido derramado dentro del aparato; o
 - C: El aparato ha sido expuesto a la lluvia; o
 - D: El aparato parece no operar normalmente o muestra un cambio en su desempeño; o
 - E: El aparato ha sido tirado o su cubierta ha sido dañada.

Contents

Chapter	Page
1. Specifications	5
2. Introduction	6
2.1 Overview	6
2.2 Features	8
2.3 The Complete Package	8
3. Configuration and Internal LEDs	9
3.1 Opening the Expander	9
3.2 Configuring Termination	11
4. Installation	14
4.1 Connecting the SCSI-Bus Cables	14
4.2 Connecting AC Power and Observing the External LEDs	15
5. Applications	16
5.1 Applications That Will Work	16
5.2 Applications That Won't Work	18
6. Troubleshooting	19
6.1 Calling Black Box	19
6.2 Shipping and Packaging	19
Appendix A: Port Pinouts	20
A.1 High-Voltage Differential (HVD) Pinout	20
A.2 Low-Voltage Differential (LVD) Pinout	20
A.3 Single-Ended (SE) Pinout	22
Appendix B: Block Diagram	24

1. Specifications

Compliance —	FCC Part 15 Subpart J Class B, IC Class/classe B
Interfaces —	LVD/SE port: Wide (16-bit) Ultra2 SCSI (“Fast 40”), multimode (can be either LVD or single-ended, autosensing); HVD port: Wide (16-bit) Ultra SCSI, high-voltage differential
Protocol —	Transparent to synchronous or asynchronous communication
Data Rate —	LVD: Up to 80 Megabytes per second
Maximum Distance —	Can extend HVD SCSI bus as far as 37 m (121.3 ft.)
User Controls —	(4) Internal jumpers for termination
Indicators —	(2) Front-mounted LEDs: Power and Busy
Connectors —	(2) Micro D68 female (see Appendix A for pinouts)
Power —	110 to 220 VAC, 50 to 60 Hz (autosensing)
Size —	2.9"H x 4.8"W x 7.8"D (7.4 x 12.2 x 19.8 cm)
Weight —	3.3 lb. (1.5 kg)

2. Introduction

2.1 Overview

The Ultra2 SCSI LVD/HVD Multimode Expander is a 16-bit Wide SCSI Low Voltage Differential (LVD) to High Voltage Differential (HVD) converter. The Expander effectively divides the SCSI bus into one LVD or SE (single-ended) segment (connected to its “LVD/SE” port) and an HVD segment (connected to its “HVD” port). The Expander translates signals, and facilitates communication, between the segments.

When used in conjunction with an Ultra2 SCSI host adapter, the Expander maintains backward compatibility with previous generations of devices on HVD segments, while retaining the optimal performance and maximum cable length of LVD. The Expander can also be used with an Ultra SCSI (“SCSI-3,” 40-MB-per-second) HVD host adapter to add Ultra2 devices to its bus. Because it performs only signal-level translation, the Expander operates transparently; users will hardly know it’s there. It places no limits on the quantity or location of SCSI devices beyond the normal limits of the SCSI specification.

The Expander’s LVD/SE port is “multimode,” meaning it can operate in either single-ended or LVD mode. (This selection is controlled automatically by a sensing signal [DIFFSENSE] provided by the SCSI devices on the bus. As soon as you connect it to the bus, the Expander will autoconfigure its ports as necessary.)

The Expander supports all current SCSI operations and can handle data rates up to 20, 40, or 80 megabytes per second, depending on the type of bus it's communicating with. Figure 2-1 shows a typical Expander application. If you'd like to examine a block diagram of the Expander, refer to **Appendix B**.

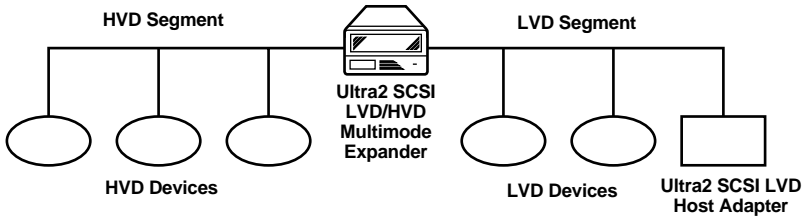

Figure 2-1. One SCSI bus with two physical segments: Using an Expander to access legacy HVD devices with an LVD host adapter.

2.2 Features

- Supports legacy and Ultra2 SCSI devices on the same bus with LVD-to-HVD or SE-to-HVD conversion:
 - Fully backward-compatible with SCSI-1, SCSI-2 [Fast SCSI], and SCSI-3 [Ultra SCSI], and can be used with either Narrow or Wide buses.
 - Has switchable internal termination.
- Transfers data at up to 80 Megabytes per second (on a 16-bit Wide bus) in either direction.
- Supports as many as 16 SCSI devices.
- Does not require software or a SCSI ID.
- Has RS-485 HVD transceivers.
- Can be used to extend your HVD bus as far as 37 m (121.3 ft.).
- Transparent operation—requires no software and no SCSI ID.
- Supports arbitration, parity, disconnect/reconnect, and sync or async data transfer.
- Can act as either a target or initiator on either connected SCSI-bus segment.
- LEDs show power status and bus activity at all times.
- Can optionally provide TERMPWR (terminator power) to either or both attached bus segments. Handles TERMPWR with a resetting circuit protector and backflow-preventing diodes.

2.3 The Complete Package

Besides the Ultra2 SCSI LVD/HVD Multimode Expander itself, you should have received its power cord and this manual. If anything is missing or arrived damaged, call Black Box right away.

3. Configuration and Internal LEDs

3.1 Opening the Expander

To configure the Ultra2 SCSI LVD/HVD Multimode Expander's termination, you'll need to access the Expander's internal jumpers.

CAUTION!

To avoid receiving a potentially hazardous electric shock, make sure the Expander is turned OFF and unplugged both when you open it and for the entire period of time it stays open.

Conversely, even while the Expander is OFF, you need to avoid damaging its circuit board with static electricity. If possible, stand on an anti-static mat when you open the Extender and wear anti-static gloves or wrist straps. At the very least, ground yourself before you open the Expander by touching something metal.

Take these steps to open the Expander:

1. Use a small Phillips-head screwdriver to unscrew the screws embedded in each of the Expander's four rubber feet. Remove the feet.
2. You'll see the edges of the Expander's wraparound housing on the bottom of the unit right next to the holes where the feet used to be. If necessary, gently pry one of these edges slightly outward so that the housing doesn't fit so snugly.
3. Carefully slide the housing toward the back of the unit and remove it.

ULTRA2 SCSI LVD/HVD MULTIMODE EXPANDER

Now you're ready to set the jumpers. If you look at the open Expander from above, with its front panel facing right and its rear panel facing left, the jumper posts and internal LEDs will be arranged at the top and bottom edges of the circuit board, something like this:

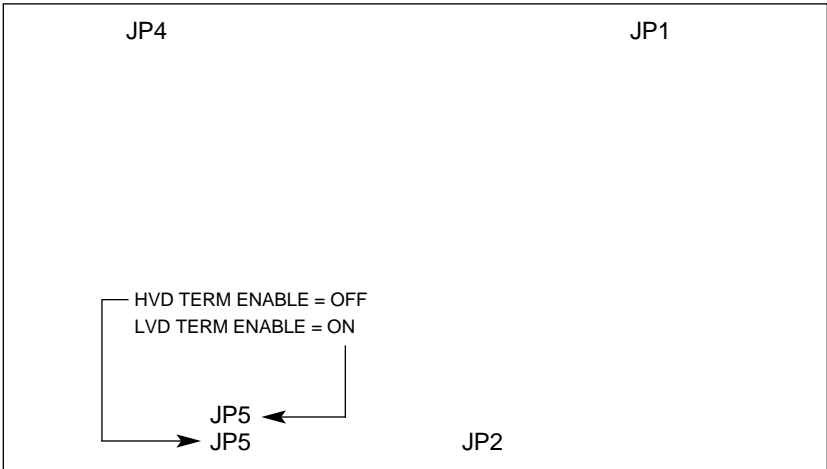

A jumper will be on *the upper pair of posts* at JP5 (it's a four-position jumper); two wires going to the external LED will be connected to JP2. All other jumper posts will be empty. (JP4 might be hidden beneath the circuit board's internal power-cord connectors.)

Jumper posts JP1, JP4, and JP5 control termination; their possible settings are described in **Section 3.2**. The JP2 jumper posts form the electrical connection to the external Busy LED; don't disturb this connection.

3.1 Configuring Termination

Both ends of any SCSI-bus segment attached to the Expander need to be terminated in order to prevent electronic “echo” interference on the bus that would degrade its performance. You can use the Expander’s internal jumpers JP1, JP4, and JP5 to control this termination. JP1 and the *lower posts* of JP5 affect the bus attached to the HVD port, while JP4 and the *upper posts* of JP5 affect the bus attached to the LVD/SE port.

- **Termination at the Expander (JP5):** How you should set jumpers on the four posts at JP5, which control local termination at the Expander’s ports, depends on how your cables will be attached to the Expander. Just remember that the upper and lower JP5 posts have *opposite* values: For the lower (HVD) posts, OFF (empty) is terminated and ON (installed) is unterminated; for the upper (LVD/SE) posts, ON is terminated and OFF is unterminated.

- For each port into which you will be directly plugging a single cable, so that the SCSI-bus segment will *start or end* at that port, leave the jumper positions just as they come from the factory. If a segment will start or end at the HVD port, leave the jumper OFF the lower posts. If a segment will start or end at the LVD/SE port, leave the jumper ON the upper posts.

Example: For simple conversion applications in which an LVD bus ends at the Expander and an HVD bus starts, or vice versa, leave the jumpers installed on upper JP5 and leave lower JP5 empty.

- For each port into which you will be plugging two cables through a three-connector adapter (*not a stub cable!*), so that the SCSI-bus segment will *pass through* that port, remove the jumper. If a segment will pass through the HVD port, *install* a jumper on the lower posts. If a segment will pass through the LVD/SE port, *remove* the jumper from the upper posts.

Example: For applications in which you are allowing a segment of HVD devices to tap into an LVD bus without forcing the LVD bus to operate at the data rate of the HVD segment, remove the jumper from upper JP5. If the HVD segment ends at the Expander, leave the lower JP5 jumper posts empty. But if the HVD segment also passes through the Expander, install a jumper on the lower JP5 posts.

Refer to Figures 3-1 through 3-3 on the next page. In an application such as that shown in Figure 3-1, lower JP5 should remain empty and upper JP5 should remain installed. In an application like that in Figure 3-2, with the Expander in the middle of one segment and at the end of another, set the jumper oppositely for the port that’s attached to the middle of the segment. In a wide-open application like that in Figure 3-3, in which the Expander is in the middle of both segments, remove the jumper from upper JP5 and install it on lower JP5.

ULTRA2 SCSI LVD/HVD MULTIMODE EXPANDER

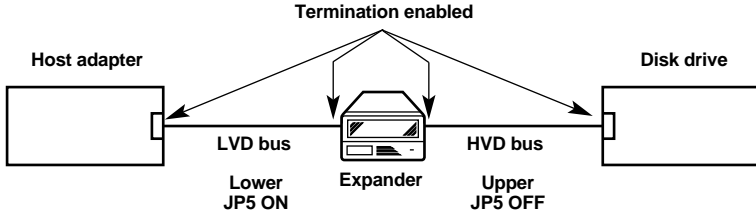

Figure 3-1. Both segments end, and are terminated, at the Expander.

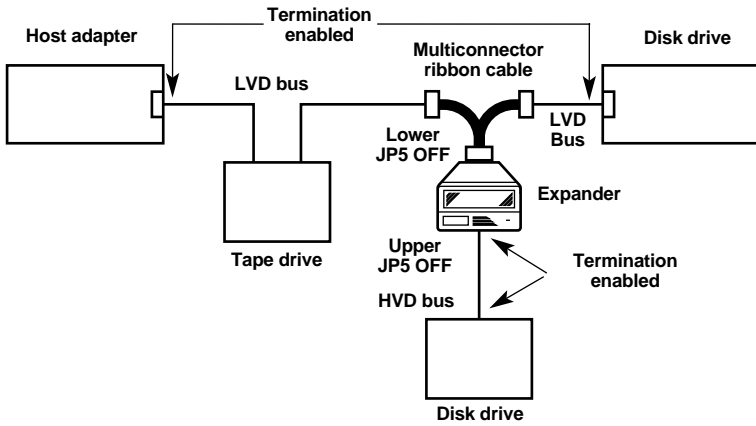

Figure 3-2. One segment passes through the Expander, while the other ends and is terminated.

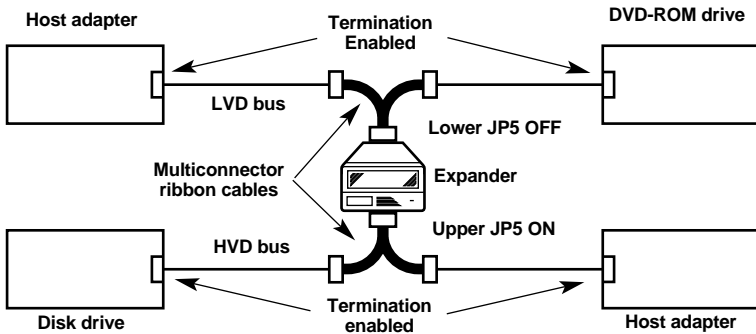

Figure 3-3. Both segments pass unterminated through the Expander.

- **Termination at the Other End(s) of the Segment (JP1 and JP4):** The JP1 and JP4 jumper posts control whether or not the Expander provides TERMPWR output to support remote termination.

To explain: Most of the current generation of SCSI host adapters, disk drives, and other devices have built-in internal terminators, like those in the Expander, that can be used to terminate the SCSI bus if that device happens to be the first or last device attached to the bus. The remote ends of the SCSI-bus segments that you'll be attaching to the Expander will probably be able to be terminated this way.

But if, on a SCSI segment that will be attached to the Expander, the first or last device (or both) don't have an internal terminator, you will need to attach an external terminator to that device instead. That external terminator will need to draw its power from a "terminator power" (TERMPWR) voltage that must be present on the SCSI bus. Most SCSI devices can be set to provide TERMPWR.

NOTE

It's easy to make mistakes when installing external SCSI termination. If you'll need to do so, please call Black Box Technical Support to discuss your application.

If the remote termination for the segments that will be attached to the Expander can be handled with another device's internal terminator, or with an external terminator that gets its TERMPWR from some other device(s), you can leave jumper posts JP1 and JP4 in their factory-default setting (no jumpers installed). But if you'll need to use an external terminator *that gets its TERMPWR from the Expander* for remote termination on a segment attached to either of the Expander's ports, install a jumper on the posts for that port. Install a jumper on JP1 to have the Expander provide TERMPWR on its HVD port. Install a jumper on JP4 to have the Expander provide TERMPWR on its LVD/SE port.

Refer to Figure 3-1 on the previous page. In that illustration, the host adapter and disk drive both have enabled internal terminators. But if the host adapter didn't have an internal terminator and couldn't provide TERMPWR, you would have to install a jumper on the Expander's JP4 posts. If the same were true of the disk drive, you would have to install a jumper on the Expander's JP1 posts.

4. Installation and Operation

4.1 Connecting SCSI-Bus Cables

To attach the Ultra2 SCSI LVD/HVD Multimode Expander to one end of a SCSI-bus segment, run SCSI cable from the desired port on the Expander to another SCSI device: from the HVD port to an HVD device, from the LVD/SE port to an LVD or SE device.

CAUTION!

Be careful *not* to connect HVD devices to the Expander's LVD/SE port. This could damage or destroy the Expander.

To tap the Expander into the middle of a segment, first turn OFF the Expander's internal termination for the port where you will make this connection—see **Section 3.2**. Then get a (short!) "T"-style SCSI cable or adapter with three or more connectors and plug one of its central connectors into that port. Finally, run regular SCSI cables from the end connectors of the "T" cable/adapter to the previous device and next device in the segment.

CAUTION!

The T adapter or cable must be wired so that it does not contain a "stub" (does not branch)—stubbing/branching will cause your SCSI bus to fail. Instead, the cable or adapter should be constructed so that all of the wires run from one connector to the next, to the next, and so on, in sequence. For LVD "T" connections, we suggest our 7-connector LVD ribbon cable (product code EVMSCC22). For HVD or single-ended "T" connections, we suggest our 5-connector Ultra SCSI ribbon cable (product code EVMSCC16).

Keep in mind that the maximum cable lengths allowed on any SCSI bus are fairly strict, though they vary by the type of bus and by the cable size and insulation. Table 4-1 lists the maximum recommended cable lengths for each type of SCSI interface that the Expander supports.

Table 4-1. Maximum Cable Lengths

Interface	Maximum Distance
HVD (any generation)	25 m (82 ft.)
SCSI-1 SE	6 m (20 ft.)
Fast/Wide (SCSI-2) SE	3 m (10 ft.)
Ultra Wide (SCSI-3) SE	<i>Fewer than 5 devices: 3 m (10 ft.); 5 or more devices: 1.5 m (5 ft.)</i>
Ultra2 Wide LVD	<i>Multiple devices: 12 m (40 ft.); Two devices point to point: 25 m (82 ft.)</i>

4.2 Connecting AC Power and Observing External LEDs

Run the included power cord from the IEC 320 male inlet on the rear of the Expander to a working AC outlet. Once you've plugged in the unit, flip the rocker switch on the rear of the unit to turn the Expander ON. The green external Power LED on its front panel should light immediately. The Expander should now be ready for continuous operation.

The Expander's Power LED is easy to spot, even when it's dark; there is a special cutout for it in the upper right-hand corner of the front panel. The amber Busy LED isn't so easy to see when it's not lit; it's embedded in the venting in the front panel's lower right-hand corner. However, the Busy LED will begin flashing as soon as data begins flowing on either attached SCSI-bus segment. During exceptionally heavy traffic conditions, the flashing might become so persistent that the LED briefly appears to be steadily lit.

5. Applications

5.1 Applications That Will Work

Here are several ways in which Ultra2 SCSI LVD/HVD Multimode Expanders can be used in a SCSI-bus system, helping LVD and single-ended SCSI-bus segments to work as one logical SCSI bus. (As always, each bus segment must be terminated at both ends.)

Figure 5-1 shows how to use an Expander to allow an HVD adapter to reach LVD devices.

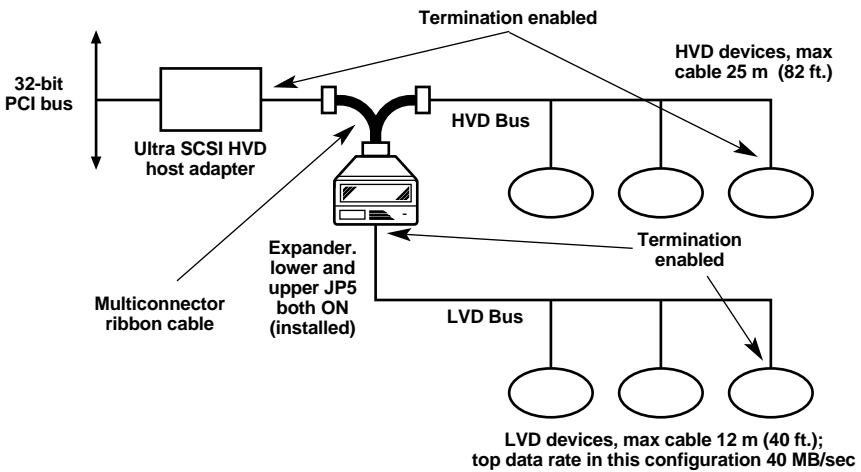

Figure 5-1. Extending an HVD bus.

Figure 5-2 shows how LVD and HVD devices can be mixed with no speed degradation for the LVD devices.

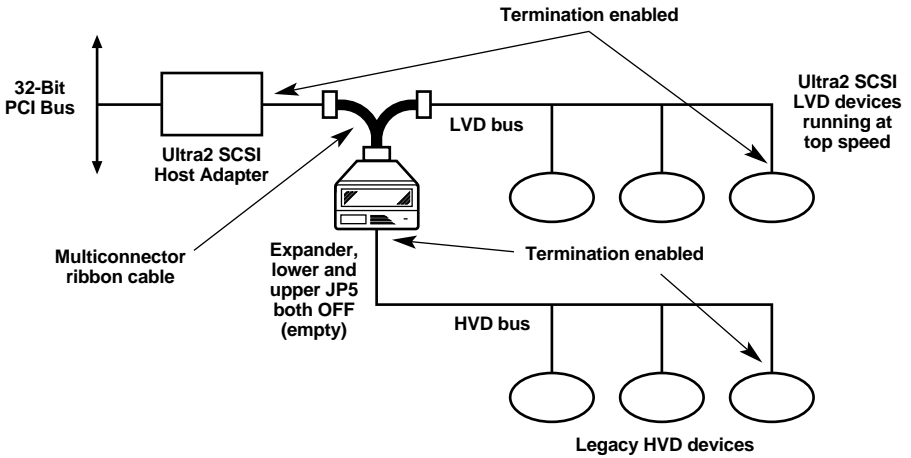

Figure 5-2. Adding legacy devices to an Ultra2 SCSI LVD bus.

Figure 5-3 shows how to use a pair of Expanders to insert maximum LVD point-to-point cable length into an HVD SCSI bus. (Normal configuration rules for HVD segments still apply to the segments at either end of this Extender-to-Extender link.)

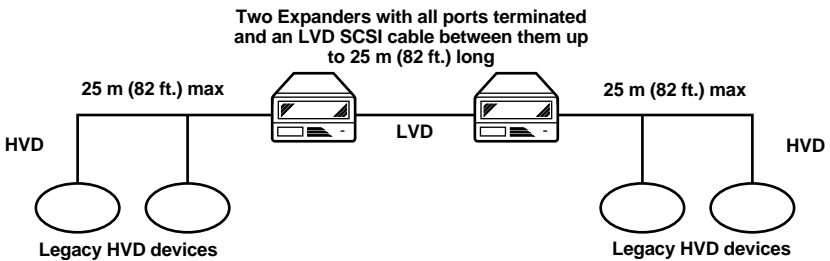

Figure 5-2. Adding maximum LVD point-to-point cabling.

5.2 Applications That Won't Work

Here are two ways that you must *avoid* trying to use the Expanders.

Applications like that shown in Figure 5-4 won't work, because devices on the left must send data through more than two Expanders to reach the devices on the right. Two is the maximum number of Expanders through which SCSI data can pass.

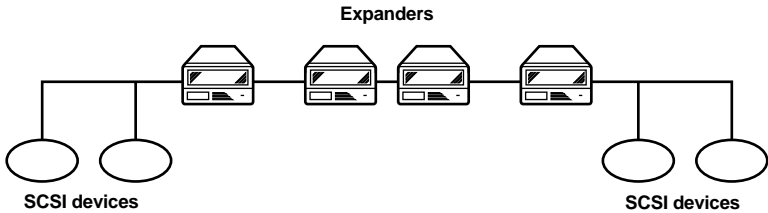

Figure 5-4. An application with too many Expanders.

Applications like that shown in Figure 5-5 won't work either, because you can't have two LVD segments connected by an HVD segment. The two LVD devices would attempt to communicate at 40 MHz, a transfer rate not supported by the HVD segment, and the system would fail.

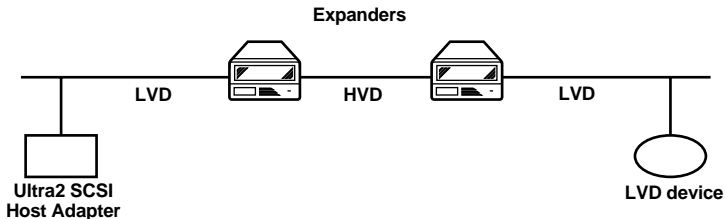

Figure 5-5. An application with an HVD segment between two LVD segments.

6. Troubleshooting

6.1 Calling Black Box

If you determine that your Ultra2 SCSI LVD/HVD Multimode Expander is malfunctioning, *do not attempt to alter or repair the unit*. It contains no user-serviceable parts. Contact Black Box Technical Support at 724-746-5500.

Before you do, make a record of the history of the problem. We will be able to provide more efficient and accurate assistance if you have a complete description, including:

- the nature and duration of the problem;
- when the problem occurs;
- the components involved in the problem—that is, what type of cable, SCSI host adapter, SCSI devices, etc.;
- any particular application that, when used, appears to create the problem or make it worse; and
- the results of any testing you've already done.

6.2 Shipping and Packaging

If you need to transport or ship your Expander:

- Package it carefully. We recommend that you use the original container.
- Before you ship the unit back to Black Box for repair or return, contact us to get a Return Authorization (RA) number.

Appendix A: Port Pinouts

The tables in this appendix show the possible pinouts of the Ultra2 SCSI LVD/HVD Multimode Expander's ports. The Expander's HVD port will always have the pinout listed in **Section A.1**. If the Expander detects that its LVD/SE port is attached to an LVD bus, it will use the LVD pinout listed in **Section A.2** for that port. If the Expander detects that the LVD/SE port is attached to a single-ended bus, it will use the SE pinout listed in **Section A.3**. Each of these tables also lists the wire (conductor) number that carries the signals when you use flat-ribbon cable.

A.1 High-Voltage Differential (HVD) Pinout

Signal Name	Pin No.	Wire No. in Cable	Wire No. in Cable	Pin No.	Signal Name
+DB(12)	1	1	2	35	-DB(12)
+DB(13)	2	3	4	36	-DB(13)
+DB(14)	3	5	6	37	-DB(14)
+DB(15)	4	7	8	38	-DB(15)
+DB(P1)	5	9	10	39	-DB(P1)
GROUND	6	11	12	40	GROUND
+DB(0)	7	13	14	41	-DB(0)
+DB(1)	8	15	16	42	-DB(1)
+DB(2)	9	17	18	43	-DB(2)
+DB(3)	10	19	20	44	-DB(3)
+DB(4)	11	21	22	45	-DB(4)
+DB(5)	12	23	24	46	-DB(5)
+DB(6)	13	25	26	47	-DB(6)
+DB(7)	14	27	28	48	-DB(7)
+DB(P)	15	29	30	49	-DB(P)
DIFFSENS	16	31	32	50	GROUND
TERMPWR	17	33	34	51	TERMPWR
TERMPWR	18	35	36	52	TERMPWR
RESERVED	19	37	38	53	RESERVED
+ATN	20	39	40	54	-ATN
GROUND	21	41	42	55	GROUND

Signal Name	Pin No.	Wire No. in Cable	Wire No. in Cable	Pin No.	Signal Name
+BSY	22	43	44	56	-BSY
+ACK	23	45	46	57	-ACK
+RST	24	47	48	58	-RST
+MSG	25	49	50	59	-MSG
+SEL	26	51	52	60	-SEL
+C/D	27	53	54	61	-C/D
+REQ	28	55	56	623	-REQ
+I/O	29	57	58	63	-I/O
GROUND	30	59	60	64	GROUND
+DB(8)	31	61	62	65	-DB(8)
+DB(9)	32	63	64	66	-DB(9)
+DB(10)	33	65	66	67	-DB(10)
+DB(11)	34	67	68	68	-DB(11)

A.2 Low-Voltage Differential (LVD) Pinout

Signal Name	Pin No.	Wire No. in Cable	Wire No. in Cable	Pin No.	Signal Name
+DB(12)	1	1	2	35	-DB(12)
+DB(13)	2	3	4	36	-DB(13)
+DB(14)	3	5	6	37	-DB(14)
+DB(15)	4	7	8	38	-DB(15)
+DB(P1)	5	9	10	39	-DB(P1)
+DB(0)	6	11	12	40	-DB(0)
+DB(1)	7	13	14	41	-DB(1)
+DB(2)	8	15	16	42	-DB(2)
+DB(3)	9	17	18	43	-DB(3)
+DB(4)	10	19	20	44	-DB(4)
+DB(5)	11	21	22	45	-DB(5)
+DB(6)	12	23	24	46	-DB(6)
+DB(7)	13	25	26	47	-DB(7)
+DB(P)	14	27	28	48	-DB(P)
GROUND	15	29	30	49	GROUND
DIFFSENS	16	31	32	50	GROUND
TERMPWR	17	33	34	51	TERMPWR
TERMPWR	18	35	36	52	TERMPWR
RESERVED	19	37	38	53	RESERVED
GROUND	20	39	40	54	GROUND
+ATN	21	41	42	55	-ATN
GROUND	22	43	44	56	GROUND
+BSY	23	45	46	57	-BSY
+ACK	24	47	48	58	-ACK
+RST	25	49	50	59	-RST
+MSG	26	51	52	60	-MSG
+SEL	27	53	54	61	-SEL
+C/D	28	55	56	62	-C/D
+REQ	29	57	58	63	-REQ
+I/O	30	59	60	64	-I/O

Signal Name	Pin No.	Wire No. in Cable	Wire No. in Cable	Pin No.	Signal Name
+DB(8)	31	61	62	65	-DB(8)
+DB(9)	32	63	64	66	-DB(9)
+DB(10)	33	65	66	67	-DB(10)
+DB(11)	34	67	68	68	-DB(11)

A.3 Single-Ended (SE) Pinout

Single-ended signals whose names are preceded by “-” are active low.

Signal Name	Pin No.	Wire No. in Cable	Wire No. in Cable	Pin No.	Signal Name
RETURN	1	1	2	35	-DB(12)
RETURN	2	3	4	36	-DB(13)
RETURN	3	5	6	37	-DB(14)
RETURN	4	7	8	38	-DB(15)
RETURN	5	9	10	39	-DB(P1)
RETURN	6	11	12	40	-DB(0)
RETURN	7	13	14	41	-DB(1)
RETURN	8	15	16	42	-DB(2)
RETURN	9	17	18	43	-DB(3)
RETURN	10	19	20	44	-DB(4)
RETURN	11	21	22	45	-DB(5)
RETURN	12	23	24	46	-DB(6)
RETURN	13	25	26	47	-DB(7)
RETURN	14	27	28	48	-DB(P)
GROUND	15	29	30	49	GROUND
GROUND	16	31	32	50	GROUND
TERMPWR	17	33	34	51	TERMPWR
TERMPWR	18	35	36	52	TERMPWR
RESERVED	19	37	38	53	RESERVED
GROUND	20	39	40	54	GROUND
RETURN	21	41	42	55	-ATN
GROUND	22	43	44	56	GROUND
RETURN	23	45	46	57	-BSY
RETURN	24	47	48	58	-ACK
RETURN	25	49	50	59	-RST
RETURN	26	51	52	60	-MSG
RETURN	27	53	54	61	-SEL
RETURN	28	55	56	62	-C/D

Signal Name	Pin No.	Wire No. in Cable	Wire No. in Cable	Pin No.	Signal Name
RETURN	29	57	58	63	-REQ
RETURN	30	59	60	64	-I/O
RETURN	31	61	62	65	-DB(8)
RETURN	32	63	64	66	-DB(9)
RETURN	33	65	66	67	-DB(10)
RETURN	34	67	68	68	-DB(11)

Appendix B: Block Diagram

Figure B-1 on the next page is a basic block diagram of the Expander. The receiver/transmitter pairs move the data from one bus to the other through the internal logic of the Expander, which takes care of cleaning up the signals as well as translating any differences between the buses.

The Expander contains logic to control the signal flow between the two SCSI ports. It also has filtering and delay circuits to remove false edges from the REQ and ACK signals. This logic enables the bus segments to be in the same SCSI bus state after a short delay.

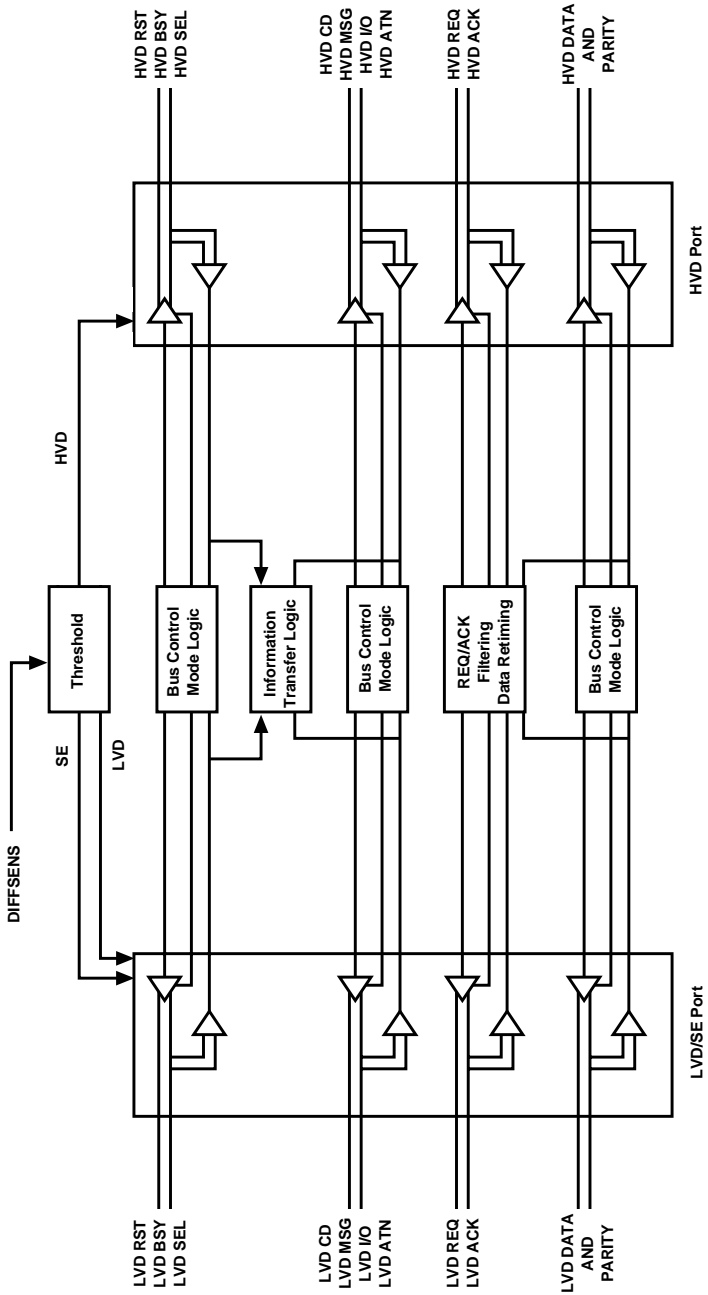

Figure B-1. Block diagram.

DISCLAIMERS

Information in this manual is subject to change without notice.

The manufacturer and its agents assume no responsibility for errors appearing in, or information omitted from, this manual.

NOTES

NOTES