



©Copyright 1993. Black Box Corporation. All rights reserved.

1000 Park Drive • Lawrence, PA 15055-1018 • 724-746-5500 • Fax 724-746-0746



RS-232 ↔ RS-485 Interface Converter

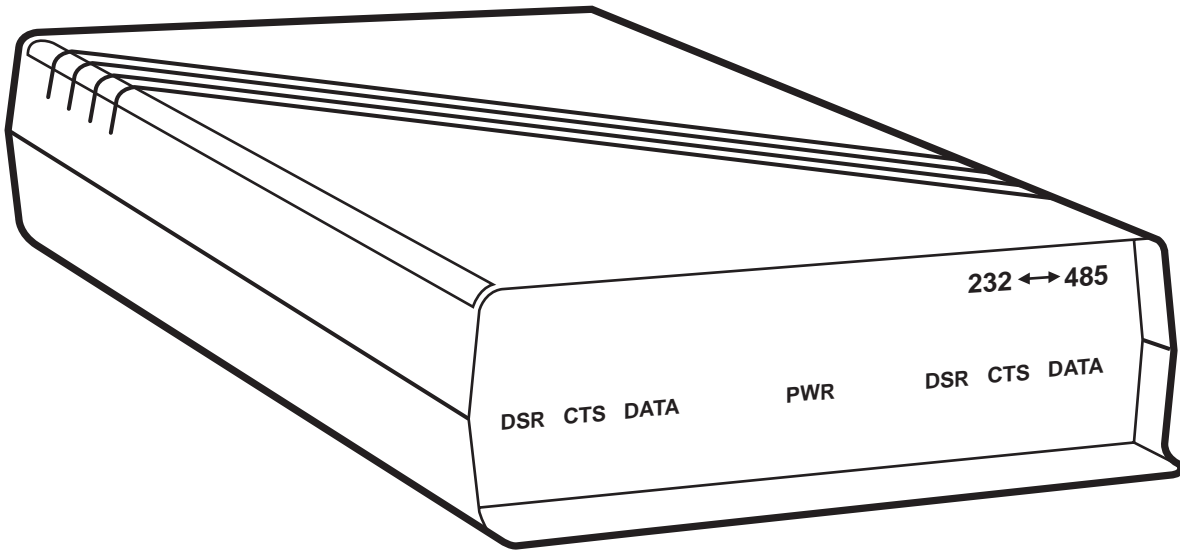

**CUSTOMER
SUPPORT
INFORMATION**

Order **toll-free** in the U.S. 24 hours, 7 A.M. Monday to midnight Friday: **877-877-BBOX**
FREE technical support, 24 hours a day, 7 days a week: Call **724-746-5500** or fax **724-746-0746**
Mail order: **Black Box Corporation**, 1000 Park Drive, Lawrence, PA 15055-1018
Web site: www.blackbox.com • E-mail: info@blackbox.com

**FEDERAL COMMUNICATIONS COMMISSION
RADIO FREQUENCY INTERFERENCE STATEMENT**

This equipment generates, uses, and can radiate radio frequency energy and if not installed and used properly, that is, in strict accordance with the manufacturer's instructions, may cause interference to radio communication. It has been tested and found to comply with the limits for a Class A computing device in accordance with the specifications in Subpart J of Part 15 of FCC Rules, which are designed to provide reasonable protection against such interference when the equipment is operated in a commercial environment. Operation of this equipment in a residential area is likely to cause interference, in which case the user at his own expense will be required to take whatever measures may be required to correct the interference.

Changes or modifications not expressly approved by the party responsible for compliance could void the user's authority to operate the equipment.

"This digital apparatus does not exceed the Class A limits for Radio noise emission from digital apparatus set out in the Radio Interference Regulation of the Canadian Department of Communications."

"Le présent appareil numérique n'émet pas de bruits radioélectriques dépassant les limites applicables aux appareils numériques de la classe A prescrites dans le Règlement sur le brouillage radioélectrique édicté par le ministère des Communications du Canada."

TRADEMARKS

IBM® is a registered trademark of International Business Machines.

Contents

1.0 SPECIFICATIONS.....4

2.0 INTRODUCTION.....5

3.0 INSTALLATION.....7

 3.1 Jumpers and DIP Switches.....7

 3.2 Select DTE/DCE Operation7

 3.3 Physical Installation7

 3.4 Indicators.....11

 3.5 Interface Pinouts14

1.0 Specifications

Speed —	Approximately 40,000 bps
Indicators —	7 high-efficiency LEDs show the status of RS-232/RS-485 incoming signals and indicate the power ON/OFF condition. RS-232 Port: DSR, CTS, DATA RS-485 Port: DSR, CTS, DATA
Controls —	RS-232 port: DTE/DCE jumper-selectable RS-485 port: DTE/DCE jumper-selectable
Connectors —	RS-232 port: 25-pin sub-D female RS-485 port: 37-pin sub-D female
Environmental —	Maximum Storage Temperature: 158°F (70°C) Maximum Operating Temperature 122°F (50°C)
Power —	115 VAC power supply: ±10%, 100 mA rms 230 VAC power supply: ±10%, 50 mA rms
Size —	IC485A-R2: 2.3"H x 8"W x 11.9"D (5.8 x 20.3 x 30.2 cm) IC485C-R2: 1.2"H x 7.5"W x 11.4"L (3 x 19 x 28.9 cm)
Weight —	1.8 lb. (0.8 kg)

2.0 Introduction

The RS-232 ↔ RS-485 Interface Converter provides bi-directional synchronous or asynchronous conversion for all commonly used RS-232 and RS-485 signals. The unit is designed with one port configured as Data Terminal Equipment (DTE) and the other as Data Communications Equipment (DCE). Operation is not recommended with both ports configured either DCE or DTE when operating in synchronous mode.

The unit has two jumper-selectable configurations: one for connecting RS-485 modem equipment to RS-232 terminal equipment (DTE to DCE), and one for connecting RS-232 modem equipment to RS-485 terminal equipment (DCE to DTE). Both configurations allow bi-directional data transfer.

A two-wire half-duplex application is shown in Figure 2-1, followed by a four-wire full-duplex application diagram in Figure 2-2. An RS-232 cable configuration for an IBM® PC is shown in Figure 2-3.

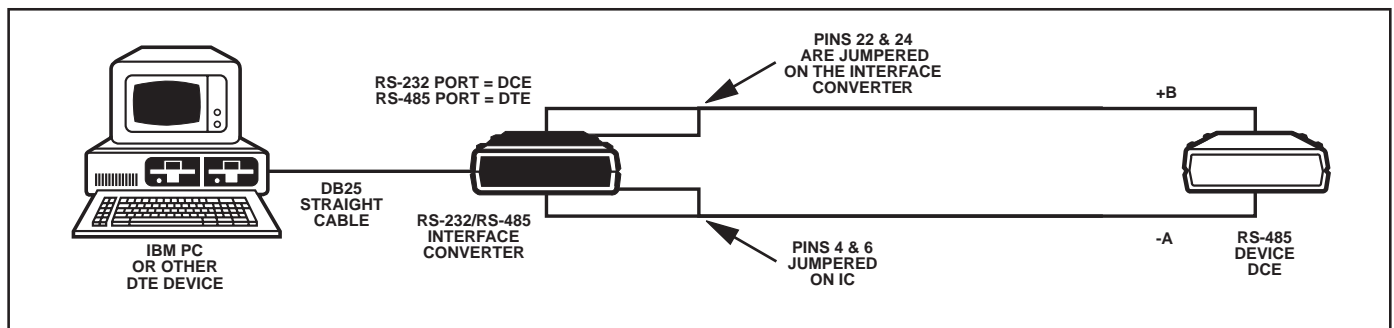

Figure 2-1. 2-Wire Asynchronous Application

NOTE

The two- and four-wire application diagrams illustrate only the wiring of the data leads. All other leads are still passed through from one port to the other.

NOTE

Echo is not disabled in 2-wire half-duplex operation. A carrier signal or transmitter being enabled on the RS-485 line will not raise the RTS or CD signals on the RS-232 port.

NOTE

In a two-wire application, the toggling of the RTS lead from the RS-232 port enables and disables the RS-485 transmitter. Because hardware handshaking (RTS) is required by the RS-232 standard in order to control the RS-485 drivers, and RTS is not supported by most communications packages despite the fact that it is software-dependent, you may need a customized software package in order to implement any 2-wire application.

RS-232 ↔ RS-485 INTERFACE CONVERTER

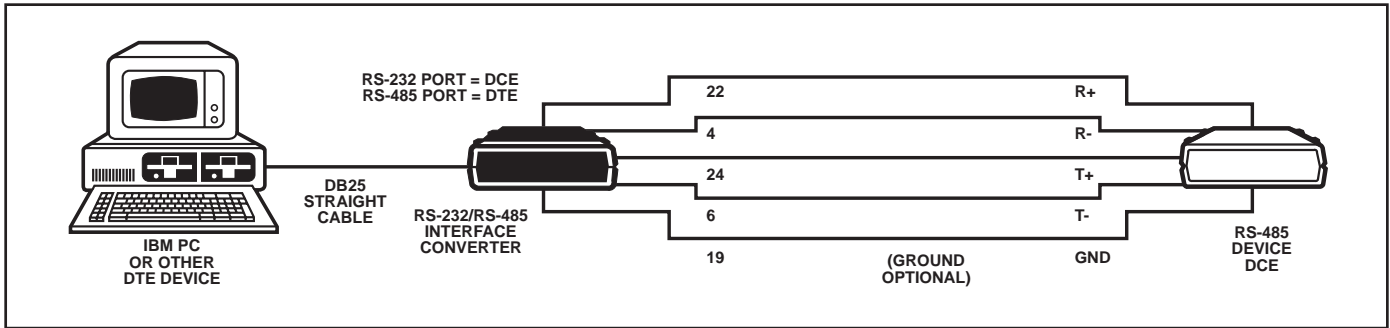

Figure 2-2. 4-Wire Asynchronous Application.

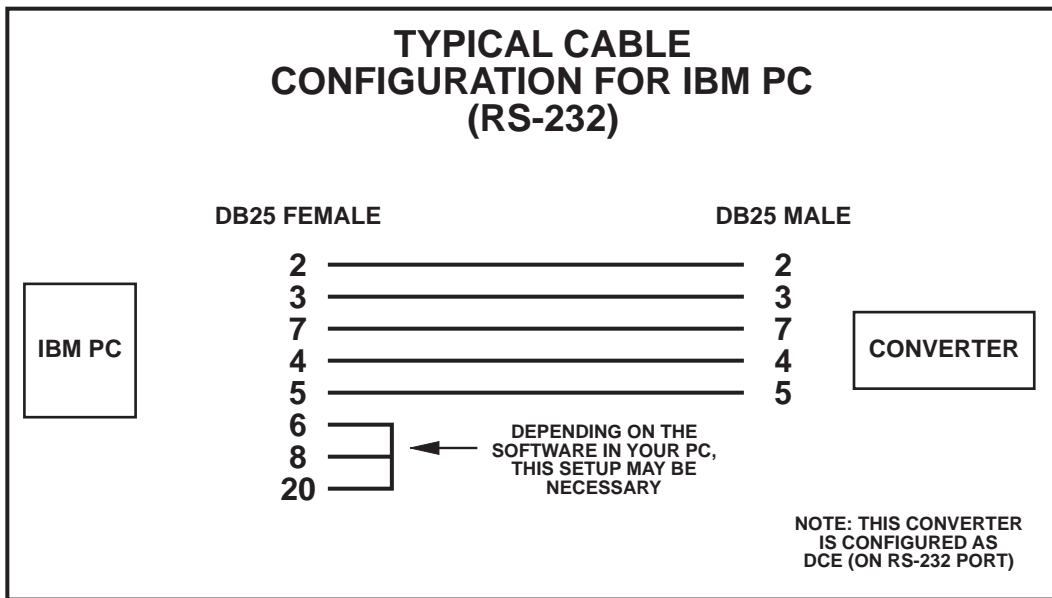

Figure2-3. Cable Configuration for the IBM PC.

There are three models of this interface converter:

- **IC485A-R2** — an RS-232 ↔ RS-485 interface converter standalone unit for 115 VAC operation.
- **IC485AE-R2** — a standalone unit for 220 VAC operation.
- **IC485C-R2** — a rackmounted printed-circuit card.

The same Card is used for both 115 volts and 230 volts.

An Interface Converter Rack is also available. This is a 19" rack capable of holding up to eight printed circuit cards. It operates in either 115-VAC or 230-VAC applications. The rack (RM060) has its own power supply, which is switchable between 115- and 230-VAC operation.

3.0 Installation

Follow the instructions in Sections 3.1 and 3.2 before installing the Converter.

3.1 Jumpers and Switches

The Interface Converter has eleven jumpers (listed in Table 3-3) and one 8-position DIP switch labeled S1. Switch S1 functions to provide termination on the converter's RS-485 ports. (Refer to Figure 3-1 for the position of Switch S1 on the printed-circuit board.) When the switch is in the ON position, a 120-ohm resistor is installed across the RS-485 pin carrying the particular signal indicated in Table 3-1. Only two RS-485 devices on a network (usually the first and last device connected on the bus) will have one of the DIP switch's pins in the ON position. The rest of

the converters will have these pins set to OFF. Set this DIP switch's pins to the configuration that your device requires. See Table 3-1.

3.2 Select DTE/DCE Operation

The RS-232 ↔ RS-485 Interface Converter has two jumper-selectable configurations for selecting DTE/DCE operation on each port. One is for connecting RS-485 Data Communications Equipment (DCE) to RS-232 Data Terminal Equipment (DTE). The second configuration is for connecting RS-232 DCE to RS-485 DTE. These settings are determined by DIP shunt settings located inside the unit on the printed circuit board. To set the interfaces, refer to Figure 3-1 for their location and then set the DIP shunts according to Table 3-2.

Table 3-1. Switch S1.

DIP Switch Pin	Signal Terminated by the Resistor
1	Data
2	Receive Timing
3	Send Timing
4	Terminal Timing
5	Data Mode
6	Terminal Ready
7	RTS/CTS
8	Receiver Ready

NOTE

Operating the converter with both ports configured for either DCE or DTE operation is not recommended and can damage the converter.

3.3 Physical Installation

After you configure the Converter, follow these steps to install it in your application.

1. Attach the cable from the RS-485 device to the 37-pin female receptacle on the rear panel of the interface converter case.
2. Attach the cable from the RS-232 device to the 25-pin female receptacle on the rear panel of the interface converter case.
3. Plug the 4-pin power cord into the receptacle on the rear panel of the case and plug the power module into an AC outlet.

RS-232 ↔ RS-485 INTERFACE CONVERTER

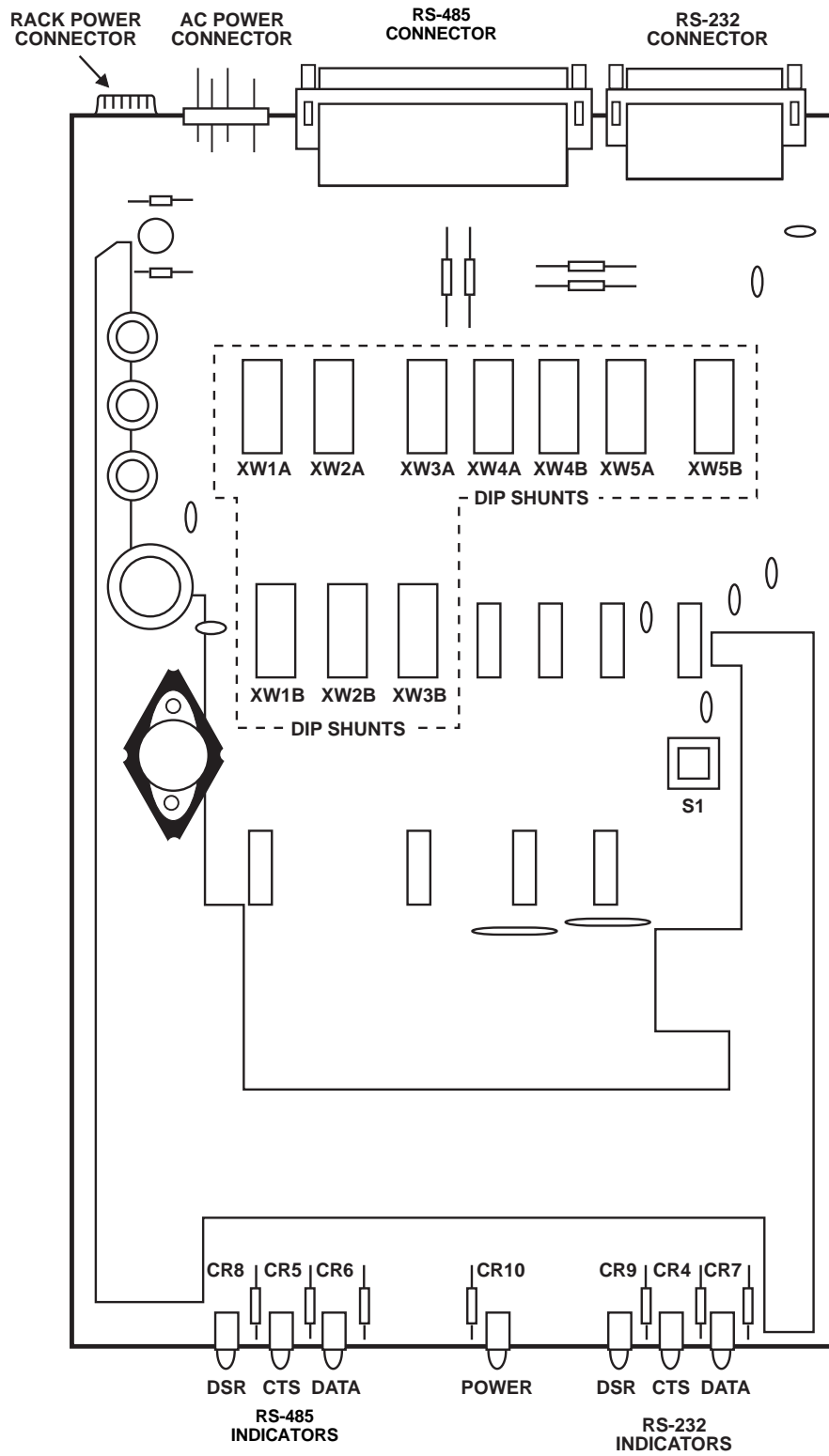

Figure 3-1. Component Layout.

Table 3-2. DTE/DCE DIP Shunts Settings.

RS-485 PORT		RS-232 PORT	
To appear as	Put a shunt in	To appear as	Put a shunt in
DTE	XW1A XW2A XW3A	DTE	XW4A XW5A
DCE	XW1B XW2B XW3B	DCE	XW4B XW5B

RS-232 ↔ RS-485 INTERFACE CONVERTER

Table 3-3 contains definitions of all the jumpers on the interface converter's printed-circuit board.

Table 3-3. Jumpers.

Jumper	Function
W1, W2, W3	These 16-pin DIP shunts are used to select DTE/DCE for the RS-485 port. Install each in the DTE or DCE position as desired.
W4, W5	These 16-pin DIP shunts are used to select DTE/DCE for the RS-232 port. Install each in the DTE or DCE position as desired.
W6	Selects RTS/CTS loopback delay for the RS-485 port when W9 is in the B-C position (RTS-CTS loopback) as follows: A=0 msec B=10 msec C=50 msec
W7	Selects RTS/CTS loopback delay for the RS-232 port when W10 is in the A-B position (RTS-CTS loopback) as follows: A=0 msec B=10 msec C=50 msec
W8	Position B-C: RS-485 transmitters are always enabled. This position should be selected for four-wire applications. Position A-B: tri-state control line of the RS-485 transmitters is driven by the RS-232 equipment's RTS/CTS circuit.
NOTE: When W8 is in the B-C position, it overrides W9 and W10.	
W9	Select RTS/CTS signal source for the RS-485 port as follows: Position A-B: RS-485 RTS/CTS signal is driven by the RS-232 CTS signal. Position B-C: RS-485 RTS/CTS signal is driven by the RTS/CTS loopback/delay circuit.
W10	Selects RTS/CTS signal source for the RS-232 port as follows: Position A-B: RS-232 RTS/CTS signal is driven by the RTS/CTS loopback/delay circuit. Position B-C: RS-232 RTS/CTS signal is driven by the RS-485 CTS signal.
W11	Connects the DC power supply common to AC power ground. This is a soldered jumper which is left open as a factory default. If you wish, you can hardwire it to provide both signal and frame ground.

3.4 Indicators

The interface converter is equipped with seven LED indicators located on the front panel, that indicate input signals, NOT output.

- Three indicators reflect conditions on the RS-232 interface: DSR (Data Set Ready), CTS (Clear To Send), and Data.
- Three indicators reflect conditions on the RS-485 interface: DSR (Data Set ready), CTS (Clear To Send), and Data.
- One indicator, located in the center of the front panel, PWR (Power), indicates when power is applied to the unit.

Figures 3-2 and 3-3 illustrate signal flow in DTE and DCE configurations.

NOTE

Some LEDs may be lit when no input signal is present. This is not a malfunction but a floating state condition at the input which causes the output of that driver to indicate a positive voltage condition.

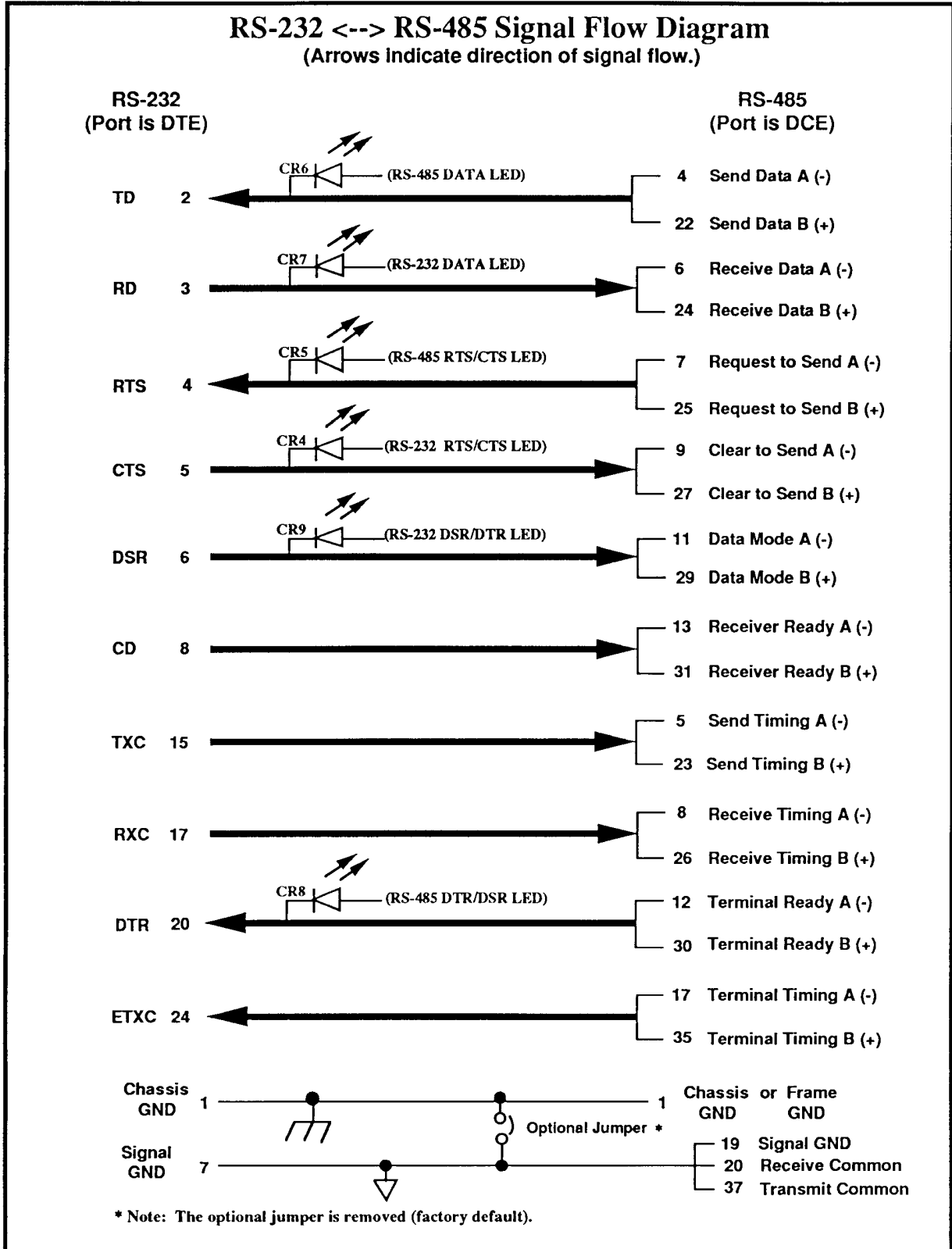

Figure 3-2. Signal Flow Diagram A.

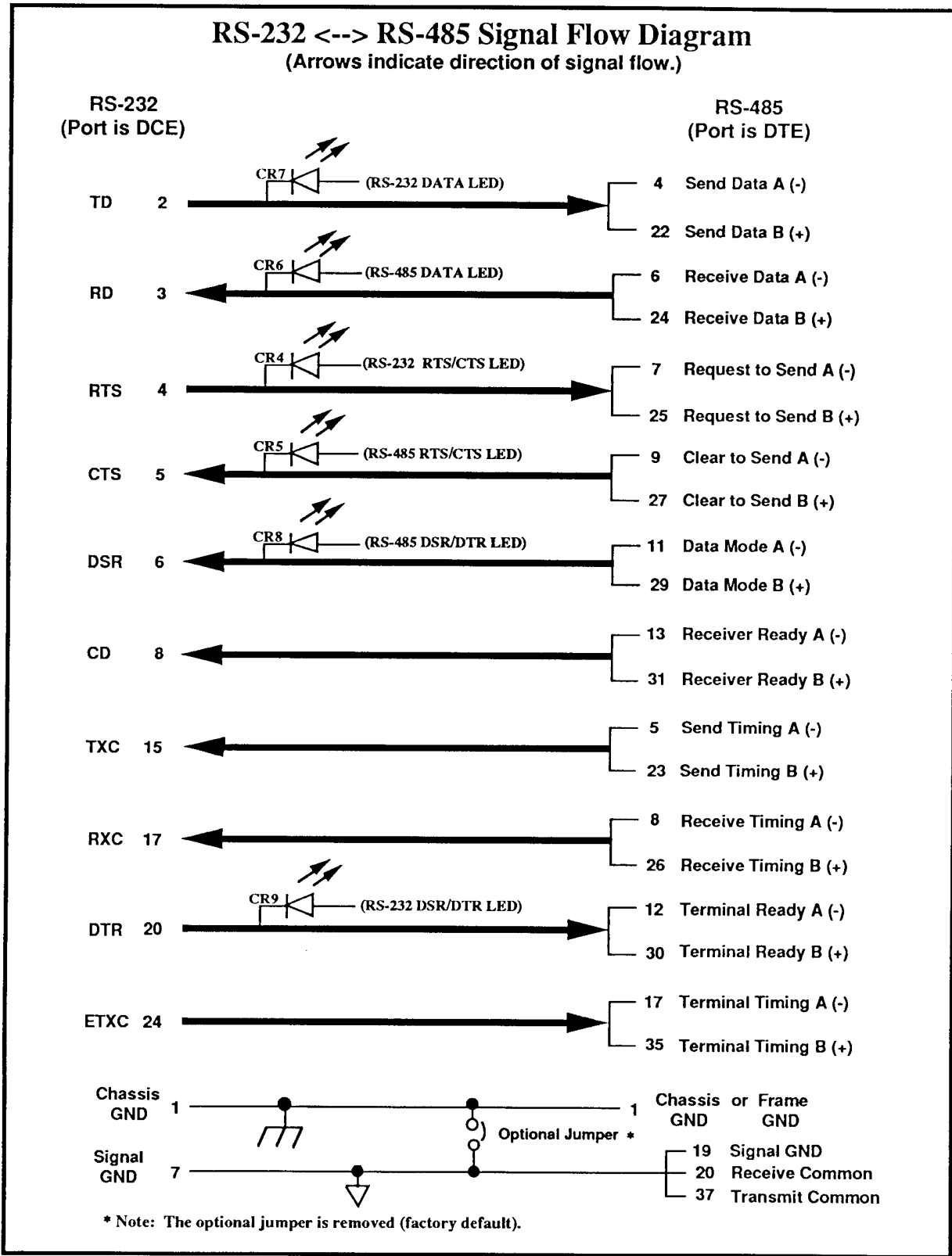

Figure 3-3. Signal Flow Diagram B.

3.5 Interface Pinouts

Figures 3-4 and 3-5 show pinouts for the RS-232 and RS-485 interfaces.

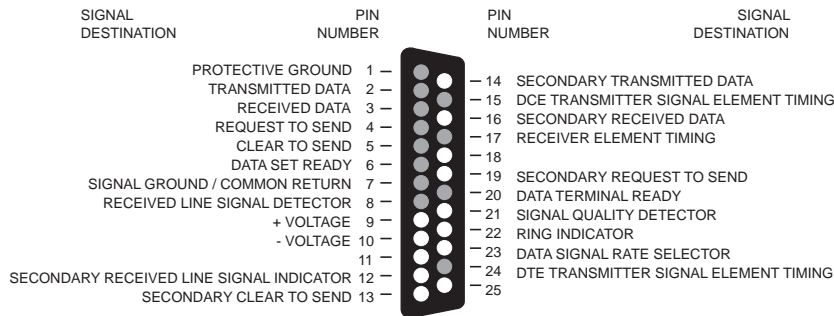

Figure 3-4. RS-232C Interface.

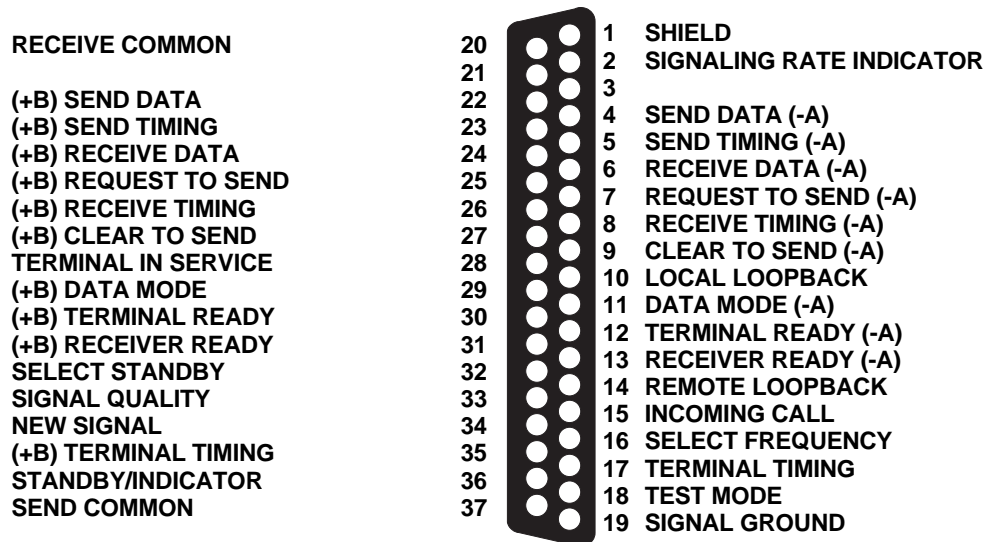

Figure 3-5. RS-485 Interface.