

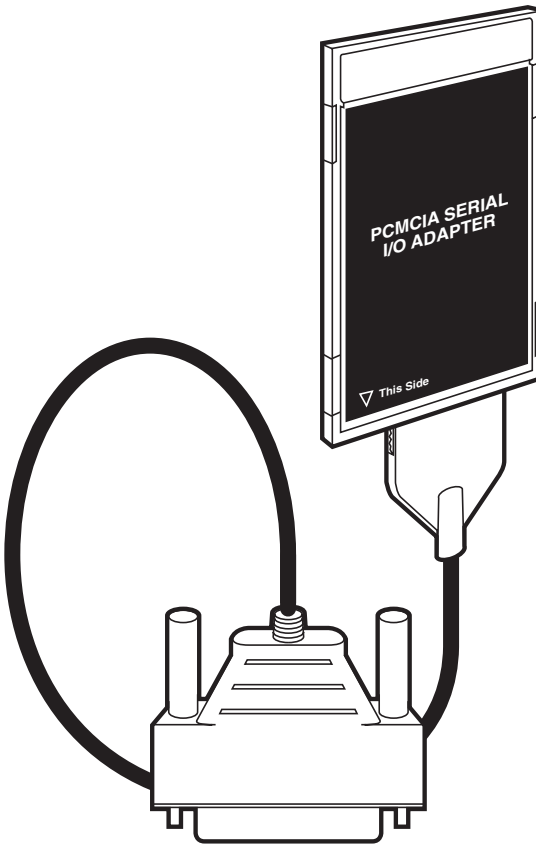

## PCMCIA Serial I/O Adapter



**CUSTOMER  
SUPPORT  
INFORMATION**

Order toll-free in the U.S.: Call **877-877-BBOX** (outside U.S. call **724-746-5500**)  
FREE technical support 24 hours a day, 7 days a week: Call **724-746-5500** or fax **724-746-0746**  
Mailing address: **Black Box Corporation**, 1000 Park Drive, Lawrence, PA 15055-1018  
Web site: [www.blackbox.com](http://www.blackbox.com) • E-mail: [info@blackbox.com](mailto:info@blackbox.com)

**FEDERAL COMMUNICATIONS COMMISSION  
AND  
INDUSTRY CANADA  
RADIO FREQUENCY INTERFERENCE STATEMENTS**

This equipment generates, uses, and can radiate radio frequency energy and if not installed and used properly, that is, in strict accordance with the manufacturer's instructions, may cause interference to radio communication. It has been tested and found to comply with the limits for a Class A computing device in accordance with the specifications in Subpart J of Part 15 of FCC rules, which are designed to provide reasonable protection against such interference when the equipment is operated in a commercial environment. Operation of this equipment in a residential area is likely to cause interference, in which case the user at his own expense will be required to take whatever measures may be necessary to correct the interference.

Changes or modifications not expressly approved by the party responsible for compliance could void the user's authority to operate the equipment.

*This digital apparatus does not exceed the Class A limits for radio noise emission from digital apparatus set out in the Radio Interference Regulation of Industry Canada.*

*Le présent appareil numérique n'émet pas de bruits radioélectriques dépassant les limites applicables aux appareils numériques de la classe A prescrites dans le Règlement sur le brouillage radioélectrique publié par Industrie Canada.*

**NORMAS OFICIALES MEXICANAS (NOM)  
ELECTRICAL SAFETY STATEMENT**

**INSTRUCCIONES DE SEGURIDAD**

1. Todas las instrucciones de seguridad y operación deberán ser leídas antes de que el aparato eléctrico sea operado.
2. Las instrucciones de seguridad y operación deberán ser guardadas para referencia futura.
3. Todas las advertencias en el aparato eléctrico y en sus instrucciones de operación deben ser respetadas.
4. Todas las instrucciones de operación y uso deben ser seguidas.
5. El aparato eléctrico no deberá ser usado cerca del agua—por ejemplo, cerca de la tina de baño, lavabo, sótano mojado o cerca de una alberca, etc..
6. El aparato eléctrico debe ser usado únicamente con carritos o pedestales que sean recomendados por el fabricante.
7. El aparato eléctrico debe ser montado a la pared o al techo sólo como sea recomendado por el fabricante.
8. Servicio—El usuario no debe intentar dar servicio al equipo eléctrico más allá a lo descrito en las instrucciones de operación. Todo otro servicio deberá ser referido a personal de servicio calificado.
9. El aparato eléctrico debe ser situado de tal manera que su posición no interfiera su uso. La colocación del aparato eléctrico sobre una cama, sofá, alfombra o superficie similar puede bloquea la ventilación, no se debe colocar en libreros o gabinetes que impidan el flujo de aire por los orificios de ventilación.
10. El equipo eléctrico deber ser situado fuera del alcance de fuentes de calor como radiadores, registros de calor, estufas u otros aparatos (incluyendo amplificadores) que producen calor.
11. El aparato eléctrico deberá ser conectado a una fuente de poder sólo del tipo descrito en el instructivo de operación, o como se indique en el aparato.

12. Precaución debe ser tomada de tal manera que la tierra física y la polarización del equipo no sea eliminada.
13. Los cables de la fuente de poder deben ser guiados de tal manera que no sean pisados ni pellizcados por objetos colocados sobre o contra ellos, poniendo particular atención a los contactos y receptáculos donde salen del aparato.
14. El equipo eléctrico debe ser limpiado únicamente de acuerdo a las recomendaciones del fabricante.
15. En caso de existir, una antena externa deberá ser localizada lejos de las líneas de energía.
16. El cable de corriente deberá ser desconectado del cuando el equipo no sea usado por un largo periodo de tiempo.
17. Cuidado debe ser tomado de tal manera que objetos líquidos no sean derramados sobre la cubierta u orificios de ventilación.
18. Servicio por personal calificado deberá ser provisto cuando:
  - A: El cable de poder o el contacto ha sido dañado; u
  - B: Objetos han caído o líquido ha sido derramado dentro del aparato; o
  - C: El aparato ha sido expuesto a la lluvia; o
  - D: El aparato parece no operar normalmente o muestra un cambio en su desempeño; o
  - E: El aparato ha sido tirado o su cubierta ha sido dañada.

### TRADEMARKS USED IN THIS MANUAL

AT, IBM, OS/2, and Micro Channel are registered trademarks, and PC/XT is a trademark, of IBM Corporation.

MS-DOS, Windows, and Windows NT are registered trademarks of Microsoft Corporation.

*Any other trademarks mentioned in this manual are acknowledged to be the property of the trademark owners.*

## Contents

Chapter	Page
1. Specifications.....	6
2. Introduction .....	7
2.1 Overview .....	7
2.2 The History of PCMCIA .....	7
2.3 What's Included.....	8
2.4 Features .....	8
2.5 System Requirements .....	8
2.6 Technical Description .....	9
2.6.1 Internal Baud-Rate Generator .....	9
2.6.2 Communication Standards Technical Reference.....	9
2.6.3 Cabling and Flow Control .....	12
3. Address Selection .....	14
4. Installation.....	15
4.1 Installing the Adapter in Your Operating System .....	15
4.1.1 Windows 3.1x .....	15
4.1.2 Windows 95/98/Me/2000/Windows NT.....	15
4.1.3 DOS.....	15
4.1.4 Other Operating Systems .....	15
4.2 Hardware Installation .....	15
4.3 Interface Selection.....	16
5. Troubleshooting .....	17
5.1 Problems.....	17
5.2 Calling Black Box.....	20
5.3 Shipping and Packaging.....	20
Appendix: SEAPC PC Card Client Enabler.....	21
A.1 Overview .....	21
A.2 SEAPC System Requirements .....	21
A.3 Installation.....	21
A.3.1 Executing the Driver .....	21
A.3.2 Command Line Options .....	22
A.3.3 Setup File .....	22
A.3.4 Using the PC Card on Platforms Other Than ISA.....	23

# 1. Specifications

**Interface:** IC114A-R2, IC184C-R2: RS-422 async/DB25 male;  
IC115A-R2, IC185C-R2: RS-232 async/DB25 male

**Speed:** IC114A-R2, IC115A-R2: Up to 115 kbps;  
IC184C-R2, IC185C-R2: Up to 460.8 kbps (sustained)

**Communications Chip:** IC114A-R2, IC115A-R2: 16550 UART;  
IC184C-R2, IC185C-R2: 16850 UART

**Hardware Requirements:** PC system or notebook or laptop with a Type II PCMCIA slot

**Drive Requirements:** 3.5"

**MTBF:** >150,000 hours

**Operating Temperature:** 32 to 122°F (0 to 50°C)

**Storage Temperature:** -4 to +158°F (-20 to +70°C)

**Humidity Tolerance:** 10 to 90%, noncondensing

**Power:** 5 VDC from the PC bus

**Size:** PCMCIA Type II

## 2. Introduction

### 2.1 Overview

The PCMCIA Serial I/O Adapter provides the mobile computer user with an additional high-quality communication port. The Adapter is available in four different models. The IC114A-R2 or IC184C-R2 is a PCMCIA Type II adapter providing a single asynchronous RS-422/485 port for notebook communications. The IC115A-R2 or IC185C-R2 is a PCMCIA Type II adapter providing a single asynchronous RS-232 port for notebook communications. The IC114A-R2 and IC115A-R2 models feature the 16550 UART. The IC184C-R2 and IC185C-R2 feature the 16850 UART, which uses a 128-byte FIFO buffer for better performance.

The software diskettes (included) contain utilities and a PCMCIA enabler. The enabler helps eliminate compatibility problems. It also helps relocate comm ports if the next available comm port is not desired or possible (due to addressing or interrupt conflicts). Disk 1 of 1 for DOS and Windows 3.1x is labeled "Serial Utility Software SeaCOM DOS, Linux, QNX, Win 3.1x, and Other O/S." Disk 1 of 2 and 2 of 2 for other versions of Windows are labeled "Serial Utility Software SeaCOM Drivers and Utilities for Win 95/98/Me/NT/2000."

The README files on Disk 1 of 1 of the serial utility disks contain information about the latest changes and revisions. To view this file, insert the appropriate diskette into drive A or B and type `A:TYPE README.TXT [ENTER]` or `B:TYPE README.TXT [ENTER]`.

### 2.2 The History of PCMCIA

Most early laptops and notebooks handled I/O expansion through proprietary expansion slots, which worked with only a few specific peripherals such as modems and fax boards. Mass-storage peripherals were factory-installed and could not be easily changed. And the only way to connect to local area networks was through slow parallel-port network interfaces.

In the late 1980s, two standards organizations, JEIDA and PCMCIA, were working on the standardization of memory IC cards. These cards were designed as strictly nonvolatile silicon storage. JEIDA was the first to propose the 68-pin connector standard for memory cards. In 1989 PCMCIA adopted the JEIDA 68-pin standard and worked with JEIDA on further developments. A memory-only interface, PCMCIA Release 1.0, was introduced in September of 1990; it is identical to the JEIDA 4.0 standard.

As the notebook market grew, the need for a standard I/O bus was seen. The PCMCIA groups saw an opportunity to meet this need with an expanded



version of the 68-pin interface. Further development occurred, and within one year Release 2.0 of the standard was completed. Release 2.0 was a major update to Release 1.0; it included full hardware support for I/O devices. Release 2.0 coincided with JEIDA's identical Release 4.1.

### 2.3 What's Included

Your PCMCIA Serial I/O Adapter should come with the following items. If any of these items are missing or damaged, contact Black Box at 724-746-5500.

- (1) PCMCIA Serial I/O Adapter
- Installation software diskettes
- (1) Adapter cable, DB25 male
- (1) DB25-to-DB9 adapter (included with the IC115A-R2 or IC185C-R2 only)
- This manual

### 2.4 Features

Listed below are the special features your PCMCIA Serial I/O Adapter offers.

- Addressable as COM1: (3F8h), COM2: (2F8h), COM3: (3E8h), or COM4: (2E8h).
- No jumper selections or DIP switches required for operation.
- Auto configuration standard for simple installation.
- Speeds to 115 kbps (IC114A-R2 and IC115A-R2) or 460.8 kbps (IC184C-R2 and IC185C-R2).
- Interface cable (included) terminates in DB25 male connector.
- Interface cable secures to PCMCIA card for connection.

### 2.5 System Requirements

This card provides a single serial interface through the PCMCIA interface. It conforms to the PCMCIA Type II (Release 2.01) specification for PC cards and is JEIDA 4.1 compatible.

Prior to installing the card in your system, the Card and Socket Services must be loaded. Card and Socket Services are typically provided by the PCMCIA slot provider (the computer manufacturer or the PC adapter manufacturer).

Socket Services is at the lowest level of the PCMCIA Software hierarchy and provides a standard interface to the higher-level drivers and isolates the hardware-specific details about the socket controller. Socket Services provides the “BIOS” interface to the socket controller hardware. It is typically hidden under Card Services, so it is rarely accessed directly by software clients. Card Services provides the interface to application software and drivers. It is also responsible for allocating card resources and making sure that card resources do not interfere with other existing system resources.

Card Services is typically implemented as a driver and loaded via CONFIG.SYS during bootup. Almost all PCMCIA type cards require some sort of software driver. In the case of the PCMCIA Serial I/O Adapter, the generic Card Services driver provided with your computer system will install the PCMCIA Serial I/O Adapter at the next available COM-port address and interrupt.

Note that the PCMCIA Serial I/O Adapter is not a standard communications port. It is an enhanced device supporting multiple communications protocols not typically supported by standard communication ports.

If you do not want the PCMCIA Serial I/O Adapter installed at the next available COM-port address and interrupt, an “Enabler” is provided with the PCMCIA Serial I/O Adapter that will address unique setup requirements (non-standard I/O addressing, different IRQ selection, etc.). Refer to the **Appendix** for information on the SEAPC enabler.

## 2.6 Technical Description

The PCMCIA Serial I/O Adapter provides one RS-485/422/530 (IC114A-R2 or IC184C-R2) or one RS-232 (IC115A-R2 or IC185C-R2) serial port using the 16550 or 16850 UART (Universal Asynchronous Receiver Transmitter). Both chips feature programmable baud rate, data format, and interrupt control. The IC114A-R2 or IC184C-R2 has a 16-byte input and output FIFO. The IC115A-R2 or IC185C-R2 has a 128-byte FIFO.

### 2.6.1 INTERNAL BAUD-RATE GENERATOR

The PCMCIA Serial I/O Adapter’s baud rate is programmed under software control. The standard oscillator supplied with the board is 1.8432 MHz.

### 2.6.2 COMMUNICATION STANDARDS TECHNICAL REFERENCE

The DB25 male connectors meet the EIA-530 and the RS-232 specification for DTE devices. The following sections contain a brief summary of RS-422, EIA-530, RS-485, and RS-232.

#### *RS-485*

RS-485 is backward-compatible with RS-422; however, it is optimized for party-line or multi-drop applications. The output of the RS-485 driver is capable of being Active (enabled) or Tri-State (disabled). This capability allows multiple

ports to be connected in a multi-drop bus and selectively polled. Half-duplex two-wire operation is also possible by connecting TX+ to RX+ and TX- to RX- in your cable hood. The enable signal to the driver is connected to the UART Request to Send (RTS) line for RS-485 communications. This allows the RS-485 driver to be tri-stated when inactive on a multi-drop polled network. Your software must “know how” to enable the driver (assert RTS) when it is answering a poll.

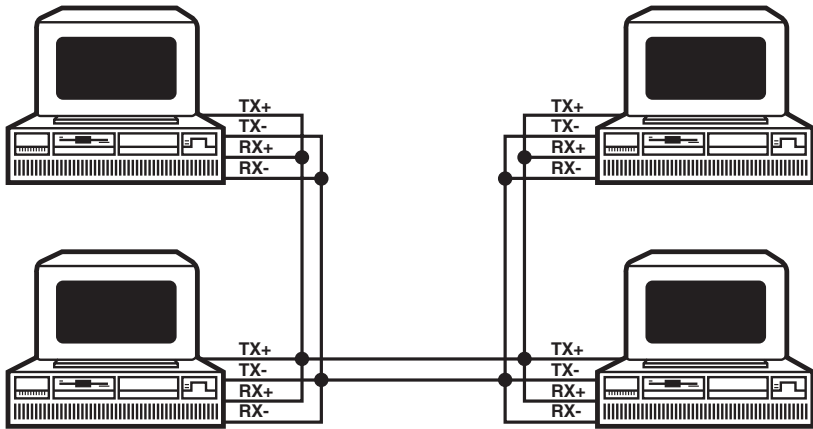

**Figure 2-1. Async RS-485 Half-Duplex Mode Example.**

### ***RS-422***

RS-422 allows very-long-distance (5000 feet or 1524 m at 9600 baud) communications with virtually error-free differential drive characteristics. This is the same electrical standard used with RS-449. Unfortunately, RS-422 did not have a mechanical standard. This oversight means that no standard pinout exists, so each user must customize the interface cable to provide compatibility between RS-422 peripherals.

### ***EIA-530***

EIA-530 compatibility means that RS-422 signal levels are met, and that the mechanical pinout of the DB25 connector is specified. The EIA (Electronic Industry Association) created the EIA-530 specification to detail the pinout. EIA-530 is very similar to RS-449, which calls for RS-449 signals on a DB37 connector. The EIA-530 standard is broken into two interfaces: DTE and DCE, much like RS-232. In addition to the asynchronous modem control signals on a standard PC serial port, EIA-530 specifies Synchronous Clock Signals, Modem Test and Loopback signals. The models IC114A-R2 and

IC184C-R2 have an EIA-530 DTE interface.

**NOTE**

The PCMCIA Serial I/O Adapter is capable of point-to-point RS-422/530 communications if the RTS line is asserted prior to transmitting and released after transmission (RS-485 mode). If this is not acceptable, a simple modification can be accomplished at the factory that allows point-to-point communications regardless of the RTS line (like RS-232).

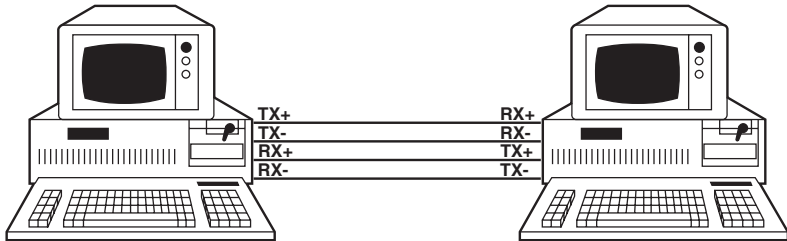

**Figure 2-2. Async RS-422 Full-Duplex Mode Example.**

**Table 2-1. RS-530/422/485 Connector Pinouts,**

Name			Pin #	Mode
GND	Ground	Ground	7	
TDB	TX+	Transmit Positive	14	Output
TDA	TX-	Transmit Negative	2	Output
*RTSB	RTS+	Request To Send Positive	19	Output
*RTSA	RTS-	Request To Send Negative	4	Output
RDB	RX+	Receive Positive	16	Input
RDA	RX-	Receive Negative	3	Input
CTSB	CTS+	Clear To Send Positive	13	Input
CTSA	CTS-	Clear To Send Negative	5	Input

\* The RTS modem control signals are only available if the RS-422/530 modification is completed at the factory.

*RS-232*

## PCMCIA SERIAL I/O ADAPTER

RS-232 has been the de-facto standard for PC communications since the introduction of the IBM® PC. This electrical/mechanical standard is met by PCMCIA Serial I/O Adapter models IC115A-R2 and IC185A-R2 for interfacing standard RS-232 modems, gateways, channel banks, CSUs, DSUs, and a variety of other common communication equipment. The PCMCIA Serial I/O Adapter has an EIA-232 DTE interface.

**Table 2-2. RS-232 Connector Pinouts.**

<b>Name</b>		<b>Pin #</b>	<b>Mode</b>
RD	Receive Data	3	Input
CTS	Clear To Send	5	Input
DCD	Data Carrier Detect	8	Input
DSR	Data Set Ready	6	Input
RI	Ring Indicator	22	Input
RTS	Request To Send	4	Output
DTR	Data Terminal Ready	20	Output
TD	Transmit Data	2	Output
GND	Ground	7	

### 2.6.3 CABLING AND FLOW CONTROL

The cabling configuration that is used with the PCMCIA Serial I/O Adapter will depend on two factors: the handshaking options that are required by your software and the recommended communication standard that is being implemented (that is, RS-232, RS-422, etc.). The following diagrams show typical wiring configurations for commonly used recommended standards. If modem control signals are not used, they should be tied to a fixed logic level. When using a differential interface, like RS-422 or RS-485, each cable connection represented requires two connections. For example, when cabling DTE to DTE, TD+ is connected to RD+ and TD- is connected to RD-. See Figure 2-3.

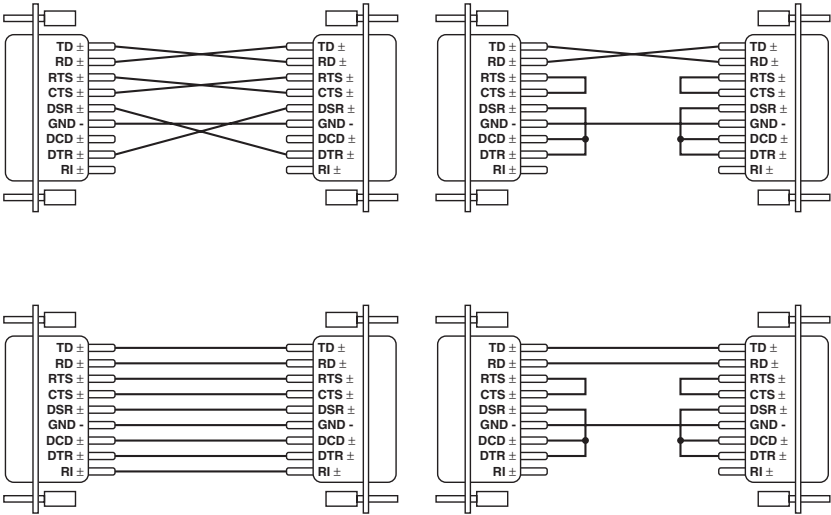

**Figure 2-3. Cabling Examples.**

## 3. Address Selection

### **NOTE**

**Be sure to set the address selection *before* installation.**

The PCMCIA Serial I/O Adapter occupies 8 consecutive I/O locations. These addresses are configured by card and socket services, depending on your system setup and available resources. To modify these default settings, use the supplied enabler. Or, to install the card without card and socket services, use the supplied “SSenable” utility. Refer to the README file on the supplied Diskette 1 of 1, your card and socket services documentation, and the **Appendix** for more information.

# 4. Installation

## IMPORTANT

You must set up the operating system before you physically install the Card.

### 4.1 Setting Up the Operating System

#### 4.1.1 WINDOWS 3.1x

Refer to the Win3x.hlp file in the \Win31 directory on Disk 1 of 1 of the DOS/Windows 3.1x Utilities software. This diskette is labeled “Serial Utility Software SeaCOM DOS, Linux®, QNX, Win3.1x, and Other O/S.”

#### 4.1.2 WINDOWS 95/98/ME/2000/WINDOWS NT USERS

You will use Disks 1 of 2 and 2 of 2. These diskettes are labeled “Serial Utility Software SeaCOM Drivers and Utilities for Win 95/98/Me/NT/2000.” Run setup on Disk 1 of 2 of the Windows 95, 98, Me, 2000, Windows NT serial utilities diskettes before installing the card. Power down the computer and install the adapter. The resources are automatically configured for the PCMCIA card. Refer to the appropriate help file in the Black Box folder located in the **Start, Programs** menu for changing those resources.

#### 4.1.3 DOS

Refer to the Readme.txt file found in the \DOS directory on Disk 1 of 1 of the DOS/Windows 3.1x serial utilities software.

#### 4.1.4 OTHER OPERATING SYSTEMS

Refer to the appropriate directory on Disk 1 of 1 of the DOS/Windows 3.1x serial utilities software.

### 4.2 Hardware Installation

Connecting the PCMCIA Serial I/O Adapter requires no special technical skills. The Adapter can be installed in any PCMCIA Type II-compliant slot of the PC. This slot is keyed so that the PCMCIA Serial I/O Adapter cannot be installed backwards or upside down. The card should fit with a minimal amount of pressure.

## NOTE

**Do not force the card into the slot—this can damage the PCMCIA Serial I/O Adapter or your PCMCIA slot.**



### 4.3 Interface Selection

The PCMCIA Serial I/O Adapter ships, by default, in auto-RS-485 mode with the receiver always turned on. This means that you can use that card as is for RS-422, four-wire RS-485, and two-wire RS-485 echo enabled. Most RS-485 applications do not want echo enabled and that feature should be disabled in software. The included software utility allows for interface selection as well as turning echo off and on.

In Windows 9x, this utility is found in **Device Manager, Ports COM and LPT**.

In Windows NT, the utility is installed as **Advanced Ports** inside the **Control Panel**.

In Windows 2000, the utility can be accessed through **Device Manager, Ports COM and LPT**.

Depending on your operating system, select the PCMCIA Serial I/O Adapter in one of the above locations. Select the **Advance Tab** and look for the **PCMCIA options** section. Here you choose your electrical interface and whether echo is off or on. We recommend that you select, in the PCMCIA section, all the options that apply to your application. Even though, by default, the card will work in RS-422 mode as shipped, we recommend selecting RS-422 mode in the PCMCIA setup if that is what your application uses.

# 5. Troubleshooting

## NOTE

Throughout this manual, the Adapter is sometimes called the Card or the PC Card.

### 5.1 Problems

**Card Services reports that the PC Card cannot be found.**

Possible Cause: The PCMCIA Serial I/O Adapter's internal Card Information Structure (CIS) is not being read correctly by Card Services.

Solution: Use the supplied Client enabler program SEAPC to install the Adapter.

**Card Services or SEAPC successfully allocates the I/O address or IRQ, but the port fails to operate.**

Possible Cause: When using the I/O Client enabler program SEAPC, there is the possibility that the selected I/O address or interrupt is already in use by another adapter in your system. Card Services usually checks for available I/O address during installation or during the boot process. If new hardware or software is installed in the system that may cause an I/O address or IRQ conflict, Card Services may not be able to arbitrate the specified resources.

Solution: Select a different I/O address and IRQ.

**SEAPC will not enable the port at the specified I/O address and interrupt.**

Possible Cause: Card Services flags certain I/O addresses and interrupts as used and will not allow other Client Enabler Drivers, like SEAPC, to use them.

Solution: Select a different I/O address and IRQ in the SEAPC setup file.

**Your host system will not configure the card, or the system shuts down after the PC Card is inserted.**

Possible Cause: Host hardware may not supply enough power to the PCMCIA slot.

Solution: Check to make sure your PCMCIA slot is rated to supply enough power to the card. On some palmtop and battery-powered systems there is a specified limit to the available power a PCMCIA slot can use. If this is the case, try installing the card with the system powered by your AC adapter.

### **Card Services will not respond to card insertion events.**

Possible Cause: Memory conflict, external floppy or hard disks, VGA video cards, SCSI adapters, LAN Network adapters.

Solution: Consult your Card Services documentation for instruction on memory requirements. If you are using DOS, you will probably need to exclude a specified memory range in your CONFIG.SYS file.

### **Adapters that are inserted will not configure properly, or Card Services reports that the card is not recognized.**

Possible Cause: Memory shadowing conflicts.

Solution: Make sure that memory shadowing in your PC is disabled in regions where memory windows are being used by your host PCMCIA adapter.

### **Computer does not recognize any COM ports, or the system is “dead” or unresponsive.**

How to identify the problem: Use the SSD.COM Program (found on your utility diskette).

Solution: Identify all COM ports installed on your computer, and address the PCMCIA Serial I/O Adapter at a different address from those already present.

Reason: Only one device can occupy an address location. If more than one device tries to share an address space, a conflict will occur. This prevents either device from working.

### **The PCMCIA Serial I/O Adapter’s address is not recognized by the system.**

How to identify the problem: Use the SSD.COM Program (found on your utility diskette).

Solution: Verify that the PCMCIA Serial I/O Adapter addresses are correctly set.

Reason: If the board is incorrectly addressed, your application will not respond.

**The PCMCIA Serial I/O Adapter transmits but does not receive. The other side appears to receive, but you do not receive any characters in your application.**

How to identify the problem: Verify that the IRQ is set properly on your PCMCIA Serial I/O Adapter and is correctly set in your application program.

Solution: Change the IRQs so that they are correct.

Reason: Most DOS application programs are “interrupt-driven” on receive. If the IRQ is not set on the card to match those required by your application, it will not receive characters because the interrupt for the first character cannot be serviced.

**When using Windows 3.1, only two ports at any time are functional.**

How to identify the problem: Verify that all ports have a separate interrupt, or if sharing interrupts, only one device is using the IRQ at a time.

Solution: Change the IRQs so that each port has its own unique interrupt (the preferred setting) or close each port before trying to open the next.

Reason: The Windows communication driver does not support simultaneous operation of shared interrupts.

**In Windows 3.1, the mouse hangs or moves erratically.**

How to identify the problem: Verify that the mouse is not sharing an interrupt with any other port or device.

Solution: Change the IRQ of your mouse port so that it does not share an interrupt. Most mice only operate on either COM1 or COM2 using IRQ 4 and 3 respectively. This is a limitation of the mouse driver.

Reason: A mouse is an interrupt “hog.” Any movement or button pressing on the mouse causes an interrupt.

**MSD (Microsoft® Diagnostics) doesn't report the ports on the PCMCIA Serial I/O Adapter.**

How to identify the problem: Verify that the PCMCIA Serial I/O Adapter addresses are correctly set.

Solution: Use the program SETCOM (found on your utility diskette) to install

your additional ports.

Reason: MSD only reports the serial ports found by the BIOS. Older BIOSs install only COM1 or COM2. Newer BIOSs will install up to four ports, but only if the traditional COM port addresses are used.

### 5.2 Calling Black Box

If you determine that your PCMCIA Serial I/O Adapter is malfunctioning, do not attempt to alter or repair the unit. It contains no user-serviceable parts. Contact Black Box at 724-746-5500.

Before you do, make a record of the history of the problem. We will be able to provide more efficient and accurate assistance if you have a complete description, including:

- the nature and duration of the problem.
- when the problem occurs.
- the components involved in the problem.
- any particular application that, when used, appears to create the problem or make it worse.

### 5.3 Shipping and Packaging

If you need to transport or ship your PCMCIA Serial I/O Adapter:

- Package it carefully. We recommend that you use the original container.
- If you are shipping the Adapter for repair, make sure you include everything that came in the original package. If you are returning the Adapter, make sure you include this manual as well. Before you ship, contact Black Box to get a Return Authorization (RA) number.

# Appendix: SEAPC PC Card Client Enabler

## A.1 Overview

SEAPC is a PCMCIA Version 2.0 compliant DOS client that will enable the selected Adapter's I/O address and IRQ when the Adapter is inserted. The SEAPC driver is located on the supplied diskette in the PCMCIA directory. Refer to the README.DOC file for additional information.

SEAPC is not needed in all situations. It should be used if one or more of the following conditions occur:

- The PCMCIA system software (Card and Socket Services) on your host computer will not configure the cards automatically (use "SSenable").
- The PCMCIA system software on your host computer does not supply a configuration utility to allow the Adapter to be configured automatically.
- The configuration utility with the PCMCIA system software does not function properly.

## A.2 SEAPC System Requirements

SEAPC was designed to operate on IBM PC/XT™, AT®, or compatible computers. It requires approximately 3 KB of free conventional memory. If SEAPC is loaded more than once, an additional 3 KB plus buffer space is required for each resident copy. SEAPC may be used with memory managers and loaded into expanded memory. SEAPC requires MS-DOS® or PC-DOS version 3.00 or higher and Card and Socket Services that is compliant with PCMCIA version 2.00 or higher.

## A.3 Installation

### A.3.1 EXECUTING THE DRIVER

SEAPC is a DOS Terminate and Stay Resident (TSR) program that can be executed from the DOS command prompt or from the AUTOEXEC.BAT file. For additional information on the AUTOEXEC.BAT file, refer to your DOS manual. When SEAPC is executed, a setup file must be specified on the command line.

### A.3.2 COMMAND LINE OPTIONS

To display the available command line options, type SEAPC /? at the DOS command prompt. The following message will appear.

```
C:>SEAPC/?
```

```
Syntax: SEAPC [/F:file] [/U] [/I] [/V] [/?]  
/F:[file] Where file is in the configuration file  
/U        Unconditional installation  
/I        Display info on resident copies of SEAPC  
          without installing the enabler  
/V        Show verbose installation information  
/?        Display command line options, inhibit  
          driver from loading.
```

Note that the /F: option is the only required command line parameter. If the setup file is not located in the default directory, the drive and path must be specified. **Section A.3.3** details the syntax of the setup file.

### A.3.3 SETUP FILE

An example setup file named SEAPC.INI is provided on the diskette. This file may be edited with the DOS EDIT utility. The following is the syntax for a PC Card configuration:

```
[card]  
BaseIO=Base I/O address  
IRQ=Interrupt Request Signal  
Type=Device Type  
Interface=Electrical Interface Utilized
```

The table on the next page contains a description of each entry in the setup file.

BaseIO	Base I/O address in hexadecimal. Valid addresses are from 0 to 3FFh. Note that some ranges may be reserved by your PCMCIA system software or occupied by other peripherals in your host computer system.
IRQ	Interrupt Request Signal in decimal. Valid IRQs are from 2 to 15. Note that some IRQs may be reserved by your PCMCIA system software or occupied by other peripherals in your host computer system.
Type	Device Type. Valid options are UART or SCC.
Interface	Electrical Interface Utilized. Valid options are RS-232, RS-422, RS-485. Note that in the scope of the driver, RS-422 and RS-485 are viewed as the same value.

A semicolon (;) at the beginning of a line denotes a comment, and the remainder of that line is ignored. Note that the syntax on the previous page is an example for one card. Multiple cards (up to eight) may be configured using the following syntax:

```
;First Card
[card]
BaseIO=238
IRQ=10
Type=SCC
Interface=RS-232
```

```
;Second Card
[card]
BaseIO=280
IRQ=11
Type=UART
Interface=RS-422
```

#### A.3.4 USING THE PC CARD ON PLATFORMS OTHER THAN ISA

Most PCMCIA systems are based on the standard PC (ISA) architecture; however, in some situations, you may need to install the PC Card in a non-ISA system (for example, Micro Channel<sup>®</sup> or PCI). For this reason the setup file has an additional parameter that allows pulse-mode interrupts. An ISA system would use level-mode interrupts, so this is the default setting. To enable pulse-mode interrupts, add the following line to the setup file:

```
IRQMode=Pulse
```

Keep in mind that this feature will only work if you are using a platform that supports pulse-mode interrupts; the Card and Socket services that you are using support pulse-mode interrupts.





© Copyright 2001. Black Box Corporation. All rights reserved.

---

1000 Park Drive • Lawrence, PA 15055-1018 • 724-746-5500 • Fax 724-746-0746