



**Black Box Corporation**  
*The World's Source for Connectivity™*



**AUGUST 1997**  
**FX132A**

# LineShare Pro 103

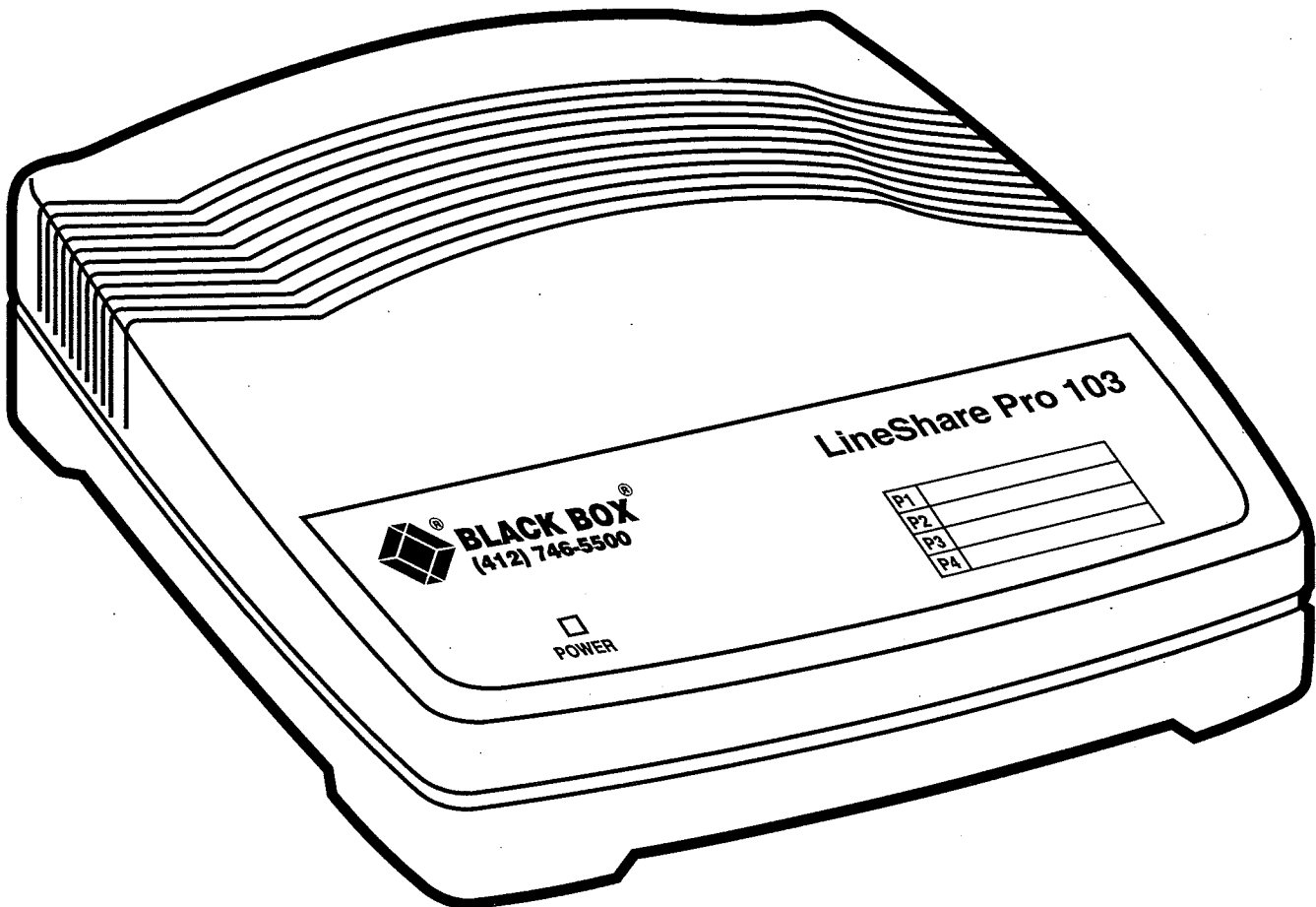

**CUSTOMER  
SUPPORT  
INFORMATION**

To order or for technical support: Call (412) 746-5500 or fax (412) 746-0746  
Technical support and fax orders 24 hours a day, 7 days a week  
Phone orders 24 hours, 8 A.M. Monday to midnight Friday; Saturday 8 to 4 (Eastern)  
Mail order: **Black Box Corporation**, P.O. Box 12800, Pittsburgh, PA 15241

**FEDERAL COMMUNICATIONS COMMISSION  
and CANADIAN DEPARTMENT OF COMMUNICATIONS  
RADIO FREQUENCY INTERFERENCE STATEMENT**

**Class B Digital Device.** This equipment has been tested and found to comply with the limits for a Class B computing device pursuant to Part 15 of the FCC Rules. These limits are designed to provide reasonable protection against harmful interference in a residential installation. However, there is no guarantee that interference will not occur in a particular installation. This equipment generates, uses, and can radiate radio frequency energy, and, if not installed and used in accordance with the instructions, may cause harmful interference to radio communications. If this equipment does cause harmful interference to radio or telephone reception, which can be determined by turning the equipment off and on, the user is encouraged to try to correct the interference by one of the following measures:

- Reorient or relocate the receiving antenna.
- Increase the separation between the equipment and receiver.
- Connect the equipment into an outlet on a circuit different from that to which the receiver is connected.
- Consult an experienced radio/TV technician for help.

**Caution:**

**Changes or modifications not expressly approved by the party responsible for compliance could void the user's authority to operate the equipment.**

To meet FCC requirements, shielded cables and power cords are required to connect this device to a personal computer or other Class B certified device.

*This digital apparatus does not exceed the Class B limits for radio noise emission from digital apparatus set out in the Radio Interference Regulation of the Canadian Department of Communications.*

*Le présent appareil numérique n'émet pas de bruits radioélectriques dépassant les limites applicables aux appareils numériques de classe B prescrites dans le Règlement sur le brouillage radioélectrique publié par le ministère des Communications du Canada.*

**NORMAS OFICIALES MEXICANAS (NOM)  
ELECTRICAL SAFETY STATEMENT**

**INSTRUCCIONES DE SEGURIDAD**

1. Todas las instrucciones de seguridad y operación deberán ser leídas antes de que el aparato eléctrico sea operado.
2. Las instrucciones de seguridad y operación deberán ser guardadas para referencia futura.
3. Todas las advertencias en el aparato eléctrico y en sus instrucciones de operación deben ser respetadas.
4. Todas las instrucciones de operación y uso deben ser seguidas.
5. El aparato eléctrico no deberá ser usado cerca del agua—por ejemplo, cerca de la tina de baño, lavabo, sótano mojado o cerca de una alberca, etc.
6. El aparato eléctrico debe ser usado únicamente con carritos o pedestales que sean recomendados por el fabricante.
7. El aparato eléctrico debe ser montado a la pared o al techo sólo como sea recomendado por el fabricante.
8. Servicio—El usuario no debe intentar dar servicio al equipo eléctrico más allá a lo descrito en las instrucciones de operación. Todo otro servicio deberá ser referido a personal de servicio calificado.
9. El aparato eléctrico debe ser situado de tal manera que su posición no interfiera su uso. La colocación del aparato eléctrico sobre una cama, sofá, alfombra o superficie similar puede bloquea la ventilación, no se debe colocar en libreros o gabinetes que impidan el flujo de aire por los orificios de ventilación.
10. El equipo eléctrico deber ser situado fuera del alcance de fuentes de calor como radiadores, registros de calor, estufas u otros aparatos (incluyendo amplificadores) que producen calor.
11. El aparato eléctrico deberá ser conectado a una fuente de poder sólo del tipo descrito en el instructivo de operación, o como se indique en el aparato.
12. Precaución debe ser tomada de tal manera que la tierra física y la polarización del equipo no sea eliminada.

13. Los cables de la fuente de poder deben ser guiados de tal manera que no sean pisados ni pellizcados por objetos colocados sobre o contra ellos, poniendo particular atención a los contactos y receptáculos donde salen del aparato.
14. El equipo eléctrico debe ser limpiado únicamente de acuerdo a las recomendaciones del fabricante.
15. En caso de existir, una antena externa deberá ser localizada lejos de las líneas de energía.
16. El cable de corriente deberá ser desconectado del cuando el equipo no sea usado por un largo periodo de tiempo.
17. Cuidado debe ser tomado de tal manera que objetos líquidos no sean derramados sobre la cubierta u orificios de ventilación.
18. Servicio por personal calificado deberá ser provisto cuando:
  - A: El cable de poder o el contacto ha sido dañado; u
  - B: Objetos han caído o líquido ha sido derramado dentro del aparato; o
  - C: El aparato ha sido expuesto a la lluvia; o
  - D: El aparato parece no operar normalmente o muestra un cambio en su desempeño; o
  - E: El aparato ha sido tirado o su cubierta ha sido dañada.

# Table of Contents

## INTRODUCTION

Introducing the LineShare Pro 103 .....	2
Before you begin .....	2
A note about telephone company services .....	2
Selecting your set-up .....	3

## INSTALLATION

Installing the LineShare Pro 103 .....	4
Placing the LineShare Pro 103 .....	4
Ports on the LineShare Pro 103 .....	4
Connecting the LineShare Pro 103 .....	5
Installation with a single line telephone .....	5
Installation at the DEMARC .....	6
Installation on a telephone system .....	7
Installation on a telephone system using a 66 block ...	7

## OPERATION

Operating modes .....	8
Automatic mode .....	8
Semi-Automatic mode .....	9
Distinctive Ring service .....	10
Automatic mode .....	10
Semi-Automatic mode .....	11
Using the LineShare Pro 103 .....	11
Special operating notes .....	11
Answering incoming calls .....	12
Answering calls with an answering machine .....	12
Retrieving answering machine messages from a remote location .....	12
Placing an outbound call .....	13
Receiving a computer call .....	13
Dialing the destination (receiving computer through the originating (calling) computer .....	13
ComScan <sup>®</sup> Scanning / Intercom .....	14
Remote Message Notification .....	14

## PROGRAMMING

Programming the LineShare Pro 103 .....	15
Introduction .....	15
Entering and programming locally .....	15
Entering and programming remotely .....	16
Remote Message Notification programming .....	16
Technical Support programming .....	16
Programmable features of the LineShare Pro 103 ...	17
Programmable feature settings of the LineShare Pro 103 ..	18
Extension Detection .....	19
Answer Any Port .....	19
Automatic Port P1 Transfer .....	20
Automatic No Answer Transfer .....	20
Outbound Voice Exclusion .....	21
Automatic Ring Reduction .....	21
Automatic Ring Reduction Reset .....	22
Caller ID .....	22
Remote Message Notification .....	23
Pound Key Transfer Required .....	23
Pulse Dial Transfer .....	24
Distinctive Ring Service Detection .....	24
Single Tone Detection .....	25
Fax CNG (Calling) Tone Detection .....	25
Modem Calling Tone Detection .....	26
Reverse Modem Tone Detection .....	26
ComScan Scanning .....	27
Automatic Port Transfer Selection .....	28
Unlimited Port Transfer .....	28
Operating Mode .....	28
Rings to Answer Call .....	29
Rings to Ports P1 and P2 .....	29
Rings to Port P3 .....	30
Rings to Port P4 .....	30
Remote Security Access Code .....	31
Ports P1 and P2 Transfer Code .....	31
Port P3 Transfer Code .....	31
Port P4 Transfer Code .....	32
DRS Assignment .....	32
Phantom Ring Style .....	33
Port Tone Assignment .....	33
RMN Conditions .....	34
RMN Phone Number .....	35
Single Tone Detection Timer .....	35
Ring Reduction Reset Timer .....	36
Port P1 Transfer Timer .....	36
Unlimited Port Transfer Timer .....	36
Scanning Timer .....	37
Reset to Factory Settings .....	37

**Thank You for purchasing this Black Box product!**

## Introducing the **LineShare Pro 103**

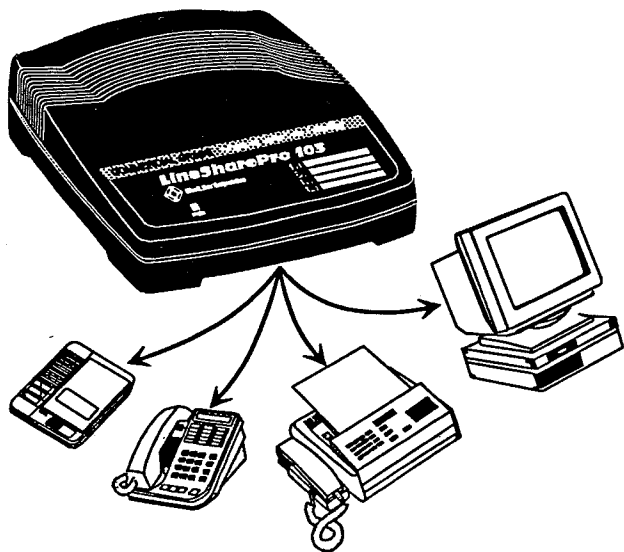

The LineShare Pro 103 is a phone line management system designed to direct incoming phone calls to 1 of 4 destinations (typically a phone, answering machine, fax machine and a computer modem.) It is also capable of transferring calls to any of the following devices:

- Credit card authorization terminal
- Security alarm and monitoring system
- Money order dispensing system
- Bulletin Board System (BBS)
- Call diverter
- Laser fax cartridge
- Energy management system
- Flow monitoring system
- Time and attendance system
- Fluid storage system
- Point-of-sale terminal
- Remote diagnostic system

### Before you begin

- Complete and *mail* the enclosed warranty card.
- Read through this guide and choose the installation which best fits your needs.
- Unpack and check for the following items.

If any of these items are missing or damaged, contact the dealer where you purchased the unit, or call Customer Service at: (412) 746-5500.

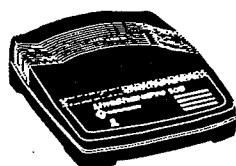

1 LineShare Pro 103



1 AC power adapter

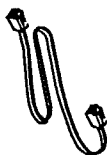

1 modular telephone line cord

1 warranty card



#### Installation Kit

- 1 mounting template
- 1 modular connector
- 1 installer reply card
- 2 mounting screws

### A note about telephone company services





If you currently subscribe to or plan to subscribe to any of these services, please note the following:

- Call Waiting:** Fax machine and modem transmissions may be disrupted by the call waiting signal, unless Call Waiting is disabled. It can be disabled on a single call by pressing \*70 before dialing a phone number.
- Call Forwarding:** If this service is activated, the LineShare Pro 103 cannot process incoming calls.
- Phone Company Voice Mail:** Is compatible only when phone company Distinctive Ring service is activated.

# Selecting your set-up

The LineShare Pro 103 is a single line device that can be installed on any type of modular or non-modular system that consists of one or more lines, with one or more phones.

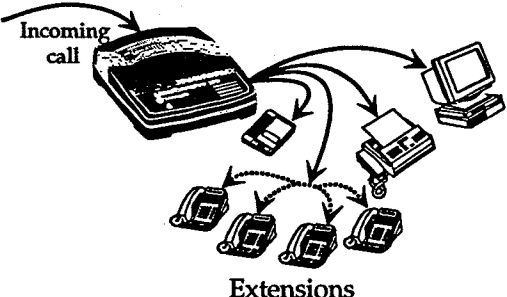
The LineShare Pro 103 has 2 operating modes, Automatic, Semi-Automatic and can be connected in 3 separate configurations as follows:

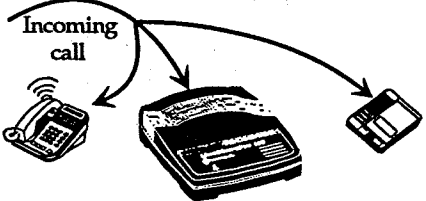
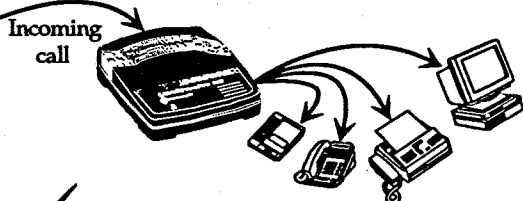
<p>Standard set-up</p> 	<p><b>Automatic operation</b> (calls are answered and processed for the entire location)</p> 	<p><b>NOTE</b> This application requires installation at the DEMARC. See installing the LineShare Pro 103 for more information.</p>
	 <p style="text-align: center;">Extensions</p>	<ul style="list-style-type: none"> <li><input checked="" type="checkbox"/> Answers... the call automatically.</li> <li><input checked="" type="checkbox"/> Transfers... voice calls to your phone and answering machine (all phones on the line).</li> <li><input checked="" type="checkbox"/> Transfers... fax calls to your fax machine if a fax tone is present, or to the computer modem if access codes are used.</li> </ul>
	<p><b>Semi-Automatic operation</b> (all phones in the home ring)</p> 	<p><b>Automatic operation</b> (calls are answered and processed where the LineShare Pro 103 is located)</p> 
		
	<ul style="list-style-type: none"> <li><input checked="" type="checkbox"/> Waits... for <u>you or your answering machine</u> to answer the call.</li> <li><input checked="" type="checkbox"/> Listens... for fax tones or computer access codes.</li> <li><input checked="" type="checkbox"/> Transfers... fax calls to your fax machine if a fax tone is present, or to the computer modem if access codes are used.</li> </ul>	<ul style="list-style-type: none"> <li><input checked="" type="checkbox"/> Answers... the call automatically.</li> <li><input checked="" type="checkbox"/> Transfers... voice calls to your phone and answering machine (connected to the LineShare Pro 103).</li> <li><input checked="" type="checkbox"/> Transfers... fax calls to your fax machine if a fax tone is present, or to the computer modem if access codes are used.</li> </ul>

Once you select your set-up, proceed with connecting the LineShare Pro 103. For more information on operating procedures, see "Using the LineShare Pro 103."

# Installing the LineShare Pro 103

## Placing the LineShare Pro 103

The LineShare Pro 103 can be mounted on a wall with the connected telephone line cords above or below the unit. You can place the telephone line cords through the line guides on the back of the LineShare Pro 103 to reduce tangling.

**NOTE**

Do not place the LineShare Pro 103 in close proximity to any peripheral equipment (approximately 2 to 3 feet away from all electronic equipment).

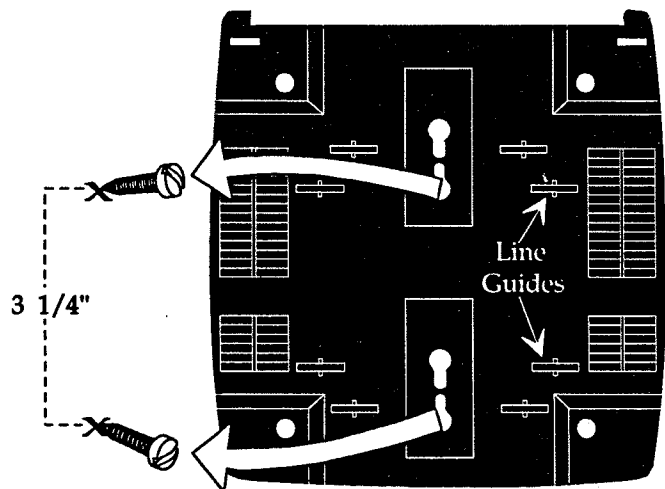

## Ports on the LineShare Pro 103

The rear panel of the LineShare Pro 103 includes five (5) modular ports and a power input port, as shown:

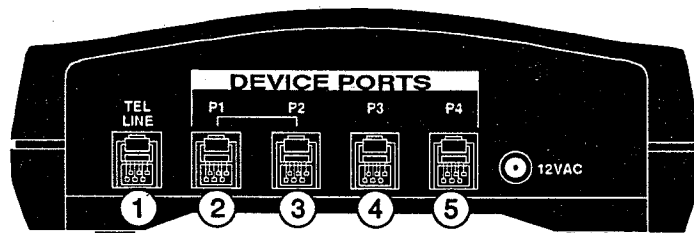

A typical installation (voice, fax, computer) would connect telephone equipment as follows:

- ① Connect the provided modular line cord from a standard telephone (wall) jack to this port.
- ② Connect an answering machine or integrated phone/answering machine to this port. The LineShare Pro 103 will transfer all voice calls to ports P1 and P2 simultaneously.
- ③ Depending on the installation, a single line telephone, an integrated phone/answering machine, multiple phones, or a telephone system (KSU or PBX) can be connected to this port. The LineShare Pro 103 will transfer all voice calls to ports P1 and P2 simultaneously.
- ④ Connect your fax machine to port P3. A computer modem or fax/modem can connect to this port in lieu of a fax machine.
- ⑤ A computer modem or fax/modem can connect to port P4 to enable the LineShare Pro 103 to transfer a modem call with the appropriate transfer codes.

# Connecting the LineShare Pro 103

This section explains how to install the LineShare Pro 103 in most phone configurations that appear in a home or office.

You can install the LineShare Pro 103 into one of the following phone configurations:

- a single telephone line
- a telephone system

Installation procedures for each of these configurations are provided in the following sections.

## Installation with a single line telephone

The following diagram shows a typical installation with a single line telephone. While the connections to the telephone (wall) jack may be different for other types of phone systems, the connections to the LineShare Pro 103 remain the same for most phone configurations.

This installation is for use in the Semi-Automatic mode, or for the Automatic mode with a phone connected to port P2. (Phones not connected to port P2 in the Automatic mode will ring only 1 time on an inbound call. See "Installation at the DEMARC" for an alternate installation.)

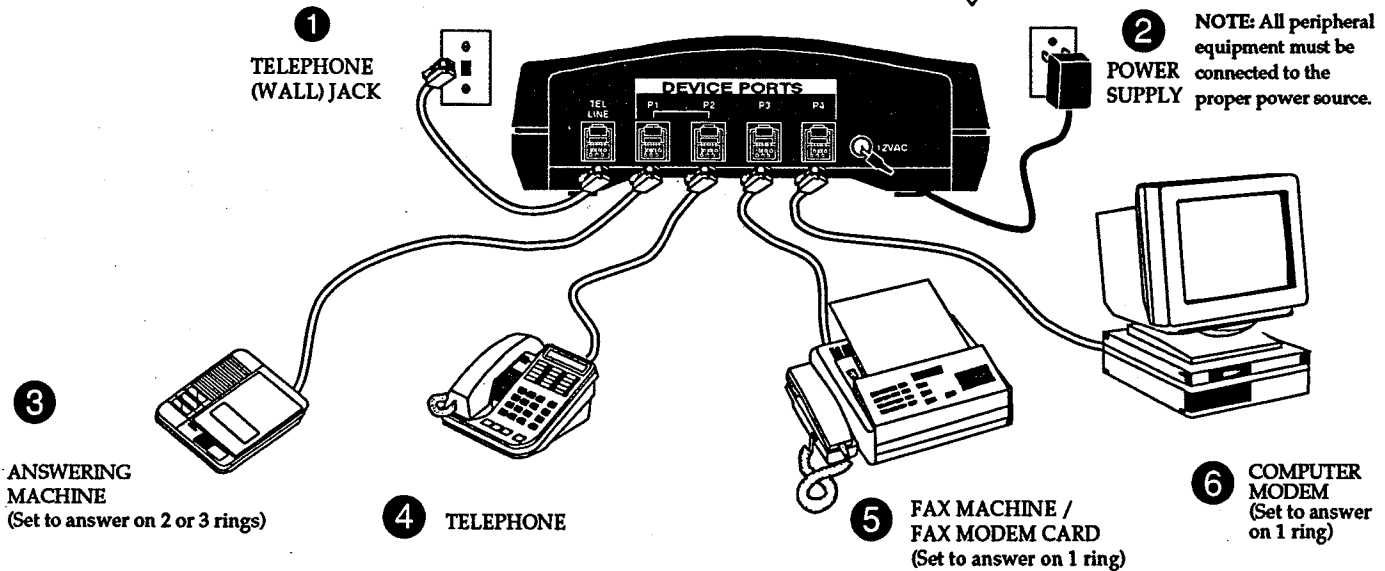

NOTE

To connect a Caller ID device to the LineShare Pro 103, simply plug the Caller ID into port P2, then plug the phone into the Caller ID.

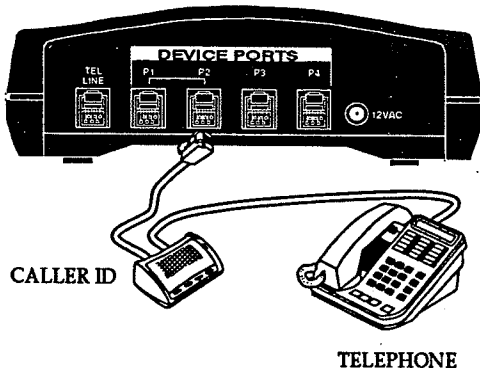

The factory setting for Caller ID operation is OFF. See "Programmable features of the LineShare Pro 103" for more information.



# Installation at the DEMARC

The following diagram shows an installation at the point of DEMARC on line 1. Once connected in this configuration, the telephones will never ring on an inbound call if the LineShare Pro 103 transfers to either port P3 or port P4. Only calls that do not produce transfer tones will ring the telephones.

**SINGLE LINE INSTALLATION ON LINE 1**

For use in the Automatic mode to allow the LineShare Pro 103 control over all phones on the line.

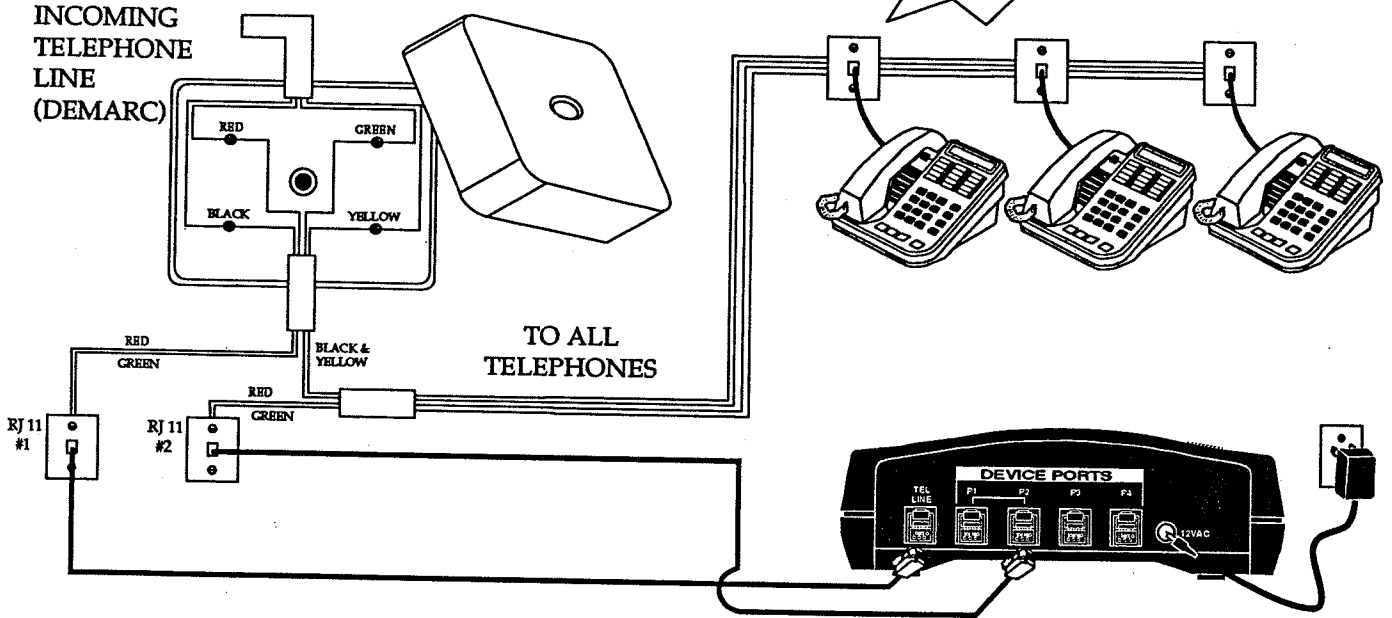

**SINGLE LINE INSTALLATION ON LINE 2**

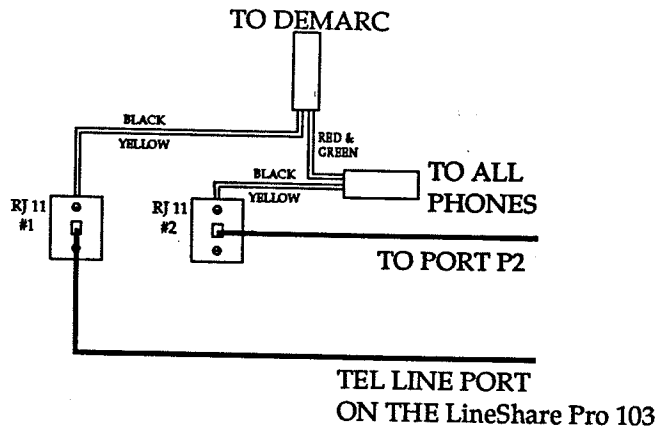

## Installation on a telephone system

The diagram shows telephone devices connected to the LineShare Pro 103 for a telephone system; follow the same procedures for a mini-telephone system. For the LineShare Pro 103 to operate properly, it must be "in front" of the telephone system. Connect the other equipment as previously shown.

All equipment on that line (telephone system, fax, computer modem, and so on) must connect directly to the LineShare Pro 103.

**CAUTION** Do not plug the LineShare Pro 103 into a telephone system phone jack. You may damage the phone system or the LineShare Pro 103.

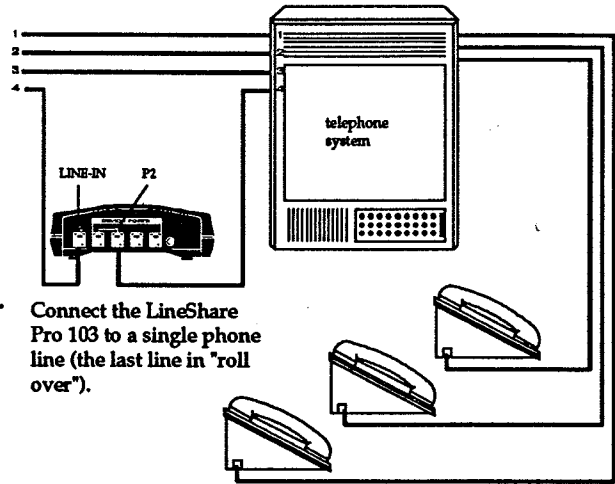

## Installation on a telephone system using a 66 block

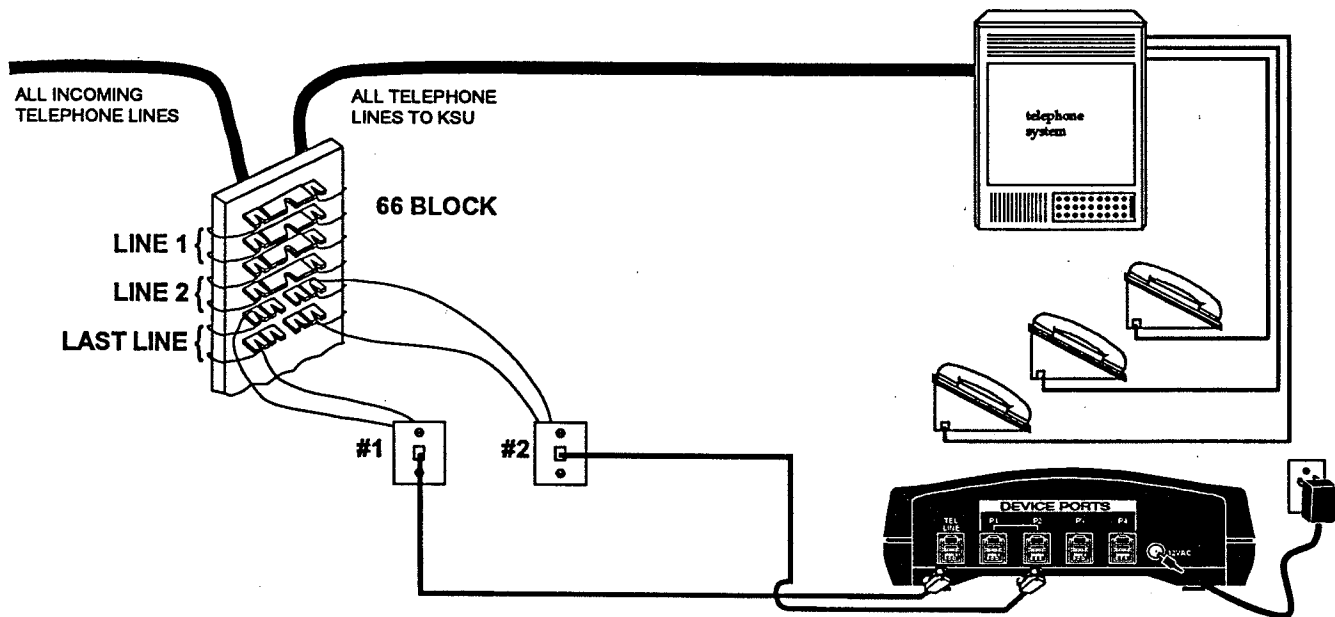

# Operating modes

## Automatic mode

The LineShare Pro 103 prohibits incoming calls from direct access to any connected device (unless Caller ID is ON). The LineShare Pro 103 will answer the call on the first ring (Rings to Answer Call). Once the call is answered, the LineShare Pro 103 listens (Single Tone Detection) for the following signals:

- 1100Hz CNG tone (if turned ON)
- access code for port P3 # 2 2
- access code for port P4 # 3 3
- 2225Hz Reverse Modem tone (if turned ON)
- 1300Hz Modem calling tone (if turned ON)

If the LineShare Pro 103 detects any of these signals, it transfers the call to port P3 or P4.

After 4 seconds, the call will be transferred to ports P1 and P2 if tones are not detected.

The LineShare Pro 103 will ring ports P1 and P2 up to 6 times (Rings to ports P1 and P2). If the call remains unanswered after 6 rings (Rings to ports P1 and P2), the LineShare Pro 103 will transfer (Automatic No Answer Transfer) the call to port P3 (Automatic Port Transfer Selection).

If the LineShare Pro 103 transfers an unanswered call to port P3, it will automatically reduce the number of rings to the telephones connected to ports P1 and P2 to 2 rings (Automatic Ring Reduction) to ensure optimum connect time.

The LineShare Pro 103 will reset the ring count to 6 rings (Ring Reduction Reset) after 10 minutes (Ring Reduction Reset Timer) of inactivity on port P3. The LineShare Pro 103 can also be manually reset by performing any of the following steps:

- Lift the receiver of any phone device on the line
- Place an outbound call from any phone on the line connected to the LineShare Pro 103 and hang it up.
- Answer a call from any phone before the call is transferred to port P3.

If a device connected to port P1 or P2 answers a call, the LineShare Pro 103 will disable the Single Tone Detection feature (if the Single Tone Detection Timer has not expired). Then only tone and pulse transfers are allowed as follows.

- port P3 # 2 2 tone 3 pulse
- port P4 # 3 3 tone 4 pulse

In the Automatic mode, pulse transfers are allowed from phones connected directly to the LineShare Pro 103. The device calling into the LineShare Pro 103 cannot pulse transfer to a port on the LineShare Pro 103.

After a call has been transferred to port P3 or P4, it can be transferred back to ports P1 and P2 by pressing # 1 1 or 5 pulse.

Any time a call is transferred to another port, the port that is off-hook with the call is the only port that will be allowed to transfer the call. The originating port will receive a busy tone once the transfer occurs.

To accommodate faxes that do not produce CNG tones, the Automatic Port P1 Transfer feature can transfer a call to port P3 or P4 when the answering machine disconnects from a call. The factory setting for this feature is OFF, and uses the Port P1 Transfer Timer to set parameters for transfer as described later in this guide.

The factory setting for the LineShare Pro 103 is the Automatic mode. To change the operating mode, see "Programmable features of the LineShare Pro 103" for more information.

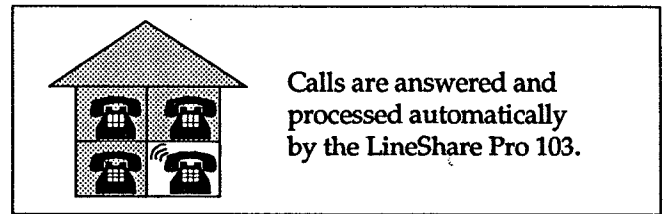

NOTE

Extension phones not connected to the LineShare Pro 103 will only ring one time on inbound calls and do not have complete access to the phone line unless Extension Detection is turned ON.

## Semi-Automatic mode

The LineShare Pro 103 allows incoming calls to simultaneously ring extension phones and the phone/answering machine connected to the LineShare Pro 103. The LineShare Pro 103 will not answer the call, it simply waits for the answering machine or any phone to answer. Once a call is answered, the LineShare Pro 103 listens (Single Tone Detection) for the following signals:

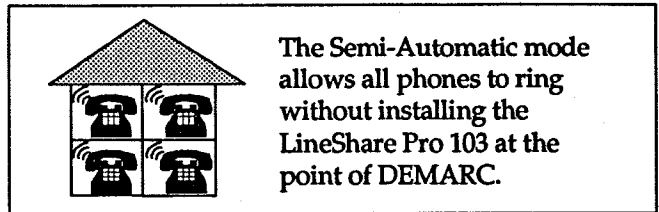

- 1100 Hz CNG tone (if turned ON)
- access code for port P3 # 2 2
- access code for port P4 # 3 3
- 2225Hz reverse modem tone (if turned ON)
- 1300Hz modem calling tone (if turned ON)

If the LineShare Pro 103 detects any of these signals (within the 10 second Single Tone Detection Timer), it transfers the call to port P3 or P4 accordingly.

The LineShare Pro 103 will allow up to 6 rings for the call to be answered (Rings to Ports P1 and P2). If the call remains unanswered after 6 rings, the LineShare Pro 103 will transfer (Automatic No Answer Transfer) the call to port P3 (Automatic Port Transfer Selection).

If the LineShare Pro 103 transfers an unanswered call to port P3, it will automatically reduce the number of rings to answer a call to 2 rings (Automatic Ring Reduction) to ensure optimum connect time.

The LineShare Pro 103 will reset (Ring Reduction Reset) the ring count to 6 rings (Rings to Ports P1 and P2) after 10 minutes (Ring Reduction Reset Timer) of inactivity on port P3. The LineShare Pro 103 can also be manually reset to 6 rings by performing any of the following steps:

- Lift the receiver of any phone device on the line connected to the LineShare Pro 103 and hang it up.
- Place an outbound call from any phone on the line connected to the LineShare Pro 103.
- Answer a call from any phone before the call is transferred to port P3.

If a device connected to port P3 or P4 answers a call, only tone and pulse transfers are allowed as follows.

- ports P1 and P2 # 1 1 tone 5 pulse
- port P3 # 2 2 tone 3 pulse
- port P4 # 3 3 tone 4 pulse

In the Semi-Automatic mode, pulse transfers are allowed from any phone connected to the line using the LineShare Pro 103. The device calling into the LineShare Pro 103 cannot pulse transfer to a port on the LineShare Pro 103.

Any time a call is transferred to another port, the port that is off-hook with the call is the only port that will be allowed to transfer the call. The originating port will receive a busy tone after the transfer occurs.

To accommodate faxes that do not produce CNG tones, the Automatic Port P1 Transfer feature can transfer a call to port P3 or P4 when the answering machine disconnects from a call. The factory setting for this feature is OFF, and uses the Port P1 Transfer Timer to set parameters for transfer as described later in this guide.

The factory setting for the LineShare Pro 103 is the Automatic mode. To change the operating mode, see "Programmable features of the LineShare Pro 103" for more information.

## Distinctive Ring service

The phone company's Distinctive Ring service (DRS) is offered in most areas across the U.S. Phone companies offer this service under various names, check with your local phone company for details.

When a second or third phone number is added to a single line, the LineShare Pro 103 works smoothly to process calls without depending on access codes or transfer tones.

The factory default for Distinctive Ring detection is OFF. When turned ON, the LineShare Pro 103 will process the additional phone numbers (ring styles) as follows:

- standard ring ----- ports P1 and P2
- two-burst ring ----- port P3
- three-burst ring ----- port P4

(These settings are the default settings for transferring calls, and can be changed to meet end-user needs.)

When Distinctive Ring is turned ON, the following features are deactivated:

- Automatic Port P1 Transfer
- Automatic No Answer Transfer
- Automatic Ring Reduction

When Distinctive Ring is turned ON, the LineShare Pro 103 will process calls in the current operating mode. Calls will be processed differently in the Automatic mode and Semi-Automatic mode as follows:

### Automatic mode (DRS Activated)

The LineShare Pro 103 prohibits incoming calls from direct access to any connected device (unless Caller ID is ON). The LineShare Pro 103 will answer the call on the first ring (Rings to Answer Call) unless the DRS Assignment is not set for that line. (This means the LineShare Pro 103 will only process distinctive rings which have been programmed and ignore all other ring styles.) Once the call is answered, the LineShare Pro 103 will listen for the following signals:

- 1100Hz CNG tone (if turned ON)
- access code for port P3 # 2 2
- access code for port P4 # 3 3
- 2225Hz reverse modem tone (if turned ON)
- 1300Hz modem calling tone (if turned ON)

If the LineShare Pro 103 detects any of these signals, it transfers the call to port P3 or P4.

If the LineShare Pro 103 does not detect any of these signals, it will transfer the call to the appropriate port as designated in the DRS Assignment.

If a device connected to port P3 or P4 on the LineShare Pro 103 answers a call, the LineShare Pro 103 will disable the Single Tone Detection feature (if the associated timer has not expired). Then only tone and pulse transfers are allowed as follows.

- ports P1 and P2 # 1 1 tone 5 pulse
- port P3 # 2 2 tone 3 pulse
- port P4 # 3 3 tone 4 pulse

In the Automatic mode, pulse transfers are allowed from phones connected directly to the LineShare Pro 103. The device calling into the LineShare Pro 103 cannot pulse transfer to a port on the LineShare Pro 103.

Any time a call is transferred to another port, the port that is off-hook with the call is the only port that will be allowed to transfer the call. The originating port will receive a busy tone once the transfer occurs.

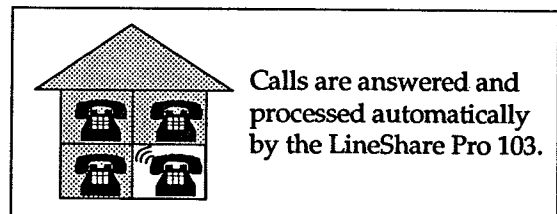

NOTE

Extension phones not connected to the LineShare Pro 103 will only ring one time (Rings to Answer Call) on inbound calls and do not have complete access to the phone line unless Extension Detection is turned ON.

## Semi-Automatic mode (DRS activated)

The LineShare Pro 103 allows incoming calls to simultaneously ring extension phones and the phone/answering machine connected to the LineShare Pro 103. The LineShare Pro 103 will suppress the first incoming ring from passing through to ports P1 and P2. The second ring will be transferred to the appropriate port as designated in the DRS Assignment. The LineShare Pro 103 will not answer the call, it simply waits for the call to be answered. Once a device connected to the LineShare Pro 103 answers a call, it listens for the following signals:

- 1100Hz CNG tone (if turned ON)
- access code for port P3 # 2 2
- access code for port P4 # 3 3
- 2225Hz reverse modem tone (if turned ON)
- 1300Hz modem calling tone (if turned ON)

If the LineShare Pro 103 detects any of these signals, it transfers the call to port P3 or P4. Otherwise, it remains on line until it receives transfer codes, or the call disconnects.

If a device connected to any port answers a call, the **Single Tone Detection** feature activates. When the **Single Tone Transfer Timer** expires (10 seconds), only tone and pulse transfers are allowed as follows.

- ports P1 and P2 # 1 1 tone 5 pulse
- port P3 # 2 2 tone 3 pulse
- port P4 # 3 3 tone 4 pulse

In the Semi-Automatic mode, pulse transfers are allowed from any phone connected to the line using the LineShare Pro 103. The device calling the LineShare Pro 103 cannot pulse transfer to a port on the LineShare Pro 103.

Any time a call is transferred to another port, the port that is off-hook with the call is the only port that will be allowed to transfer the call. The originating port will receive a busy tone once the transfer occurs.

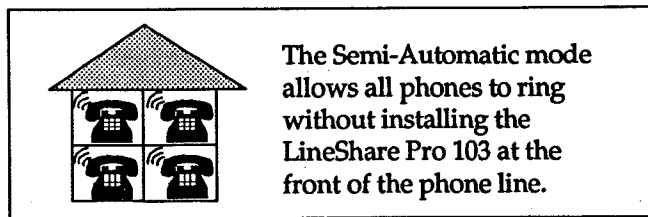

## Using the LineShare Pro 103

### Special operating notes

Before operating the LineShare Pro 103, be sure that you understand the following information concerning the telephone equipment that is used with the LineShare Pro 103.

**Fax CNG tones:** Most faxes send audible beep tones called CNG (Calling) tones. This tone is a distinct beep that repeats every three (3) seconds. Once a fax has dialed the destination fax number, it generates this tone while waiting for the receiving fax to answer.



Beep Beep Beep

Not all faxes transmit this tone when they place a call. Most, but not all faxes produce this tone through their auto-dial feature, speed-dial memory position, or by the operator pressing the fax machine's *start* button after the number is dialed.

For best results, callers should have your fax number programmed into their fax machine's "speed-dial" memory.

## Answering incoming calls



You can answer incoming calls from an extension phone or from a phone device connected to port P1 or P2. You can then conduct the call normally, for as long as you like.

- ① If, after answering a call, you hear silence on the line, the call is likely coming from a fax that does not produce a CNG tone. Simply transfer the call to port P3 by entering **# 2 2** from a tone phone or **3** from a rotary/pulse dialing phone.
- ② To transfer a caller that requests port P3, press **# 2 2** from a tone phone or **3** from a rotary/pulse dialing phone.

To transfer calls to port P4, press **# 3 3** from a tone phone or **4** from a rotary/pulse dialing phone.

- ③ In the Semi-Automatic mode, if you hear a CNG tone or an access code for port P3 or P4 after answering a call, hang up the phone once the device answers.

**NOTE** If the LineShare Pro 103 is in the Automatic mode, you cannot perform rotary/pulse dialing transfers from extension phones not connected to the LineShare Pro 103.

## Answering calls with an answering machine

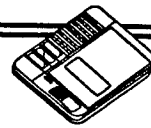

If the answering machine answers a call from port P1, the caller can perform the following tasks:

- record a voice message on the answering machine and/or
- transfer their call to port P3 or P4

Following is a sample announcement message that you may wish to use:

" \* Hello, this is \_\_\_\_\_. If you wish to send a fax, press **# 2 2** on your tone phone, or leave a message at the tone."

**NOTE** Callers cannot transfer a call to port P3 or port P4 from a pulse dialing fax.

\* If the LineShare Pro 103 is in the Semi-Automatic mode, you should record 4 seconds of silence before recording your outgoing message.

**NOTE** Fax calls that do not produce a CNG tone will transfer to the answering machine. To allow the LineShare Pro 103 to transfer these calls to port P3 (Port Transfer Selection), see "Programmable features of the LineShare Pro 103" to turn on the Automatic Port P1 Transfer feature.

With this feature turned ON, the LineShare Pro 103 will monitor the line for 30 seconds after the answering machine answers a call. If the answering machine disconnects from the call during this time, the LineShare Pro 103 automatically transfers the call to port P3 (Port Transfer Selection). To accommodate these timing parameters, the outgoing message should be between 15 and 20 seconds in length. (Single cassette answering machines are not recommended for use with this feature due to timing limitations of these types of machines.)

## Retrieving answering machine messages from a remote location

To disable the LineShare Pro 103 and retrieve answering machine messages, follow these steps:

- ① Dial your phone number and wait for the answering machine to answer the call.
- ② After the answering machine answers the call, press **\*** from a tone phone.
- ③ Follow the remote retrieval procedures for your answering machine.
- ④ After retrieving your messages, hang up. The LineShare Pro 103 resets for the next call.

---

## Placing an outbound call



Outbound calls can be placed from port P2. If another port is in use, the LineShare Pro 103 will produce a busy signal when attempting to place a call.

During an outbound call, you can also receive a transmission from someone that is ready to transmit.

To transfer this call to port P3, any time during a conversation, press **# 2 2** from a tone phone, or **3** from a rotary/pulse dialing phone.

To transfer this call to port P4, any time during a conversation, press **# 3 3** from a tone phone, or **4** from a rotary/pulse dialing phone. Rotary/pulse transfers are not possible until 20 seconds after dialing the last digit of the phone number.

(Picking up an extension phone not connected to port P1 or P2 during a data or fax transmission may interrupt the call.)

---

## Receiving a computer call

Unlike a fax call, most inbound computer calls do not produce identifying tones; they remain silent until another modem answers the call.



To receive a computer call to port P4, instruct the caller to use one of the following methods. (In this example we use a modem.)

---

## Dialing the destination (receiving) computer through the originating (calling) computer

To have the calling modem automatically "over dial" the port P4 access code and access the modem connected to the LineShare Pro 103, the caller must take into consideration whether the call is local or long distance.

For remote access to port P4 on the LineShare Pro 103, instruct the caller to use the following dialing string in the modem's software:

ATDT (phone number),#33,#33,#33,#33  
(for Automatic mode)

ATDT (phone number),,,#33,#33,#33,#33  
(for Semi-Automatic mode)

The calling modem picks up its phone line and dials the phone number. The comma (,) tells the modem to wait about two (2) seconds and then repeatedly "over dial" the access code.

**NOTE** Not all modem comma (,) commands delay dialing for a 2 second interval. See your modem Operator's Guide and adjust the number of commas you use accordingly.

In the Automatic mode, the LineShare Pro 103 will answer a call, detect the tones and transfer the call to port P4.

In the Semi-Automatic mode, you or your answering machine will answer the call, then the LineShare Pro 103 will detect the tones and transfer the call to port P4.

For long distance remote access to port P4, instruct the caller to use the following dialing string in the modem's software:

ATDT 1 (phone number),,,#33,#33,#33,#33  
(for Automatic mode)

ATDT 1 (phone number),,,,,#33,#33,#33,#33  
(for Semi-Automatic mode)

**NOTE** In the Semi-Automatic mode, the commas entered before the #33 are set to your answering machine's 2 ring answer. Use 3 additional commas for each ring that your answering machine is set to answer above 2 rings.



---

---

## ComScan® Scanning / Intercom

The LineShare Pro 103 converts your fax machine into a full page, multi-document scanning system by using the built-in ComScan feature.

To scan a document through the LineShare Pro 103, connect a fax/modem or fax/modem card to port P4, and a fax machine to port P3. Once your equipment is connected properly, perform the following steps:

1. Set the fax/modem in "receive fax" on a 1 or 2 ring answer.
2. Insert the document to be scanned into the fax machine and take the fax machine's phone receiver off-hook and keep it off-hook for 10 seconds (or press **\*** **\*** **3** **3**).

3. When your fax/modem answers, press the fax machine's start button and return the phone receiver to its cradle.

After you complete these steps, your fax/modem will receive the document and store it as any received fax. You can then retrieve the document using your fax/modem's software to make changes or store it electronically. (There are many software packages on the market that allow you to modify a fax received by a fax/modem, see your local computer software dealer.)

Simply reverse the process to send a print job to your fax machine from your computer **\*** **\*** **2** **2**.

If the LineShare Pro 103 is installed with phones connected to all ports, this feature also allows an intercom path between ports. To make an internal call to another port, perform the following procedures:

1. Take a phone connected to the LineShare Pro 103 off-hook.
2. Press one of the following transfer codes from a tone phone:

**\*** **\*** **1** **1** for ports P1 and P2

**\*** **\*** **2** **2** for port P3

**\*** **\*** **3** **3** for port P4

3. Replace the phone receiver on-hook when finished.

---

---

## Remote Message Notification

Remote Message Notification (RMN) operates in either the Automatic mode or the Semi-Automatic mode.

The RMN feature allows the LineShare Pro 103 to automatically dial a telephone number when it receives a call to ports P1, P3, P4, or any combination of these ports. This feature is beneficial to notify users in the event of an important call or data transmission.

After an incoming call is complete (5 seconds), the LineShare Pro 103 calls the user-programmed RMN phone number. Once the LineShare Pro 103 dials the phone number, it produces a series of beeps (RMN Conditions) for 1 minute, which indicates the port(s) that received the call. You can set the RMN phone number and the RMN Conditions "on location" or remotely. (See RMN Phone Number and RMN Conditions.)

While the LineShare Pro 103 is on-line transmitting the beeps, it also allows entry of the Security Access Code to enter the remote programming mode.

If the LineShare Pro 103 receives a valid access code to transfer the call to ports P1 and P2, the call will be transferred and the caller can retrieve any messages.

If a valid code is not received after 1 minute, the LineShare Pro 103 will disconnect the call.

The factory setting for RMN is OFF. To change this feature, see "Programmable features of the LineShare Pro 103" for information.

# Programming the LineShare Pro 103

## Introduction

The LineShare Pro 103 has many features which can be used to customize its operation.

Many of these features have either feature settings or timing parameters associated directly with their operation. Therefore, read the following sections carefully to obtain the best results when programming the LineShare Pro 103.

## Entering and programming locally

Connect the LineShare Pro 103 as shown, using a tone phone (rotary/pulse dialing phones cannot program the LineShare Pro 103).

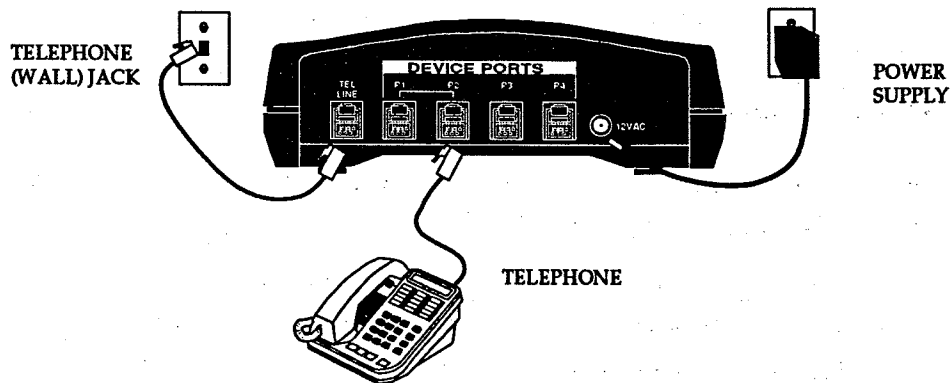

Programming changes can be performed from a tone phone connected to port P2 of an operational unit.

To enter the programming mode, take the phone off-hook, press **#** **\***

Once in programming, the LineShare Pro 103 allows 8 seconds between tone commands before exiting the programming mode without saving the changes. Therefore, it would be beneficial to write down all programming changes before entering the programming mode.

Once a complete tone command is entered, it must be followed by the **\*** key, which stores it into memory. After you enter the **\*** key, you can set as many features or feature settings as needed for your application. When all programming changes are complete, press **\*** **\*** to make changes permanent and exit programming.

The LineShare Pro 103 will not be able to process calls during programming sessions.

If during a programming session you receive a dial tone, the intercept operator message, or if programming was not successful, perform the following steps:

1. Disconnect power from the LineShare Pro 103.
2. Reconnect power to the LineShare Pro 103.
3. Approximately 1 second after restoring power to the LineShare Pro 103 take the phone in port P2 off-hook.
4. The LineShare Pro 103 will produce three beeps indicating entry into the programming mode.
5. Continue with programming changes as previously described.

---

---

## Entering and programming remotely

To program the LineShare Pro 103 remotely, the Security Access Code must be previously stored into memory.

From the remote location, dial the phone number of the line connected to the LineShare Pro 103. The call must be placed from a tone phone that has the **#** and **\*** keys. When the LineShare Pro 103 answers the call, and between ring signals, enter the **#** key and then the Security Access Code. The LineShare Pro 103 will beep 3 times indicating successful entry into the programming mode.

Continue with programming changes as previously described.

1. Remotely by tone phone by the end-user (Automatic mode only).
2. Remotely by the end-user after Remote Message Notification is activated.
3. Remotely by contacting Customer Service.

**NOTE** In the Semi-Automatic mode, the LineShare Pro 103 cannot be programmed remotely, unless the Remote Message Notification feature has been activated. The user can enter programming during the call placed when the LineShare Pro 103 activates Remote Message Notification.

---

---

## Remote Message Notification programming

To program the LineShare Pro 103 remotely, in this application, the LineShare Pro 103 can be in either the Automatic mode, or the Semi-Automatic mode, and the Security Access Code previously stored into memory.

When the LineShare Pro 103 meets the conditions required to activate the Remote Message Notification (RMN) feature (described later in this guide), it will dial the pre-programmed phone number and remain on line for 1 minute. While the LineShare Pro 103 is on line, it produces beep tones indicating which conditions were met to activate RMN (see RMN Conditions on page 34).

Between the beep tones, the user can enter the Security Access Code to enter the programming mode. After the Security Access Code is correctly entered, the LineShare Pro 103 will beep 3 times indicating successful entry into the programming mode.

Continue with programming changes as previously described.

After programming changes are complete, press **\*** **\*** to exit programming. The LineShare Pro 103 will produce a short ring to ports P1 and P2 then reset for the next call.

---

---

## Technical Support programming

The LineShare Pro 103 can also be programmed by Technical Support at no charge by calling:

**(412) 746-5500**

# Programmable features of the LineShare Pro 103

FEATURES	DEFAULT SETTING	OPTIONS	
		OFF	ON
<b>0</b> Extension Detection	OFF	<b>0 0</b>	<b>1 0</b>
<b>1</b> Answer Any Port	ON	<b>0 1</b>	<b>1 1</b>
<b>2</b> Automatic Port P1 Transfer	OFF	<b>0 2</b>	<b>1 2</b>
<b>3</b> Automatic No Answer Transfer	ON	<b>0 3</b>	<b>1 3</b>
<b>4</b> Outbound Voice Exclusion	OFF	<b>0 4</b>	<b>1 4</b>
<b>5</b> Automatic Ring Reduction	ON	<b>0 5</b>	<b>1 5</b>
<b>6</b> Automatic Ring Reduction Reset	OFF	<b>0 6</b>	<b>1 6</b>
<b>7</b> Caller ID	OFF	<b>0 7</b>	<b>1 7</b>
<b>8</b> Remote Message Notification	OFF	<b>0 8</b>	<b>1 8</b>
<b>9</b> Pound Key Required	ON	<b>0 9</b>	<b>1 9</b>
<b>1 0</b> Pulse Dial Transfer	ON	<b>0 1 0</b>	<b>1 1 0</b>
<b>1 1</b> Distinctive Ring Service Detection	OFF	<b>0 1 1</b>	<b>1 1 1</b>
<b>1 2</b> Single Tone Detection	ON	<b>0 1 2</b>	<b>1 1 2</b>
<b>1 3</b> Fax CNG (Calling) Tone Detection	ON	<b>0 1 3</b>	<b>1 1 3</b>
<b>1 4</b> Modem (Calling) Tone Detection	ON	<b>0 1 4</b>	<b>1 1 4</b>
<b>1 5</b> Reverse Modem Tone Detection	OFF	<b>0 1 5</b>	<b>1 1 5</b>
<b>1 7</b> ComScan Scanning / Intercom	OFF	<b>0 1 7</b>	<b>1 1 7</b>
<b>1 8</b> Automatic Port Transfer Selection	P3	<b>0 1 8</b>	<b>1 1 8</b>
<b>2 0</b> Unlimited Port Transfer	OFF	<b>0 2 0</b>	<b>1 2 0</b>

# Programmable feature settings of the LineShare Pro 103

FEATURE	DEFAULT SETTING	OPTIONS
<b>2 1</b> Operating Mode	210	<b>2 1 0</b> Automatic mode <b>2 1 1</b> Semi-Automatic mode
<b>3 0</b> Rings to Answer Call	1	<b>1</b> to <b>9 9</b>
<b>3 1</b> Rings to Ports P1 and P2	6	<b>1</b> to <b>9 9</b>
<b>3 2</b> Rings to Port P3	6	<b>1</b> to <b>9 9</b>
<b>3 3</b> Rings to Port P4	6	<b>1</b> to <b>9 9</b>
<b>4 0</b> Remote Security Access Code	NONE	<b>0</b> to <b>9 9 9 9</b>
<b>4 1</b> Ports P1 and P2 Transfer Code	11	<b>0</b> to <b>9 9 9 9</b>
<b>4 2</b> Port P3 Transfer Code	22	<b>0</b> to <b>9 9 9 9</b>
<b>4 3</b> Port P4 Transfer Code	33	<b>0</b> to <b>9 9 9 9</b>
<b>5 0</b> DRS Assignment	123	<b>0</b> to <b>3</b> for each port
<b>5 2</b> Phantom Ring Style	1	<b>0</b> to <b>4</b>
<b>6 0</b> Port Tone Assignment	016	<b>0</b> to <b>7</b> for each port
<b>6 1</b> RMN Conditions	1	<b>1</b> to <b>3</b>
<b>6 2</b> RMN Phone Number	NONE	up to 16 digits
<b>7 0</b> Single Tone Detection Timer	10	<b>4</b> to <b>9 9</b> seconds
<b>7 1</b> Ring Reduction Reset Timer	10	<b>1</b> to <b>6 0</b> minutes
<b>7 2</b> Port P1 Transfer Timer	30	<b>0</b> to <b>9 9</b> seconds
<b>7 3</b> Unlimited Port Transfer Timer	10	<b>1</b> to <b>4 0</b> seconds
<b>7 4</b> Scanning Timer	10	<b>5</b> to <b>2 0</b> seconds
<b>9 9 9</b> Reset to Factory Settings	999	<b>9 9 9</b>

---

---

## Extension Detection

Extension Detection operates in the Automatic mode. The Semi-Automatic mode already allows for the use of extension phones as part of its normal operation.

With Extension Detection turned OFF, the LineShare Pro 103 will only allow phones connected directly to ports P1 and P2 to answer a call. Extension phones will only be able to listen to the LineShare Pro 103 process the call as previously described.

If Extension Detection is turned ON, the LineShare Pro 103 will answer incoming calls on the first ring (Rings to Answer Call), and all extension phones ring one time. If the LineShare Pro 103 does not detect an identifying tone or tone transfer codes, it will ring ports P1 and P2 up to 6 times (Rings to Ports P1 and P2). For proper operation, answer any extension phone after the 2nd ring (with Extension Detection ON). If the call goes unanswered after 6 rings, the call is transferred to port P3, and the phones lose the ability to control the call.

If an extension has trouble accessing the line, press the **\*** to access the line. After the **\*** key is pressed, the LineShare Pro 103 will discontinue its call processing and allow the extension phone to access the line.

The factory setting for Extension Detection is OFF.

To turn this feature ON.

1. Take the phone in port P2 off-hook
2. Press **# \* 1 0 \*** (three beeps) **\***
3. Hang up the phone

To turn this feature OFF.

1. Take the phone in port P2 off-hook
2. Press **# \* 0 0 \*** (three beeps) **\***
3. Hang up the phone

---

---

## Answer Any Port

The Answer Any Port feature operates in either the Automatic mode or the Semi-Automatic mode.

When a call comes in, the Answer Any Port feature allows any port that is not ringing to answer the call. Once the call is answered, the LineShare Pro 103 listens for tone access codes to transfer the call to another port.

Conditions which allow the Answer Any Port feature to operate:      Conditions which restrict the Answer Any Port feature :

1. Any time between ring signals to ports P1 and P2
2. After a No Answer Transfer occurs
3. When Distinctive Ring Service Detection is activated

1. Automatic Port P1 Transfer
2. Single frequency tone transfer
3. Tone Access code transfer

(In the Semi-Automatic mode, Single Tone Detection will be activated when a device answers a call.)

The factory setting for the Answer Any Port feature is ON.

To turn this feature OFF

1. Take the phone in port P2 off-hook
2. Press **# \* 0 1 \*** (three beeps) **\***
3. Hang up the phone

To turn this feature ON

1. Take the phone in port P2 off-hook
2. Press **# \* 1 1 \*** (three beeps) **\***
3. Hang up the phone

---

---

## Automatic Port P1 Transfer

The Automatic Port P1 Transfer operates in either the Automatic mode or the Semi-Automatic mode.

This feature is designed to work in conjunction with an answering machine to transfer calls that do not produce identifying tones to the appropriate port.

If the answering machine answers a call and is on line for less than 30 seconds (Port P1 Transfer Timer) the LineShare Pro 103 will transfer the call to port P3 (Automatic Port Transfer Selection). If the call is on line for more than 30 seconds, the LineShare Pro 103 will simply reset for the next call when the answering machine disconnects.

If the Automatic Port P1 Transfer feature is turned OFF, the LineShare Pro 103 will reset each time the answering machine disconnects from a call. No transfer to port P3 will occur when the answering machine disconnects from a call.

The factory setting for Automatic Port P1 Transfer feature is OFF.

To turn this feature ON.

1. Take the phone in port P2 off-hook
2. Press **# \* 1 2 \*** (three beeps) **\***
3. Hang up the phone

To turn this feature OFF.

1. Take the phone in port P2 off-hook
2. Press **# \* 0 2 \*** (three beeps) **\***
3. Hang up the phone

---

---

## Automatic No Answer Transfer

The Automatic No Answer Transfer operates in either the Automatic mode or the Semi-Automatic mode.

This feature is designed to transfer calls that do not produce identifying tones to the appropriate port.

The LineShare Pro 103 will ring ports P1 and P2 6 times (Rings to Ports P1 and P2). If the call remains unanswered after 6 rings, the LineShare Pro 103 will transfer the call to port P3 (Automatic Port Transfer Selection).

If the LineShare Pro 103 transfers an unanswered call to port P3, it will automatically reduce the number of rings to the telephones connected to ports P1 and P2 to 2 rings (Automatic Ring Reduction) to ensure optimum connect time.

The LineShare Pro 103 will reset the ring count to 6 rings (Ring Reduction Reset) after 10 minutes (Ring Reduction Reset Timer) of inactivity on port P3. You can also manually reset the LineShare Pro 103 to 6 rings by performing any of the following steps:

- Lift the receiver of any phone device on the line connected to the LineShare Pro 103 and hang it up.
- Answer a call from any phone before the call is transferred to port P3.
- Place an outbound call from any phone on the line connected to the LineShare Pro 103.

If the Automatic No Answer Transfer feature is turned OFF, the LineShare Pro 103 will operate as follows:

Semi-Automatic mode

The call will continue to ring as long as the caller stays on line without transferring.

Automatic mode

The call will ring 6 times to ports P1 and P2 without transferring, then reset for the next call. The next incoming call will be processed with Ring Reduction activated as well as associated features and feature settings.

The factory setting for Automatic No Answer Transfer feature is ON.

To turn this feature OFF.

1. Take the phone in port P2 off-hook
2. Press **# \* 0 3 \*** (three beeps) **\***
3. Hang up the phone

To turn this feature ON.

1. Take the phone in port P2 off-hook
2. Press **# \* 1 3 \*** (three beeps) **\***
3. Hang up the phone

---

---

## Outbound Voice Exclusion

Outbound Voice Exclusion operates in either the Automatic mode or the Semi-Automatic mode.

This feature allows the LineShare Pro 103 to detect when an extension phone not connected to ports P1 and P2 goes off-hook to place a call. Once the extension phone is on-line, any device connected to the LineShare Pro 103 cannot access the phone line. The device simply receives a busy signal until the extension phone has disconnected from the call.

**NOTE** Phones or data devices connected directly to the LineShare Pro 103, do not require this feature, as the LineShare Pro 103 maintains exclusion between ports.

If Outbound Voice Exclusion is turned OFF, any call from an extension phone can be interrupted from one device connected to another port of the LineShare Pro 103.

The factory setting for Outbound Voice Exclusion is OFF.

To turn this feature ON.

1. Take the phone in port P2 off-hook
2. Press **# \* 1 4 \*** (three beeps) **\***
3. Hang up the phone

To turn this feature OFF.

1. Take the phone in port P2 off-hook
2. Press **# \* 0 4 \*** (three beeps) **\***
3. Hang up the phone

---

---

## Automatic Ring Reduction

Automatic Ring Reduction operates in either the Automatic mode or the Semi-Automatic mode.

This feature is designed to activate when Automatic No Answer Transfer sends an unanswered call to port P3. After this transfer occurs, the Automatic Ring Reduction is activated and allows only 2 rings to ports P1 and P2 for future calls.

The LineShare Pro 103 will reset the ring count to 6 rings (Ring Reduction Reset) after 10 minutes (Ring Reduction Reset Timer) of inactivity on port P3.

If Automatic Ring Reduction is turned OFF, the LineShare Pro 103 will continue to allow 6 rings (Rings Available to Ports P1 and P2) to ports P1 and P2 on every call. (Turning this feature OFF may limit some fax machine's ability to connect to your fax machine due to timing parameters.)

The factory setting for Automatic Ring Reduction is ON.

To turn this feature OFF.

1. Take the phone in port P2 off-hook
2. Press **# \* 0 5 \*** (three beeps) **\***
3. Hang up the phone

To turn this feature ON.

1. Take the phone in port P2 off-hook
2. Press **# \* 1 5 \*** (three beeps) **\***
3. Hang up the phone



---

---

## Automatic Ring Reduction Reset

Automatic Ring Reduction Reset operates in either the Automatic mode or the Semi-Automatic mode.

This feature is designed to reset the LineShare Pro 103 to allow 6 rings (Rings to Ports P1 and P2) to ports P1 and P2 after the Automatic Ring Reduction reduced the ring count to 2 rings.

The Automatic Ring Reduction Reset will reset the ring count to 6 rings after 10 minutes (Ring Reduction Reset Timer) of inactivity on port P3 (Automatic Port Transfer Selection).

If Automatic Ring Reduction Reset is turned OFF, the LineShare Pro 103 will continue to allow 2 rings to ports P1 and P2 on every call until it is manually reset (as previously described).

The factory setting for Automatic Ring Reduction Reset is OFF.

To turn this feature ON.

1. Take the phone in port P2 off-hook
2. Press **# \* 1 6 \*** (three beeps) **\***
3. Hang up the phone

To turn this feature OFF.

1. Take the phone in port P2 off-hook
2. Press **# \* 0 6 \*** (three beeps) **\***
3. Hang up the phone

---

---

## Caller ID

The Caller ID feature operates in either the Automatic mode or the Semi-Automatic mode. (Caller ID requires service activation from the phone company.)

This feature allows Caller ID devices to be connected directly to ports P1 or P2 of the LineShare Pro 103.

Operation in the Automatic mode and Semi-Automatic mode vary as follows:

### Automatic mode

When the LineShare Pro 103 is in the Automatic mode, the Rings to Answer feature must be set to a 2 ring answer to allow Caller ID information to pass directly to ports P1 and P2. When a call comes in, the first 2 rings are passed directly to ports P1 and P2. Between the first and second rings, the Caller ID will display its information. The LineShare Pro 103 then answers the call and continues as described in Automatic mode operation. (NOTE: Single Tone Detection is not activated until the LineShare Pro 103 answers the call after 2 rings.)

### Semi-Automatic mode

In this mode, Caller ID is always ON. When a call comes in, all rings are passed directly to ports P1 and P2. Between the first and second rings, the Caller ID will display its information, and the call continues as described in Semi-Automatic mode operation.

The factory setting for Caller ID is OFF.

To turn this feature ON

1. Take the phone in port P2 off-hook
2. Press **# \* 1 7 \*** (three beeps) **\***
3. Hang up the phone

To turn this feature OFF

1. Take the phone in port P2 off-hook
2. Press **# \* 0 7 \*** (three beeps) **\***
3. Hang up the phone

---

---

## Remote Message Notification (RMN)

Remote Message Notification operates in either the Automatic mode or the Semi-Automatic mode.

The RMN feature allows the LineShare Pro 103 to automatically dial a telephone number when it receives a call to ports P1, P3, P4, or any combination of these ports. This feature is beneficial to notify users in the event of an important call or data transmission.

After an incoming call is complete (5 seconds), the LineShare Pro 103 calls the user-programmed RMN phone number. Once the LineShare Pro 103 dials the phone number, it produces a series of beeps (RMN Conditions) for 1 minute, which indicates the port or ports that received the call. You can set the RMN phone number and the RMN conditions "on location" or remotely. (See RMN Phone Number and RMN Conditions.)

While the LineShare Pro 103 is on-line transmitting the beeps, it also allows entry of the Security Access Code to enter the remote programming mode.

If the LineShare Pro 103 receives a valid access code to transfer the call to ports P1 and P2, the call will be transferred and the caller can retrieve any messages from the answering machine.

If a valid code is not received after 1 minute, the LineShare Pro 103 will disconnect the call.

The factory setting for RMN is OFF.

To turn this feature ON

1. Take the phone in port P2 off-hook
2. Press **# \* 1 8 \*** (three beeps) **\***
3. Hang up the phone

To turn this feature OFF

1. Take the phone in port P2 off-hook
2. Press **# \* 0 8 \*** (three beeps) **\***
3. Hang up the phone

---

---

## Pound Key Transfer Required

The Pound Key Transfer Required feature operates in either the Automatic mode or the Semi-Automatic mode.

This feature allows the LineShare Pro 103 to determine whether or not the **#** key is required on an inbound call to transfer to a port, or for entering the remote programming mode using the Security Access Code.

If this feature is turned OFF, you or the caller can transfer a call to any port on the LineShare Pro 103 by entering the access code required for the port without entering the **#** key. However, if an incorrect access code is entered, the caller can re-enter the access code with the **#** key included to complete a transfer.

With this feature turned ON, if an incorrect access code is entered, you or the caller can simply re-enter the access code (with the **#** key) to transfer the call.

The factory setting for the Pound Key Transfer Required feature is ON.

To turn this feature OFF

1. Take the phone in port P2 off-hook
2. Press **# \* 0 9 \*** (three beeps) **\***
3. Hang up the phone

To turn this feature ON

1. Take the phone in port P2 off-hook
2. Press **# \* 1 9 \*** (three beeps) **\***
3. Hang up the phone

---

---

## Pulse Dial Transfer

Pulse Dial Transfer operates in either the Automatic mode or the Semi-Automatic mode.

This feature allows rotary/pulse dial phones to transfer calls to another port on the LineShare Pro 103. The Pulse Dial Transfer codes are **5** for port P2, **3** for port P3, **4** for port P4.

Operation in the Automatic mode and Semi-Automatic mode vary as follows:

### Automatic mode

Pulse dial transfer is allowed after a call has been answered (and/or transferred) from any device connected directly to any port of the LineShare Pro 103.

On an outbound call, pulse dial transfers are allowed 20 seconds after dialing the last digit of the phone number.

### Semi-Automatic mode

Pulse dial transfer is allowed after a call has been answered (and/or transferred) from any extension phone, as well as phones connected to any port of the LineShare Pro 103.

On an outbound call, pulse dial transfers are allowed 20 seconds after dialing the last digit of the phone number.

Pulse dial transfers cannot be initiated by the calling party. Calls can only be pulse transferred from phones connected to the LineShare Pro 103 (depending on operating mode).

The factory setting for Pulse Dial Transfer is ON.

#### To turn this feature OFF

1. Take the phone in port P2 off-hook
2. Press **# \* 0 1 0 \*** (three beeps) **\***
3. Hang up the phone

#### To turn this feature ON

1. Take the phone in port P2 off-hook
2. Press **# \* 1 1 0 \*** (three beeps) **\***
3. Hang up the phone

---

---

## Distinctive Ring Service Detection

Distinctive Ring Service (DRS) Detection operates in either the Automatic mode or the Semi-Automatic mode.

This feature allows the LineShare Pro 103 to recognize the various ring signals from the phone company when DRS is activated. It works with DRS Assignment to automatically transfer calls to any port on the LineShare Pro 103 without identifying tones or transfer codes.

See Distinctive Ring service on pages 10-11 for a detailed description of operating procedures.

The factory setting for Distinctive Ring Service Detection is OFF.

#### To turn this feature ON

1. Take the phone in port P2 off-hook
2. Press **# \* 1 1 1 \*** (three beeps) **\***
3. Hang up the phone

#### To turn this feature OFF

1. Take the phone in port P2 off-hook
2. Press **# \* 0 1 1 \*** (three beeps) **\***
3. Hang up the phone

---

---

## Single Tone Detection

Single Tone Detection operates in either the Automatic mode or the Semi-Automatic mode.

This feature allows the LineShare Pro 103 to detect single frequency tones (for the duration of the Single Tone Detection Timer) from various data devices. It recognizes the following tones:

- 1100Hz Fax CNG tone (if turned ON)
- 2225Hz reverse modem tone (if turned ON)
- a 1300Hz modem calling tone (if turned ON)

Operation in the Automatic mode and Semi-Automatic mode vary as follows:

### Automatic mode

Once the LineShare Pro 103 answers a call, it will listen for and transfer calls when a single frequency tone is detected. The Single Tone Detection Timer begins when the LineShare Pro 103 answers the call. After the timer expires, the LineShare Pro 103 will only transfer using the tone and pulse access codes.

### Semi-Automatic mode

The Single Tone Detection Timer begins when the call is answered. Once the call is answered, the LineShare Pro 103 will listen for and transfer calls when a single frequency tone is detected. After the timer expires, transfers will require tone and pulse access codes.

The factory setting for Single Tone Detection is ON.

To turn this feature OFF

1. Take the phone in port P2 off-hook
2. Press **# \* 0 1 2 \*** (three beeps) **\***
3. Hang up the phone

To turn this feature ON

1. Take the phone in port P2 off-hook
2. Press **# \* 1 1 2 \*** (three beeps) **\***
3. Hang up the phone

**NOTE**

This feature supersedes the following features: Fax CNG Detection, Modem Calling Tone Detection, Reverse Modem Detection. If Single Tone Detection is turned OFF, these features will not operate even if they are programmed ON.

---

---

## Fax CNG (Calling) Tone Detection

Fax CNG Tone Detection operates in either the Automatic mode or the Semi-Automatic mode.

This feature allows the LineShare Pro 103 to detect an 1100 Hz Fax CNG tone.

Operation in the Automatic mode and Semi-Automatic mode varies as follows:

### Automatic mode

Once the LineShare Pro 103 answers a call, it will listen for and transfer calls when a CNG tone is detected.

### Semi-Automatic mode

Once a call is answered, the LineShare Pro 103 will listen for and transfer calls when a CNG tone is detected.

The factory setting for Fax CNG Tone Detection is ON.

To turn this feature OFF

1. Take the phone in port P2 off-hook
2. Press **# \* 0 1 3 \*** (three beeps) **\***
3. Hang up the phone

To turn this feature ON

1. Take the phone in port P2 off-hook
2. Press **# \* 1 1 3 \*** (three beeps) **\***
3. Hang up the phone

---

---

## Modem Calling Tone Detection

Modem Calling Tone Detection operates in either the Automatic mode or the Semi-Automatic mode.

This feature allows the LineShare Pro 103 to detect a 1300 Hz modem calling tone.

Operation in the Automatic mode and Semi-Automatic mode varies as follows:

### Automatic mode

Once the LineShare Pro 103 answers a call, it will listen for and transfer calls when a modem calling tone is detected.

### Semi-Automatic mode

Once a call is answered, the LineShare Pro 103 will listen for and transfer calls when a modem calling tone is detected.

The factory setting for Modem Calling Tone Detection is ON.

#### To turn this feature OFF

1. Take the phone in port P2 off-hook
2. Press **# \* 0 1 4 \*** (three beeps) **\***
3. Hang up the phone

#### To turn this feature ON

1. Take the phone in port P2 off-hook
2. Press **# \* 1 1 4 \*** (three beeps) **\***
3. Hang up the phone

---

---

## Reverse Modem Tone Detection

Reverse Modem Tone Detection operates in either the Automatic mode or the Semi-Automatic mode.

This feature allows the LineShare Pro 103 to detect a 2225 Hz reverse modem tone.

Operation in the Automatic mode and Semi-Automatic mode varies as follows:

### Automatic mode

Once the LineShare Pro 103 answers a call, it will listen for and transfer calls when a reverse modem tone is detected.

### Semi-Automatic mode

Once a call is answered, the LineShare Pro 103 will listen for and transfer calls when a reverse modem tone is detected.

The factory setting for Reverse Modem Tone Detection is OFF.

#### To turn this feature ON

1. Take the phone in port P2 off-hook
2. Press **# \* 1 1 5 \*** (three beeps) **\***
3. Hang up the phone

#### To turn this feature OFF

1. Take the phone in port P2 off-hook
2. Press **# \* 0 1 5 \*** (three beeps) **\***
3. Hang up the phone

## ComScan® Scanning / Intercom

The ComScan Scanning / Intercom feature operates in either the Automatic mode or the Semi-Automatic mode.

This feature converts your fax machine into a full page, multi-document scanning system. It allows automatic port to port transfer between ports P3 and port P4.

To scan a document through the LineShare Pro 103, a fax/modem or fax/modem card must be connected to port P4, and a fax machine connected to port P3. Once the equipment is connected properly, perform the following steps:

1. Set the fax/modem in "receive fax" on a 1 or 2 ring answer.
2. Insert the document to be scanned into the fax machine and take the fax machine's phone receiver off-hook and keep it off-hook for 10 seconds (Scanning Timer).
3. When the fax/modem answers, press the fax machine's start button and return the phone receiver to its cradle.

After these steps are complete, the fax/modem will receive the document and store it as any received fax. The document can be retrieved using the fax/modem's software to make changes or store it electronically. (There are many software packages on the market that allow modification of a fax received by a fax/modem, see a local computer software dealer.)

Simply reverse the process to send a print job to your fax machine from your computer.

The LineShare Pro 103 can manually transfer calls between ports for document scanning by the following tone commands (even if this feature is turned OFF):

1. \* \* 1 1 to transfer to ports P1 and P2
3. \* \* 2 2 to transfer to port P3
3. \* \* 3 3 to transfer to port P4

**NOTE** Port to port exclusion is not provided during a scanning transfer.

The factory setting for ComScan Scanning / Intercom is OFF.

To turn this feature ON

1. Take the phone in port P2 off-hook
2. Press # \* 1 1 7 \* (three beeps) \*
3. Hang up the phone

To turn this feature OFF

1. Take the phone in port P2 off-hook
2. Press # \* 0 1 7 \* (three beeps) \*
3. Hang up the phone

---

---

## Automatic Port Transfer Selection

Automatic Port Transfer Selection operates in either the Automatic mode or the Semi-Automatic mode.

This feature designates where the call is routed by Automatic Port P1 Transfer and Automatic No Answer Transfer features. The call may be routed to either port P3 or P4.

The factory setting for Automatic Port Transfer Selection is port P3.

To select transfer to port P4

1. Take the phone in port P2 off-hook
2. Press **# \* 1 1 8 \*** (three beeps) **\***
3. Hang up the phone

To select transfer to port P3

1. Take the phone in port P2 off-hook
2. Press **# \* 0 1 8 \*** (three beeps) **\***
3. Hang up the phone

---

---

## Unlimited Port Transfer

Unlimited Port Transfer Selection operates in either the Automatic mode or the Semi-Automatic mode.

This feature allows the LineShare Pro 103 to transfer from port to port on a single telephone call. With this feature turned ON, the LineShare Pro 103 will hold the telephone line after a device disconnects from a call. When the line is open, the LineShare Pro 103 beeps 2 times indicating to the caller that it is ready to transfer the call to another port. The caller can then enter another port transfer code to reach another device. Any transfer must occur before the Unlimited Port Transfer Timer expires (see "Programmable Feature Settings"); if this timer expires, the LineShare Pro 103 beeps 1 time then disconnects from the call.

The factory setting for Unlimited Port Transfer Selection is OFF.

To turn this feature ON

1. Take the phone in port P2 off-hook
2. Press **# \* 1 2 0 \*** (three beeps) **\***
3. Hang up the phone

To turn this feature OFF

1. Take the phone in port P2 off-hook
2. Press **# \* 0 2 0 \*** (three beeps) **\***
3. Hang up the phone

---

---

## Operating mode

The Operating mode can be set in either the Automatic mode or the Semi-Automatic mode as previously described.

The factory setting is for operation in the Automatic mode **# \* 2 1 0 \* \***

To set the LineShare Pro 103 for Semi-Automatic mode, perform the following steps:

1. Take the phone in port P2 off-hook
2. Press **# \* 2 1 1 \*** (three beeps) **\***
3. Hang up the phone

---

---

## Rings to Answer Call

Rings to Answer Call operates in the Automatic mode only.

This feature determines how many times an incoming phone call rings before it is answered by the LineShare Pro 103. The factory setting is 1 ring, to permit the LineShare Pro 103 to answer and transfer calls as quickly as possible. Under normal circumstances, it is not necessary to change this setting.

However, if using the phone company's Caller ID service, set this feature to answer the call on 2 rings.

This feature has a range of 1 to 99 rings to answer a call. If this ring count is set higher than 1 ring and a call is answered from an extension phone before the LineShare Pro 103 answers, the single tone and rotary/pulse transfer is deactivated. The tone transfer access codes still function only if preceded by the **#** key.

The factory setting for the Rings to Answer Call is 1 ring. To change this feature, perform the following steps:

1. Take the phone in port P2 off-hook
2. Press **#** **\*** **3** **0**   **\*** (three beeps) **\***  
(blank keys represent new Rings to Answer Call)
3. Hang up the phone

---

---

## Rings to Ports P1 and P2

Rings to Ports P1 and P2 operate in either the Automatic mode or the Semi-Automatic mode.

This feature determines the number of rings that the LineShare Pro 103 provides to ports P1 and P2. Operation in the Automatic mode and the Semi-Automatic mode is only slightly different.

### Automatic mode

When a call comes in, the LineShare Pro 103 answers the call. If transfer tones are not present, the LineShare Pro 103 rings 6 times (default setting) to ports P1 and P2 while waiting for the call to be answered. After this ring count expires, the LineShare Pro 103 transfers the call to port P3 (Automatic No Answer Transfer).

### Semi-Automatic mode

When a call comes in, all 6 rings (default setting) are passed directly to ports P1 and P2 while the LineShare Pro 103 waits for the call to be answered. After this ring count expires, the LineShare Pro 103 transfers the call to port P3 (Automatic No Answer Transfer).

This feature has a range of 1-99 rings available to ports P1 and P2.

The factory setting for the Rings to Ports P1 and P2 is 6 rings. To change this feature, perform the following steps:

1. Take the phone in port P2 off-hook
2. Press **#** **\*** **3** **1**   **\*** (three beeps) **\***  
(blank keys represent new Rings to Ports P1 and P2)
3. Hang up the phone



---

---

## Rings to Port P3

Rings to Port P3 operates in either the Automatic mode or the Semi-Automatic mode.

This feature determines the number of rings that the LineShare Pro 103 provides to port P3. Operation in the Automatic mode and the Semi-Automatic mode is only slightly different.

### Automatic mode

Any time a call is transferred to port P3, this feature allows 6 rings for the fax machine to answer, then disconnects from the call.

### Semi-Automatic mode

When a call comes in, the LineShare Pro 103 will ring ports P1 and P2 6 times. If the call remains unanswered, the LineShare Pro 103 transfers the call to port P3 (Automatic No Answer Transfer). The call will ring until the fax machine answers or the caller hangs up.

If the call is answered on port P1 or P2 and then transferred to port P3, this feature allows 6 rings for the fax machine to answer, then disconnects from the call.

This feature has a range of 1-99 rings available to port P3.

The factory setting for the Rings to port P3 is 6 rings. To change this feature, perform the following steps:

1. Take the phone in port P2 off-hook
2. Press **#** **\*** **3** **2** **□** **□** **\*** (three beeps) **\***  
(blank keys represent new Rings to Port P3)
3. Hang up the phone

---

---

## Rings to Port P4

Rings to Port P4 operates in either the Automatic mode or the Semi-Automatic mode.

This feature determines the number of rings that the LineShare Pro 103 provides to port P4. Operation in the Automatic mode and the Semi-Automatic mode is only slightly different.

### Automatic mode

Any time a call is transferred to port P4, this feature allows 6 rings for the computer modem to answer, then disconnects from the call.

### Semi-Automatic mode

When a call comes in, the LineShare Pro 103 rings ports P1 and P2 6 times. If the call remains unanswered, the LineShare Pro 103 transfers the call to port P4 (Automatic No Answer Transfer, if port P4 is selected for this transfer). The call will ring until the computer modem answers or the caller hangs up.

If the call is answered on port P1 or P2 and then transferred to port P4, this feature allows 6 rings for the computer modem to answer, then disconnects from the call.

This feature has a range of 1-99 rings available to port P4.

The factory setting for the Rings to Port P4 is 6 rings. To change this feature, perform the following steps:

1. Take the phone in port P2 off-hook
2. Press **#** **\*** **3** **3** **□** **□** **\*** (three beeps) **\***  
(blank keys represent new Rings to Port P4)
3. Hang up the phone

---

---

## Remote Security Access Code

The Remote Security Access Code operates in the Automatic mode (or if RMN is activated in the Semi-Automatic mode).

This feature designates the tone access code that will be required to program the LineShare Pro 103 from a remote location.

Once entered, the LineShare Pro 103 stores it in non-volatile memory until removed through programming.

The Remote Security Access Code can be any numeric 1-4 digits not including the **#** key. See Pound Key Transfer Required for use with the Remote Security Access Code. Do not use a transfer code for a port on the LineShare Pro 103, or **0 0 0 0**.

The factory setting for the Remote Security Access Code is unprogrammed for your protection. It must be entered before you can access the remote programming mode. To enter an access code, perform the following steps:

1. Take the phone in port P2 off-hook
2. Press **# \* 4 0** (three beeps) **\***  
(blank keys represent new Remote Security Access Code)
3. Hang up the phone

---

---

## Ports P1 and P2 Transfer Code

The Ports P1 and P2 Transfer Code operates in either the Automatic mode or the Semi-Automatic mode.

This feature designates the tone access code that will be required to transfer a call from either port P3 or P4, extension phones, or to ports P1 and P2.

The Ports P1 and P2 Transfer Code can be any numeric 1-4 digits not including the **#** key. See Pound Key Transfer Required for use with the Ports P1 and P2 Transfer Code. Do not use a code that is a transfer code for a port on the LineShare Pro 103.

The factory setting for the Ports P1 and P2 Transfer Code is **1 1**. To enter a new access code, perform the following steps:

1. Take the phone in port P2 off-hook
  2. Press **# \* 4 1** (three beeps) **\***  
(blank keys represent new Ports P1 and P2 Transfer Code)
  3. Hang up the phone
- A code of **0 0 0 0** will disable tone access.

---

---

## Port P3 Transfer Code

The Port P3 Transfer Code operates in either the Automatic mode or the Semi-Automatic mode.

This feature designates the tone access code required to transfer a call from either port P1 or P2, extension phones, or port P4 to port P3.

The Port P3 Transfer Code can be any numeric 1-4 digits not including the **#** key. See Pound Key Transfer Required for use with the Port P3 Transfer Code. Do not use a code that is a transfer code for a port on the LineShare Pro 103.

The factory setting for the Port P3 Transfer Code is **2 2**. To enter a new access code, perform the following steps:

1. Take the phone in port P2 off-hook
  2. Press **# \* 4 2** (three beeps) **\***  
(blank keys represent new Port P3 Transfer Code)
  3. Hang up the phone
- A code of **0 0 0 0** will disable tone access.

---

## Port P4 Transfer Code

The Port P4 Transfer Code operates in either the Automatic mode or the Semi-Automatic mode.

This feature designates the tone access code required to transfer a call from either port P1 or P2, extension phones, or port P3 to port P4.

The Port P4 Transfer Code can be any numeric 1-4 digits not including the **#** key. See Pound Key Transfer Required for use with the Port P4 Transfer Code. Do not enter a code that is a transfer code for a port on the LineShare Pro 103.

The factory setting for the Port P4 Transfer Code is **3 3**. To enter a new access code, perform the following steps:

1. Take the phone in port P2 off-hook
2. Press **# \* 4 3**     **\*** (three beeps) **\***  
(blank keys represent new Port P4 Transfer Code)

3. Hang up the phone

A code of **0 0 0 0** will disable tone access.

---

## DRS Assignment

The DRS Assignment operates in either the Automatic mode or the Semi-Automatic mode.

This feature designates where the LineShare Pro 103 will transfer a call using the Distinctive Ring service. It has the ability to recognize three different ring signals:

- 0** no ring assigned
- 1** standard ring
- 2** two-burst ring
- 3** three-burst ring

After entering the programming mode, and this feature setting, the LineShare Pro 103 looks for a 3 digit entry to set the port designations for the individual rings. The first digit represents ports P1 and P2, the second digit represents port P3, and the third digit represents port P4. The LineShare Pro 103 cannot be set to transfer a ring signal to more than one port.

The factory setting is **# \* 5 0 1 2 3 \*** which transfers a one burst ring to ports P1 and P2, a two burst ring to port P3, and a three burst ring to port P4.

To change this feature, perform the following steps:

1. Take the phone in port P2 off-hook
2. Press **# \* 5 0**    **\*** (three beeps) **\***  
(blank keys represent new DRS Assignment)
3. Hang up the phone

**NOTE** If a ring burst is not assigned, the LineShare Pro 103 will not respond to the incoming call designated to that phone number.

Each ring burst can be assigned to 1 port; if you attempt to assign a ring burst to more than 1 port, the LineShare Pro 103 will give an error tone.

---

---

## Phantom Ring Style

The Phantom Ring Style operates in either the Automatic mode or the Semi-Automatic mode.

In the Automatic mode, the LineShare Pro 103 answers the call and produces a "phantom" ring signal, making the switching process transparent to the caller.

In the Semi-Automatic mode, it will produce this ring signal any time a call is transferred to a port from an identifying tone, an access code, or from the Automatic Port P1 Transfer feature.

(The LineShare Pro 103 has 4 different ring signals to choose from, allowing you to select a style similar to your local phone company's ring signal.)

The following ring types are available:

	Ringback selection	Break time	Ring time	Single tone/ Dual tones
	0 None	N/A	N/A	N/A
	1 USA	4 sec	2 sec	Dual
	2 Special #1	4 sec	2 sec	Single
	3 Special #2	5 sec	1 sec	Dual
	4 Special #3	5 sec	1 sec	Single

The factory setting is # \* 5 2 1 \* which is the common US ring signal.

To change this feature, perform the following steps:

1. Take the phone in port P2 off-hook
2. Press # \* 5 2 [ ] \* (three beeps) \*  
(the blank key represents new Phantom Ring Style)
3. Hang up the phone

---

---

## Port Tone Assignment

Port Tone Assignment operates in either the Automatic mode or the Semi-Automatic mode.

This feature designates where the LineShare Pro 103 will transfer a call that produces the following identifying tones:

- 1100Hz CNG tone (if turned ON)
- 2225Hz reverse modem tone (if turned ON)
- 1300Hz modem calling tone (if turned ON)

The tones can be set to transfer automatically (depending on operating mode) to any port on the LineShare Pro 103.

After entering the programming mode, and this feature setting, the LineShare Pro 103 looks for a 3 digit entry to set the port designations for receiving tone transfers. The first digit represents ports P1 and P2, the second digit represents port P3, and the third digit represents port P4. The LineShare Pro 103 cannot be set to transfer any tone to more than one port.

Following are the digits that represent the tones for setting port designations:

0	No tone assigned
1	1100Hz CNG
2	2225Hz reverse modem
3	2225Hz reverse modem & 1100Hz CNG
4	1300Hz modem calling tone
5	1300Hz modem calling tone & 1100Hz CNG
6	1300Hz modem calling tone & 2225Hz reverse modem
7	1300Hz modem calling tone & 2225Hz reverse modem & 1100Hz CNG

The factory setting for Port Tone Assignment is **# \* 6 0 0 1 6 \* \***. To change this feature, perform the following steps:

1. Take the phone in port P2 off-hook
2. Press **# \* 6 0**    **\*** (three beeps) **\***  
(blank keys represent selection of tones)
3. Hang up the phone

---

---

## RMN Conditions

The RMN Conditions operate in either the Automatic mode or the Semi-Automatic mode.

This feature allows you to define which port or ports being accessed will invoke RMN. The LineShare Pro 103 will invoke RMN under the following conditions:

- Port P1 message
- Port P3 message
- Ports P1 and P3 message
- Port P4 message
- Ports P1 and P4 message
- Ports P3 and P4 message
- Ports P1, P3 and P4 message

For the LineShare Pro 103 to invoke RMN after a port P1 message is received, port P1 must be on-line longer than the value of the **Automatic Port P1 Transfer Timer**. If port P1 is not on-line longer than the **Automatic Port P1 Transfer Timer**, the LineShare Pro 103 will not invoke RMN, or will exclude port P1 as part of the RMN information (depending on the setting of **RMN Conditions**).

If port P3 or P4 are accessed for *any* amount of time, and the LineShare Pro 103 is set up to invoke RMN when port P3 or P4 receives a call, the LineShare Pro 103 will dial the RMN phone number.

After the LineShare Pro 103 dials the **RMN phone number**, it begins transmitting a series of beeps indicating the RMN condition that was met. The following list indicates the RMN condition and the series of indicating tones produced by the LineShare Pro 103:

- Port P1 message = 1 beep
- Port P3 message = 2 beeps
- Ports P1 and P3 message = 3 beeps
- Port P4 message = 4 beeps
- Ports P1 and P4 message = 5 beeps
- Ports P3 and P4 message = 6 beeps
- Ports P1, P3 and P4 message = 7 beeps

The factory setting for the RMN Conditions is **# \* 6 1 1 \***. This allows the LineShare Pro 103 to activate RMN if port P1 is accessed under the previously stated conditions. **1** represents port P1, **2** represents port P3, **3** represents port P4. When programming the LineShare Pro 103, any digit can be entered, or all three digits. Program the LineShare Pro 103 as follows:

1. Take the phone in port P2 off-hook
2. Press **# \* 6 1**    **\*** (three beeps) **\***  
(blank keys represent new RMN Conditions)
3. Hang up the phone

## RMN Phone Number

The RMN Phone Number operates in either the Automatic mode or the Semi-Automatic mode.

This feature designates the phone number that is dialed by the LineShare Pro 103 when RMN is activated and all RMN Conditions have been met. It can dial any telephone or cellular number up to 16 digits long (pagers excluded). It will remain in memory until you remove it.

There is no factory setting for this feature. To enter an RMN Phone Number, perform the following steps:

1. Take the phone in port P2 off-hook
2. Press **# \* 6 2** (up to 16 digits) **\*** (three beeps) **\***  
(entry following the **6 2** represent new RMN Phone Number)
3. Hang up the phone

## Single Tone Detection Timer

The Single Tone Detection Timer operates in either the Automatic mode or the Semi-Automatic mode.

This feature designates the timing parameters for operation of the Single Tone Detection feature.

When Single Tone Detection is activated, but this timer expires on a call, the LineShare Pro 103 will not transfer calls producing identifying tones.

This feature has a range of 4-30 seconds.

The factory setting for the Single Tone Detection Timer is 10 seconds. To change this feature, perform the following steps:

1. Take the phone in port P2 off-hook
2. Press **# \* 7 0**   **\*** (three beeps) **\***  
(blank keys represent new Single Tone Detection Timer setting)
3. Hang up the phone

---

---

## Ring Reduction Reset Timer

The Ring Reduction Reset Timer operates in either the Automatic mode or the Semi-Automatic mode.

This feature designates the timing parameters for operation of Automatic Ring Reduction and Automatic Ring Reduction Reset. It is activated when the Automatic No Answer Transfer transfers a call to port P3, and the Automatic Ring Reduction reduces the Rings Available to Ports P1 and P2 from 6 rings to 2 rings.

When this feature is activated, the LineShare Pro 103 monitors ports P3 and P4 for activity. If there is no activity for 10 minutes, the Automatic Ring Reduction Reset will return the previous Rings Available to ports P1 and P2 count.

This feature has a range of 1-60 minutes. The Rings to Ports P1 and P2 can be reset manually as previously described.

The factory setting for the Ring Reduction Reset Timer is 10 minutes. To change this feature, perform the following steps:

1. Take the phone in port P2 off-hook
2. Press **# \* 7 1**   **\*** (three beeps) **\***  
(blank keys represent new Ring Reduction Reset Timer setting)
3. Hang up the phone

---

---

## Port P1 Transfer Timer

The Port P1 Transfer Timer operates in either the Automatic mode or the Semi-Automatic mode.

This feature designates the timing parameters for operation of the Automatic Port P1 Transfer. It is designed to facilitate the timing parameters of fax machines that do not produce CNG tones.

When using the Automatic Port P1 Transfer feature, set this feature to 10 seconds longer than the outgoing announcement message. If the outgoing announcement message is 10 seconds, set this timer to 20 seconds. This will allow adequate time for non-CNG faxes to reach the fax machine, yet allow callers to leave messages on the answering machine without transferring to port P3 when the call is complete (if their message is longer than 10 seconds).

This feature has a range of 0-99 seconds. If 0 or 00 is entered, the Automatic Port P1 Transfer will always transfer calls to port P3 regardless of time on the line.

The factory setting for the Port P1 Transfer Timer is 30 seconds. To change this feature, perform the following steps:

1. Take the phone in port P2 off-hook
2. Press **# \* 7 2**   **\*** (three beeps) **\***  
(blank keys represent new Port P1 Transfer Timer setting)
3. Hang up the phone

---

---

## Unlimited Port Transfer Timer

The Unlimited Port Transfer Timer operates in either the Automatic mode or the Semi-Automatic mode.

This feature designates the timing parameters for operation of the Unlimited Port Transfer. During this time period, if the LineShare Pro 103 receives routing tones, it will transfer the call to the designated port. If it does not receive routing tones before the time expires, the LineShare Pro 103 will beep 1 time and release the call.

This feature has a range of 1-40 seconds. The factory setting for the Unlimited Port Transfer Timer is 10 seconds. To change this feature, perform the following steps:

1. Take the phone in port P2 off-hook
2. Press **# \* 7 3**   **\*** (three beeps) **\***  
(blank keys represent new Unlimited Port Transfer Timer setting)
3. Hang up the phone

---

---

## Scanning Timer

The Scanning Timer operates in either the Automatic mode or the Semi-Automatic mode.

This feature designates the timing parameters for operation of the ComScan Scanning feature .

When a device in port P3 or P4 goes off-hook, this timer is activated. If the LineShare Pro 103 does not detect dialing during the next 10 seconds (Scanning Timer), it transfers the call to the other port (port P3 or P4).

This feature has a range of 5-20 seconds.

The factory setting for the Scanning Timer is 10 seconds. To change this feature, perform the following steps:

1. Take the phone in port P2 off-hook
2. Press **# \* 7 4 [ ] [ ] \*** (three beeps) **\***  
(blank keys represent new Scanning Timer setting)
3. Hang up the phone

---

---

## Reset to Factory Settings

To reset all features and feature settings to their original factory settings, perform the following steps:

1. Take the phone in port P2 off-hook
2. Press **# \* 9 9 9 \*** (three beeps) **\***
3. Hang up the phone