

1 Quick Setup

This section briefly describes how to install your KVM extender system. Unless you are an experienced user, we recommend that you follow the full procedures described in the rest of this manual..

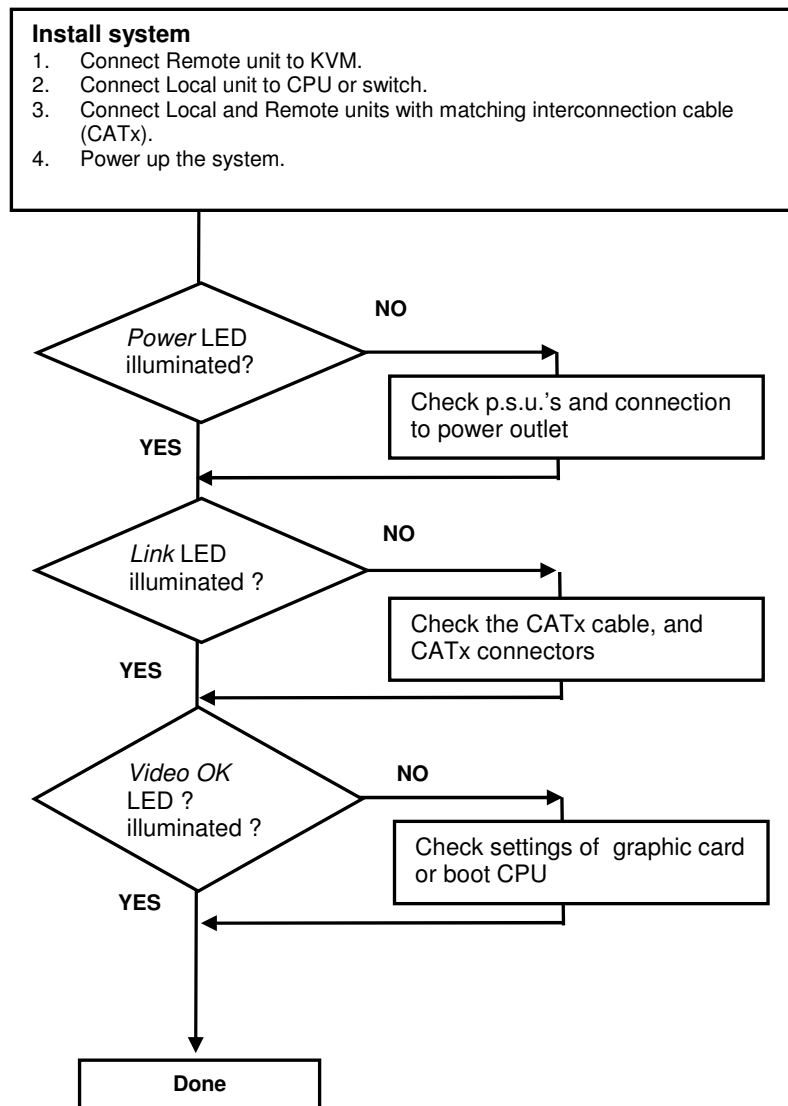

2 Installation

For first-time users, we recommend that you carry out a test placement, confined to a single room, before commencing full installation. This will allow you to identify and solve any cabling problems, and experiment with the KVM extender system more conveniently.

2.1 Package Contents

You should receive the following items in your extender package (all types):

- DVI-D KVM Extender KVM-Extender- pair (Local Unit + Remote Unit)
- 2x 5V DC universal power supply for the DVI-D KVM Extender - Extender
- 2x German type power cord
- Quick Install Guide
- CDROM with user manual
- KVM CPU cable set (1.8m) consisting of 1.8m USB-A/B cable and 1.8m DVI-D M/M cable

ACS4201A (additionally):

- 1.8m DVI-D M/M cable

If anything is missing, please contact Technical Support

2.2 System Setup

To install your DVI-D KVM Extender – Extender system:

1. Switch off all devices.
2. Connect your keyboard, monitor(s) and mouse to the Remote unit.
3. Using the supplied CPU KVM cable(s), connect the USB and monitor(s) connectors on the computer (or KVM switch).
4. Connect the interconnect cable to the INTERCONNECT socket(s)
5. Connect the 5V power supply to power the unit.



Only use the power supply originally supplied with this equipment or a manufacturer-approved replacement.

6. For a dual access system, connect the USB (keyboard, mouse) and monitor for the Local console to the appropriate ports on the Local unit. The ports may also be used to feed into a KVM switch. For dual access, you may feed your local monitor into the DVI-D output connector at the local unit. To attach a second keyboard/mouse, please use additional USB port(s) at your CPU or use a USB Hub inbetween CPU and local unit's USB connector.
7. Power up the system.

2.3 Interconnection Cable Requirements

To connect the Local and Remote units you will need:

- **DVI, USB-Keyboard, USB-Mouse:** Connect the supplied KVM CPU cable set to your CPU (KVM.- Switch, etc.). Please ensure that the connection is tension-free! Devices ACS4001A + ACS4201A
- **DVI:** Connect the supplied DVI CPU cable set to your CPU (KVM.- Switch, etc.). Please ensure that the connection is tension-free! Devices ACS4201A
- **CATx Cable:** Recommended cable: S/UTP (Cat5) according EIA/TIA 56A, TSB 36 or Digital STP 17-03170. Four pairs AWG 24. connection according EIA/TIA 568A (10BaseT). Use of cables from a higher category (Cat5e, Cat6, Cat7) is possible.

The use of unshielded CATx Cable is possible, because of the higher electromagnetic noise/sensitivity the device class may not be reached.

The use of flexible Cables (Patch cable) Type AWG26/8 is possible. Because of the higher loss of the stranded cables, the maximum distance is reduced to app. half the value of solid cables.



A point to point connection is required. Having one or more patch panels in the line is possible and allowed. Not allowed is a connection from the CATx link interface (RJ45) to any other products, especially telecommunications or network equipment.

3 Device view (depending on device type)

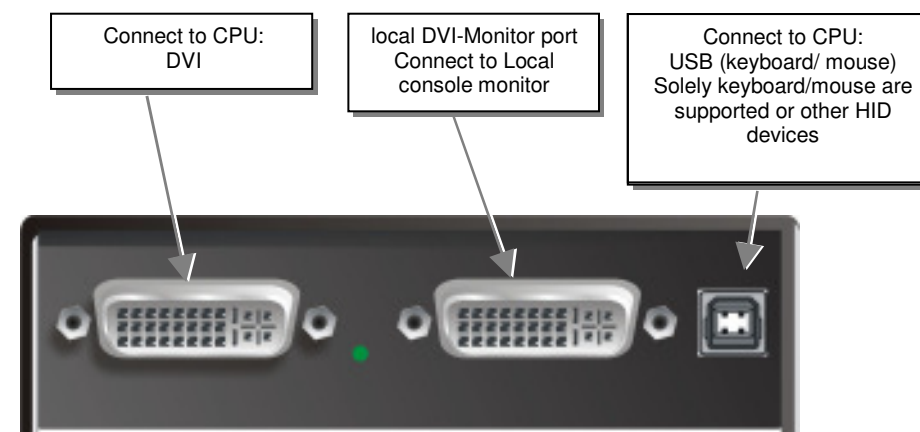

DVI-D KVM Extender KVM-Extender Type ACS4001A Local Unit

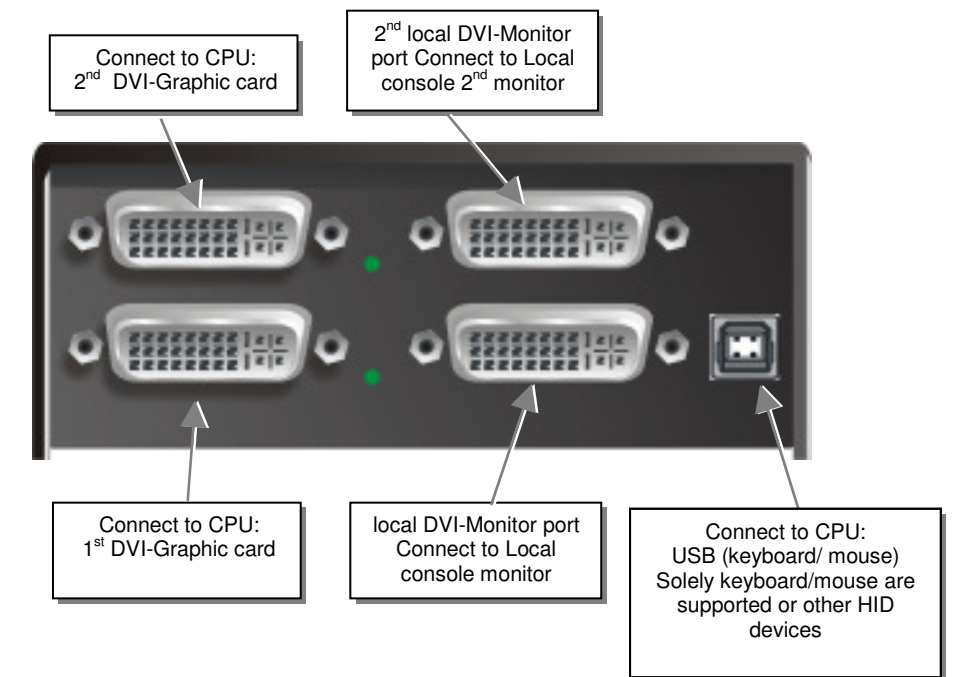

DVI-D KVM Extender KVM-Extender Type ACS4201A Local Unit

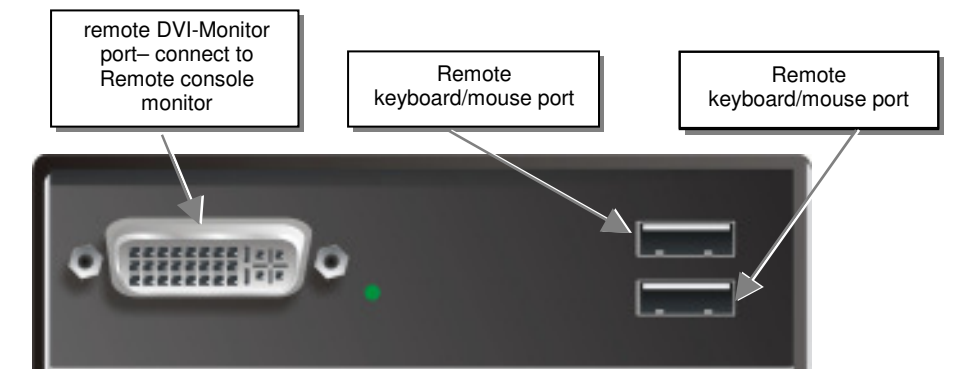

DVI-D KVM Extender KVM-Extender Type ACS4001A Remote Unit

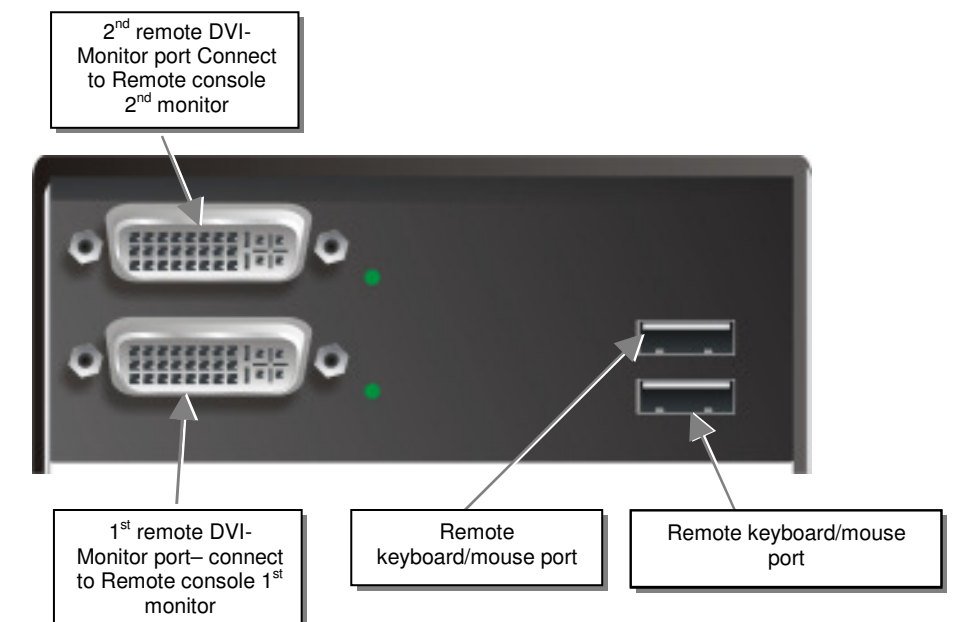

DVI-D KVM Extender KVM-Extender Type ACS4201A Remote Unit

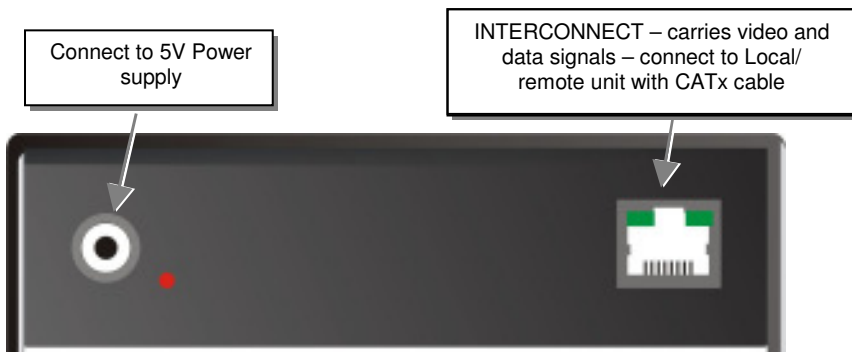

DVI-D KVM Extender KVM-Extender Type ACS4001A Local/ Remote Unit

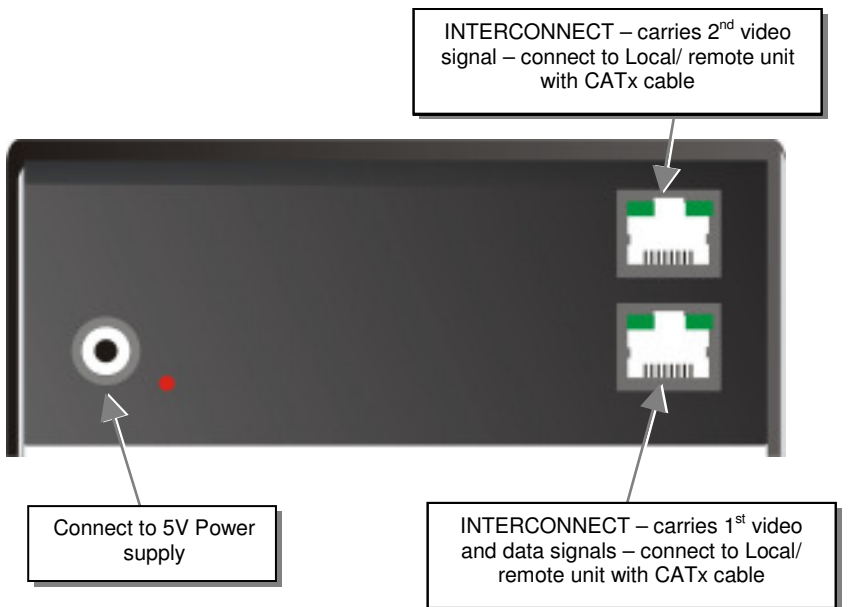

DVI-D KVM Extender KVM-Extender Type ACS4201A Local/ Remote Unit

3.1 Diagnostic LEDs

Each DVI-D KVM Extender KVM-Extender is fitted with four indicator LEDs: *Power*, *Video OK*, *Data Error*, *Link Status*. The *Power* LEDs are next to the Power socket.

The location of the LEDs is shown below:

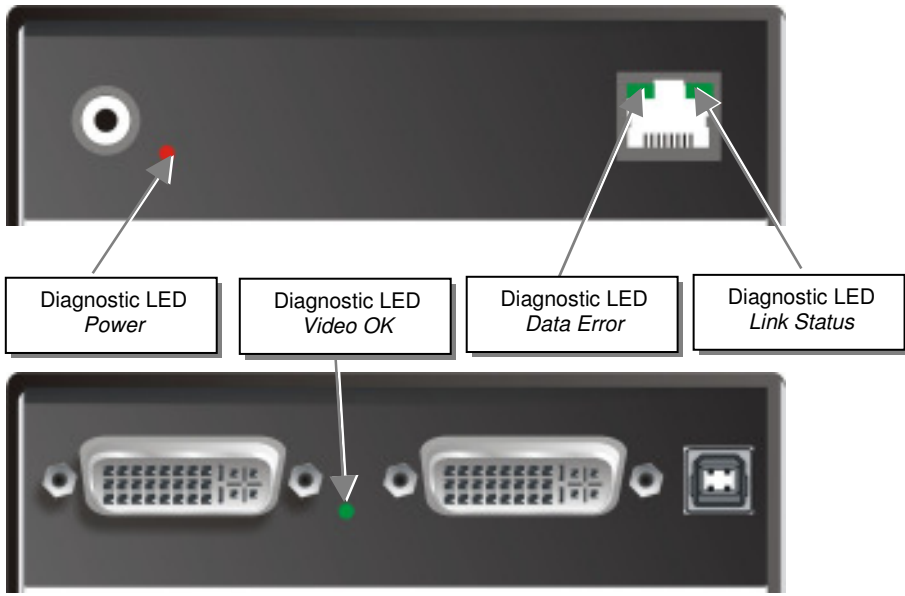

Diagnostic - LEDs at DVI-D KVM Extender

LED	Appearance	Diagnostics
Power LED (Red LED)	Off On	Device not ready Device ready
Video Okay (Green LED)	Off On	No or invalid video signal detected Device ready
Link Status (Green LED)	blinking On	No CAT5 connection Device ready
Data Error (Green LED)	Off blinking / On	Device ready Errors through data transmission over CAT5 Cable (Cable too long, too high attenuation or too much EMI interferences)

4 Troubleshooting

There isn't a picture.

Check the power supply connection at the Local unit. Is the *Power* (Red LED) at the Local unit illuminated? If not, the internal power-supply may be damaged or there may be an internal error.

Check the power supply connection at the remote unit. Is the *Power* (Red LED) at the Remote unit illuminated? If not, the internal power-supply may be damaged or there may be an internal error.

Check that the Interconnection cable is connected at the Local Unit and the Remote Unit. Is the *Link Status* LED illuminated? If not, there may be a problem with the Interconnection cable:

Are there Errors through data transmission over CAT5 Cable (Cable too long, too high attenuation or too much EMI interferences)? Is the *Data Error* LED illuminated or blinking? If yes, check cable length and environment.

Video Okay LED is dark: CPU does not provide a video signal – Check settings of the graphic card. Try out, connecting a monitor to the local output, to see, whether ther is a signal or not.

USB-Keybaord/USB-Mouse

Your USB-keyboard/USB-mouse does not work

Although we tried to design the devices as transparent as possible, we can't ensure that all devices are running. Please check in the manual the list of the tested devices.

USB-HID devices

Your USB-HID device does not work

Although our interface supports HID devices, we can't ensure that every connected device is running. In case of a malfunction please contact our technical support.

Other USB-devices

Your USB- device does not work

You have connected a non-HID device. Only HID devices are supported. All other devices are dismissed



DVI-D-CatX-KVM-Extender Single and DualHead

ACS4001A
ACS4201A

(Quick Setup)

<http://www.blackbox.com>

Black Box Network Services -
The world's largest network services company
We are, with 25 years of experience, the world leader in network infrastructure services.