

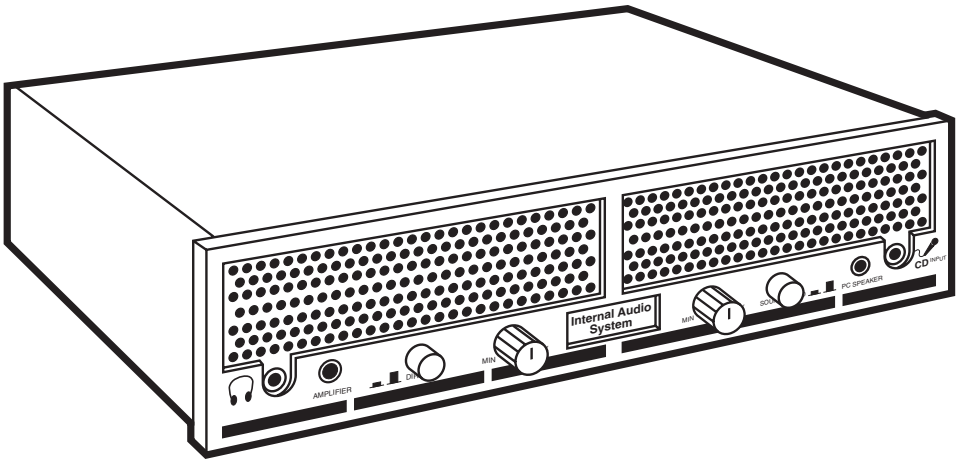

Internal Audio System



**CUSTOMER
SUPPORT
INFORMATION**

Order toll-free in the U.S. 24 hours, 7 A.M. Monday to midnight Friday: **877-877-BBOX**
FREE technical support, 24 hours a day, 7 days a week: Call **724-746-5500** or fax **724-746-0746**
Mail order: **Black Box Corporation**, 1000 Park Drive, Lawrence, PA 15055-1018
Web site: www.blackbox.com • E-mail: info@blackbox.com

FEDERAL COMMUNICATIONS COMMISSION AND INDUSTRY CANADA RADIO FREQUENCY INTERFERENCE STATEMENT

Class B Digital Device. This equipment has been tested and found to comply with the limits for a Class B computing device pursuant to Part 15 of the FCC Rules. These limits are designed to provide reasonable protection against harmful interference in a residential installation. However, there is no guarantee that interference will not occur in a particular installation. This equipment generates, uses, and can radiate radio frequency energy, and, if not installed and used in accordance with the instructions, may cause harmful interference to radio communications. If this equipment does cause harmful interference to radio or telephone reception, which can be determined by turning the equipment off and on, the user is encouraged to try to correct the interference by one of the following measures:

- Reorient or relocate the receiving antenna.
- Increase the separation between the equipment and receiver.
- Connect the equipment into an outlet on a circuit different from that to which the receiver is connected.
- Consult an experienced radio/TV technician for help.

Caution:

Changes or modifications not expressly approved by the party responsible for compliance could void the user's authority to operate the equipment.

To meet FCC requirements, shielded cables and power cords are required to connect this device to a personal computer or other Class B certified device.

This digital apparatus does not exceed the Class B limits for radio noise emission from digital apparatus set out in the Radio Interference Regulation of Industry Canada.

Le présent appareil numérique n'émet pas de bruits radioélectriques dépassant les limites applicables aux appareils numériques de la classe B prescrites dans le Règlement sur le brouillage radioélectrique publié par Industrie Canada.

TRADEMARKS

Any other trademarks mentioned in this manual are acknowledged to be the property of the trademark owners.

1. Specifications

System Requirements — At least one available 5¼-inch standard disk bay

Speakers — 8-ohm stereo

Frequency Response — 250 Hz-20 KHz @ 83 dB with SPL

Magnetic Flux Density Leakage— <6 gauss (measured at enclosure)

Amplifiers — Built-in: -4W, 10W direct driven

Power — +12 VDC from the PC

Size — 1.7"H x 5.7"W x 7.9"D (4.3 x 14.5 x 20.1 cm)

Weight — 1.5 lb. (0.7 kg)

WARNING!

Permanent or temporary hearing loss or impairment may result from excessive amplification of the sound through the headphone jacks. Before wearing any headphones, please hold them away from your ears to prevent any injury from unexpected sound or static noise.

2. Introduction

2.1 Features

Your new Internal Audio System transforms any PC into a high-quality audio system. The Internal Audio System installs easily in any existing standard 5¼-inch disk bay. It's packed with many convenient features:

- Two powerful, high-quality amplified stereo speakers.
- Engineered to be 100% safe for use in close proximity with all magnetic devices.
- Compatible with all sound boards, CD-ROMs, CD digital audio players, and MPC systems.
- Replaces your original PC speaker, giving you better frequency response and volume control.
- Can be used with third-party sound boards to capture, display, and edit audio waveforms.
- Convenient front-panel access to headphone output and microphone or CD input jacks.
- Independent left/right volume controls.
- Direct Driven/Amplifier selection.
- PC Speaker/Sound Board selection.

2.2 Your Package Includes:

Unpack the Internal Audio System from its original shipping package and check the contents. The package includes:

- (1) Internal Audio System unit.
- (1) Metal Bracket with (2) colored right-angle stereo cables attached.
- (2) 6-inch right-angle stereo cables.
- PC-Speaker Mono Cable.
- (4) Screws to anchor the Internal Audio System to your PC.
- This User's Guide.

2.3 Before You Get Started

Be sure to read **Section 4, Installation**, before proceeding with the actual installation and operation of this unit.

For further information on proper operation, please read **Section 5 Operating Modes**. If you encounter problems while installing your Internal Audio System in an older computer chassis, or to address other questions you may have regarding installation, please call Black Box.

2.4 Calling Black Box

If the Internal Audio System malfunctions or the package arrives incomplete, *do not attempt to alter or repair the unit*. It contains no user-serviceable parts. Contact Black Box. Before you do, make a record of the history of the problem. Black Box will be able to provide more efficient and accurate assistance if you have a complete description, including:

- The nature and duration of the problem.
- When the problem occurs.
- The components involved in the problem.
- Any particular application that, when used, appears to create the problem or make it worse.

2.5 Shipping and Packaging the Unit

If you need to transport or ship your Internal Audio System:

- We recommend that you use the original packaging container.
- If you are returning the Internal Audio System, make sure you include this manual as well. Before you ship, contact Black Box to get a Return Materials Authorization (RMA) number.

2.6 Warnings

To avoid electrical shock, do not open the unit. Refer servicing to qualified technicians only.

Permanent or temporary hearing loss or impairment may result from excessive amplification of the sound through the earphone jacks. Before wearing any headphones, please hold them away from your ears to prevent any injury from unexpected sound or static noise.

3. Controls and Functions

This section describes the physical features, controls, and their functions for the Internal Audio System. See Figure 3.1 for the front-panel location of items 1 through 9. Figure 3.2 shows a back-panel view of the unit, and the location of items 10 through 13.

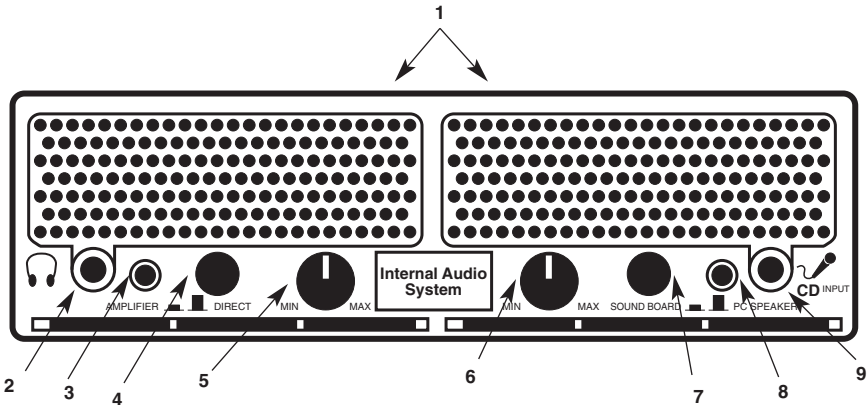

Figure 3.1. Front-Panel View Showing Controls and Connectors.

- 1) **Left and Right Audio Speakers** — Provide stereo sound at your PC.
- 2) **Stereo Headphone Output** — Allows you to listen to stereo output from your own headphones or earphones.
- 3) **Left LED** — This LED is frequency-modulated and flashes during audio output.
- 4) **Amplified/Direct-Driven Selection Switch (A)** — This switch allows you to amplify the audio input through the Internal Audio System's built-in amplifier, or be directly driven by an external amplifier.
- 5) **Left Volume Control** — Controls the audio output level to the left speaker.
- 6) **Right Volume Control** — Controls the audio output level to the right speaker.

- 7) **Sound Board/PC Speaker or Microphone Selection Switch (B)** — Lets you select the audio input source: either from a sound board or the PC speaker (back panel), or from a Microphone input (front panel).
- 8) **Right LED** — This LED is frequency-modulated and flashes during audio output.
- 9) **Microphone or CD Input** — This jack accepts a Microphone, CD-ROM, CD digital audio, or other sound source as input.

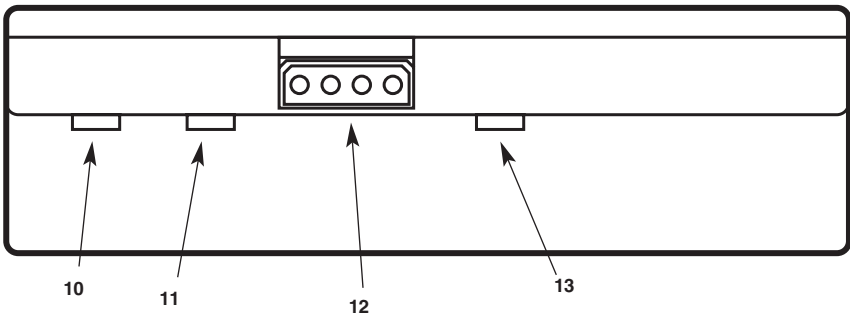

Figure 3.2. Back-Panel Connectors.

- 10) **Sound Board Stereo Input** — This input accepts audio that comes from your sound board and can be internally amplified by the Internal Audio System.
- 11) **PC Speaker Input (Mono)** — Use this input to divert audio output from your PC Speaker to the Internal Audio System.
- 12) **Power Input Connector** — This connector accepts your PC's standard internal power plug and provides the power source for the Internal Audio System.
- 13) **Microphone Stereo Output** — Use this output to pass signals (recordings) back to the input channel of your sound board for voice annotations.

4. Installation

There are just 10 simple steps to follow for a quick and easy installation of your Internal Audio System:

Step 1

Switch off power to the PC in which you're installing the Internal Audio System. Remove the CPU housing cover from your PC (follow instructions provided with your computer) and locate the open 5¼-inch disk bay.

Step 2

Slide the Internal Audio System unit into the 5¼-inch disk bay in your PC. You may have to apply slight, steady pressure to seat the unit completely in the disk bay.

Step 3 (Skip to Step 5 if your PC does not have a sound board).

Find a vacant slot opening in the back panel of your PC and remove the existing metal blanking panel (if any). Insert the Metal Bracket with the attached colored stereo cables, provided with the Internal Audio System. See Figure 4.1.

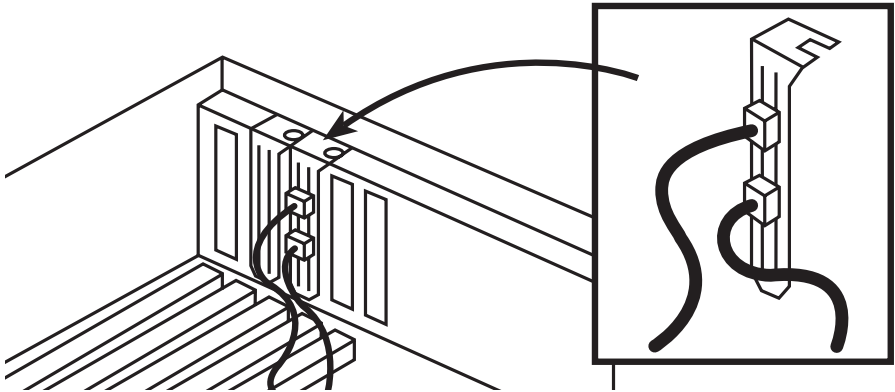

Figure 4.1. Interior View of PC Expansion Slot Compartment, Showing Installation of the Metal Bracket.

Step 4

Use the two 6-inch right-angle cables (provided) to externally connect the output jack on the sound board to the input jack on the Metal Bracket, and the output jack on the Metal Bracket to the input jack on the sound board. See Figure 4.2.

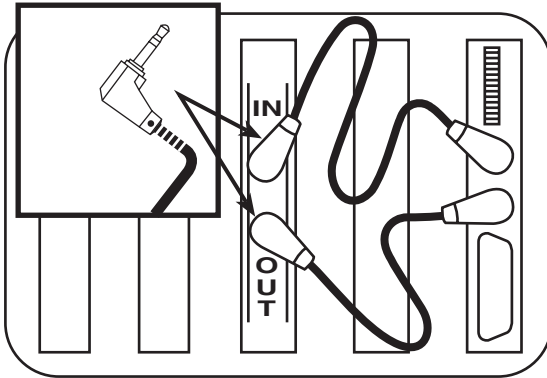

Figure 4.2. Connecting the Metal Bracket to a Preinstalled PC Sound Board (Back-Panel View).

Step 5

Find an unused internal power plug located inside your PC and plug this into the Power Input Connector on back of the Internal Audio System. See Figure 4.3.

Step 6

Plug the black cable from the Metal Bracket into the Microphone Stereo Output jack on back of the Internal Audio System. Plug the green Metal Bracket cable into the Sound Board Stereo Input jack. See Figure 4.3.

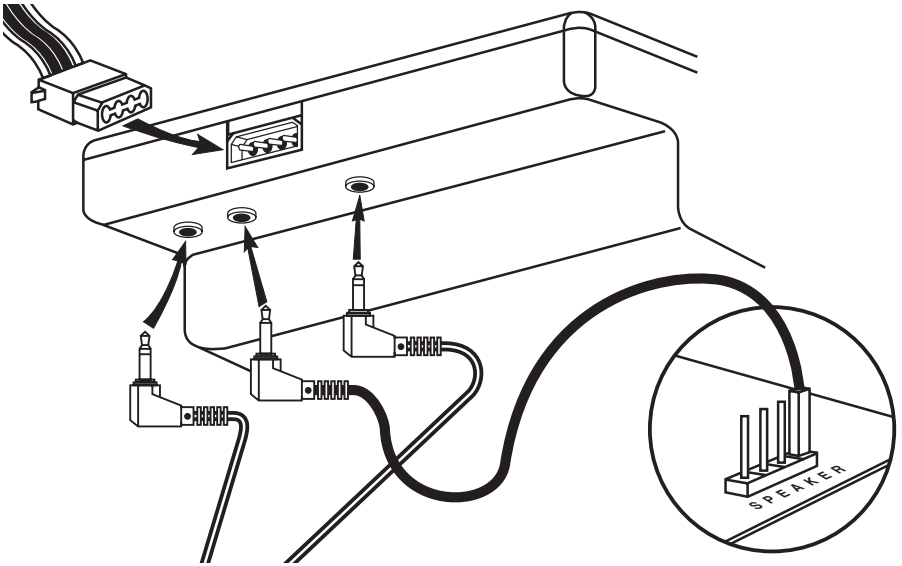

Figure 4.3. Connecting the Internal Audio System Unit.

Step 7

Plug one end of the Mono Cable (provided) into the PC Speaker Input (Mono) jack on back of the Internal Audio System unit. Plug the other end into either the right or left prong of the PC motherboard connector labeled SPEAKER. See Figure 4.3.

NOTE

You can verify whether you've attached to the correct **SPEAKER** prong by listening for an amplified beep after you switch on power to the computer (Step 9). If you do not hear the beep, repeat Step 7 but attach the Mono Cable motherboard connector to the opposite-end **SPEAKER** prong.

Step 8

Secure the Internal Audio System unit to your PC using the four screws provided with the package.

Step 9

Replace and resecure your PC's CPU housing cover. Then switch on power to the computer.

Step 10

Check the front-panel LEDs on the Internal Audio System to ensure that they're lit. If they aren't, remove the cover from your PC and confirm that all the Internal Audio System connections have been made and that the connectors are properly seated.

If the LEDs still don't light, call Black Box for technical support.

5. Operating Modes

The Internal Audio System is designed for maximum application flexibility with peripheral audio devices such as sound boards, CD-ROMs, CD digital audio players, headphones, and microphones.

You select the operating mode by setting the front-panel Selection Switches (A and B). There are four primary settings:

Switch A (In) — AMPLIFIED









Switch A (Out) — DIRECT

Switch B (In) — SOUND BOARD

Switch B (Out) — PC SPEAKER

By setting these switches in a variety of combinations, you can implement a number of input/output configurations. Table 5.1 shows the possible settings and the Internal Audio System's functions in that configuration.

Table 5.1. A and B Selection Switch Settings and Operating Modes.

Switch A	Switch B	Microphone/CD Input	Action	Use
		NONE	Allows non-amplified sound to be received at the back panel, if Metal Bracket is installed.	Receive audio from the sound board.
		Microphone, CD, or other sound source	External audio passes to the sound board via the back panel and is amplified through the front speakers.	Voice annotation using third-party sound boards.
		NONE	Audio is received from the PC motherboard and amplified through the front speakers.	Applications requiring better audio output than that provided by your PC's internal speaker.
		Microphone, CD, or other sound source	Source audio is received from the front CD/Microphone input and amplified through the speakers.	Easy front-panel access to an external sound source.

6. Troubleshooting

If you determine that your Internal Audio System is not working properly, there are several steps you can take to resolve the problem yourself.

Trouble	Cause	Solution
Distorted Sound.	<ul style="list-style-type: none"> — Volume up too high. — Bad or incorrect connections. 	<ul style="list-style-type: none"> — Reduce the volume. — Make sure that all connections are made, and that the connectors are properly seated.
Weak or no sound from either or both speakers.	<ul style="list-style-type: none"> — Input level from sound card or other external sound source is too low. — Connections are loose. — Switch A is set to DIRECT when input is driven by sound card. — Sound source is not present. 	<ul style="list-style-type: none"> — Increase the input level from sound card or other external source. — Tighten any loose connections. — Set Switch A to AMPLIFIED (In). — Check for presence of sound source.
Microphone recording is distorted.	<ul style="list-style-type: none"> — Switch B is not set to SOUND BOARD (In). 	<ul style="list-style-type: none"> — Set Switch B to SOUND BOARD (In).
LEDs aren't lit.	<ul style="list-style-type: none"> — Connection to the internal PC power source may not be secure. 	<ul style="list-style-type: none"> — Make sure the power-source connection is made and properly seated.

If these solutions do not resolve the problem, then contact Black Box for additional technical support. Remember, this unit contains no user-serviceable parts. *Do not attempt to alter or repair it yourself.*



© Copyright 1994. Black Box Corporation. All rights reserved.

1000 Park Drive • Lawrence, PA 15055-1018 • 724-746-5500 • Fax 724-746-0746