



© 2002. All rights reserved.
Black Box Corporation.

BLACK BOX[®]

NETWORK SERVICES

MULTITOOL CABLE TESTER

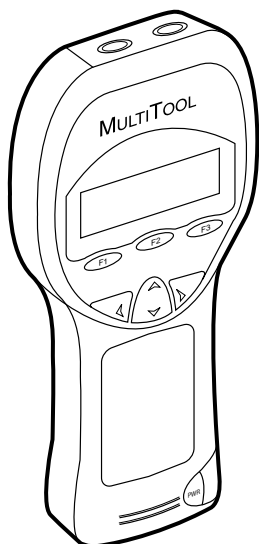

*Pinpointing shorts and opens is easy
with this versatile tool!*

Key Features

- ▶ **Identify locations of opens and shorts in seconds.**
- ▶ **Measure cable length in a box, on a spool, or in a wall.**
- ▶ **Transmit tone signals for tracing hidden cable runs.**
- ▶ **Measure voltage to identify live circuits.**
- ▶ **Includes an extensive library of cable types.**
- ▶ **Compatible with all common cables.**
- ▶ **Displays length in feet or meters.**

The MultiTool Cable Tester quickly finds faults in cables up to a distance of 2500 ft. (762 m). This versatile tool is a favorite with contractors, electricians, low-voltage installers, and with anyone installing or maintaining metallic cables.

Use the tester to find cables damaged during or after installation. The damaged section is often hidden behind walls, above ceilings, or buried underground. You can also use the tester to determine the length of cable remaining on a spool or in a box.

Here's how it works: Using Time-Domain Reflectometry (TDR), the Tester measures the distance from one end of the cable to a fault or measures the length of a cable, by transmitting

high-frequency pulses and examining their reflections along the cable. It determines how long a cable is based on the *time* that it takes the transmitted signal to be *reflected* back and how strong the signal is.

To operate the tester, simply select the appropriate cable type from the built-in library of over sixty cable types, then attach the test leads to two conductors of the cable. Press a button to display (on a single screen) the length of the cable and the distance to an open or short.

When multiple runs are being installed in the same area, the first run can be measured to accurately determine the total amount of cable required to complete the job. If you check cable inventory before starting a

job, you won't have to go out and buy more cable in the middle of a job.

The tester also works with standard tone probes for tracing cable. Suppose you have a large telecommunication closet with hundreds of cables in bundles. If you have a group of 20 or 30 cables coming out of a ceiling, it might be difficult to determine which one is coming out of an office next to the closet. The MultiTool Cable Tester can act as a tone generator (in conjunction with a tone probe, ordered separately) to "trace" or find the correct cable in the bundle. A tech at one end of the cable can induce a tone onto a cable (via the tester) and a tech at the other end can find that same cable by waving a probe near the cable bundle.



Simply pressing a button gives you all of this information.

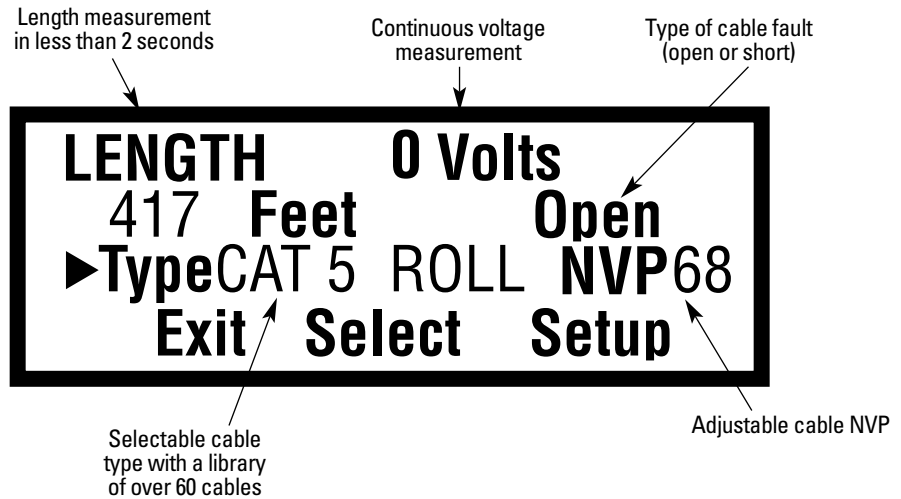

Specifications

Display: Graphical 122 x 32 pixels

Tracing Time: Frequencies: 575 Hz, 977 Hz, 1.0 kHz, 7.82 kHz; Patterns: Four

Length: Accuracy: $\pm 2\%$ plus ± 2 ft. (0.6 m) with correct NVP; Resolution: 1 ft. (0.3 m); Maximum: 2500 ft. (762 m)

Voltage (True RMS Responding): Range: Up to 250 V (AC or DC); Accuracy: $\pm 3\%$ plus 1 V

Temperature:

Operating: 32 to 122°F (0 to 50°C); Storage: 14 to 131°F (-10 to +55°C)

Power: (4) AA alkaline batteries

Size: 7"H x 3.2"W x 1.4"D (17.8 x 8.1 x 3.6 cm)

Weight: 8.7 oz. (247 g)

Why Buy From Black Box? Exceptional Value. Exceptional Tech Support. Period.

Recognize any of these situations?

- You wait more than 30 minutes to get through to a vendor's tech support.
- The so-called "tech" can't help you or gives you the wrong answer.
- You don't have a purchase order number and the tech refuses to help you.
- It's 9 p. m. and you need help, but your vendor's tech support line is closed.

According to a survey by Data Communications magazine, 90% of network managers surveyed say that getting the technical support they need is extremely important when choosing a

vendor. But even though network managers pay anywhere from 10 to 20% of their overall purchase price for a basic service and support contract, the technical support and service they receive falls far short of their expectations—and certainly isn't worth what they paid.

At Black Box, we guarantee the best value and the best support. You can even consult our Technical Support Experts before you buy if you need help selecting just the right component for your application.

Don't waste time and money—call Black Box today.

What the Package Includes

- (1) MultiTool Cable Tester
- (1) Red test lead with alligator clip
- (1) Black test lead with alligator clip
- (4) Alkaline batteries
- (1) Carrying case
- (1) Users' manual

Ordering Information

ITEM	CODE
MultiTool Cable Tester.....	TS570A

